

TETHER KILL SWITCH

The BikeMaster Tether Kill Switch is a UNIVERSAL design, not specific to any particular vehicle.

P/N 266181: NORMALLY OPEN (MAGNETO IGNITION)

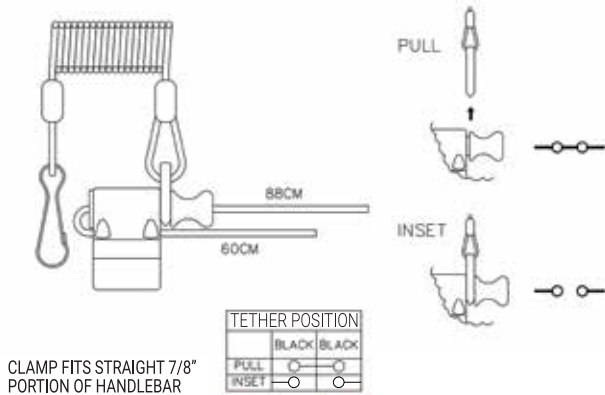

Normally-open kill switches are used to create an open circuit when the lanyard clip is installed. When the lanyard clip is removed, the circuit completes a ground, stalling the machine.

Install one of the two black wire leads to a clean ground using an existing frame-mounted bolt. The remaining black lead will be spliced into the wire between the stator and ignition coil, DO NOT CONNECT KILL SWITCH TO HIGH OUTPUT SPARK PLUG WIRE. If there is any question to which wire should be used, please consult a factory service manual.

P/N 266182: NORMALLY CLOSED (BATTERY IGNITION)

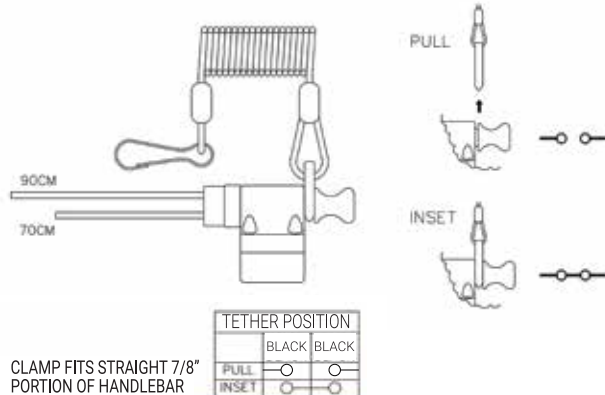

Normally-closed kill switches are used to complete a circuit when the lanyard clip is installed. When the lanyard clip is removed, the circuit is opened, disabling it.

This type of kill switch is wired in series with the machine's ignition switch. If there is any question to which wire should be used, please consult a factory service manual.

TESTING THE KILL SWITCH

To test the kill switch: start your machine. While running, remove the lanyard clip from handlebar mount. This will stall the engine. Then re-insert lanyard clip to reopen the grounded ignition circuit. You should now be able to restart the engine.

NOTE: To prevent injury to yourself or others, this test should always be performed prior to riding your machine to assure the Kill Switch and wiring are in proper working order. You should have a professional motorcycle technician install this switch if you are not familiar with wiring.

PROPER USE OF THE KILL SWITCH

The lanyard clip must be physically attached to the rider in a secure manner for proper Kill Switch operation.

BikeMaster assumes no liability for products which are improperly assembled or installed.

CAUTION

Over-tightening the mounting screws WILL damage the housing threads. Tighten to achieve a SNUG fit. Before mounting switch, remove all grease and residue from handlebar to assure a non-slip fit.