



motoalliance

MOTOALLIANCE PLOW MOUNT MA11102 Polaris Sportsman 500 Touring, 700, 800

Thank you for purchasing our MotoAlliance plow mount(s). You now own a premium, custom plow mount to allow you to use your plow with your ATV. Please note the following instructions and heed all warnings.

- Your ATV and/or plow system can cause death or injury, please use caution and common sense when operating your unit.
- Read your Plow Operator's Manual, your Winch Operator's Manual, and all warning labels before operating your ATV.
- Operate your ATV at a walking speed with the blade installed. Do not exceed 5 mph (8 km/h) even with the blade up.
- Do not operate the ATV on slopes greater than 10 degrees with the plow installed.
- Always lower the plow to the down position before leaving your ATV unattended.

SEVERE INJURY OR DEATH MAY RESULT IF YOU ARE NEGLIGENT.

PARTS LIST:

<i>Item Number</i>	<i>Description</i>	<i>Qty</i>
A1	Plow Mount	1
A2	Clamp Bracket	1
B1	1/4"-20 Hex Head Bolt	4
B2	1/4" Flat Washer	4
B3	1/4"-20 Lock Nut	4
C1	5/16"-18x2" Hex Head Bolt	1
D1	5/16"-18x1" Hex Head Bolt	3
D2	5/16" Flat Washer	3
D3	5/16"-18 Lock Nut	3

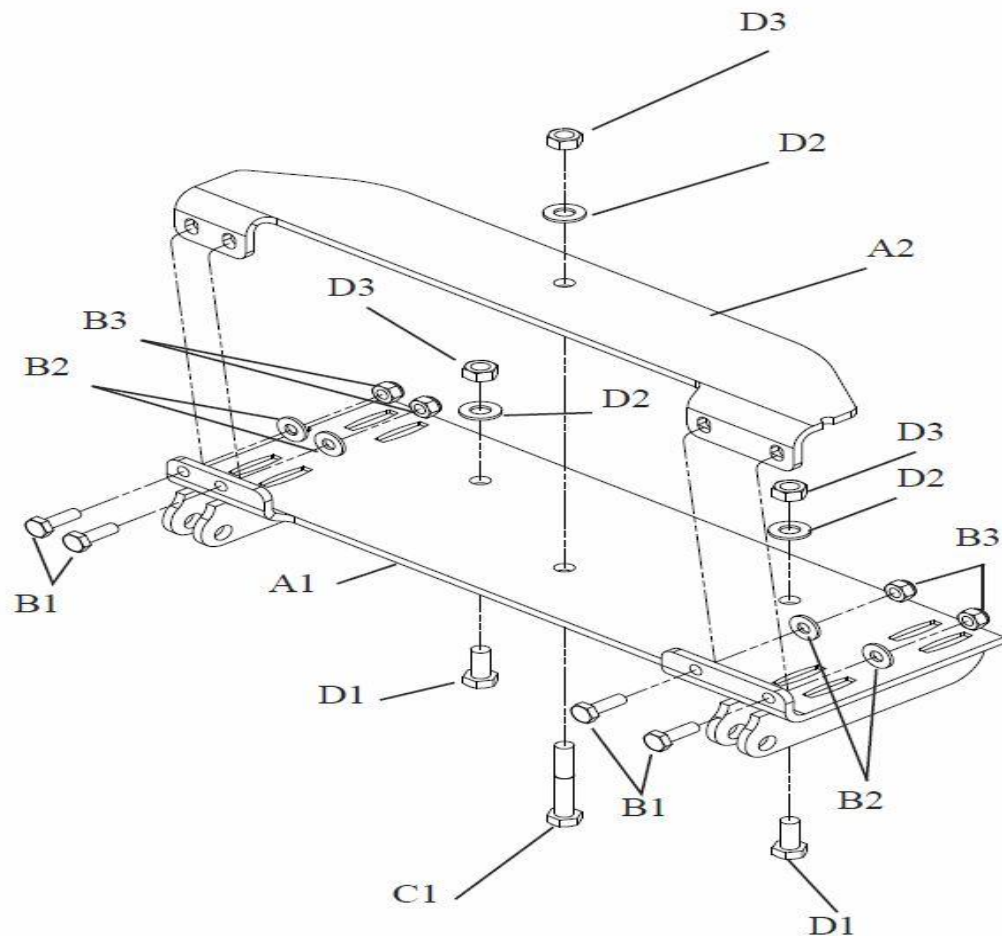

Plow Mount Assembly:

1. Locate the factory skid plate under the ATV (Figure 1).

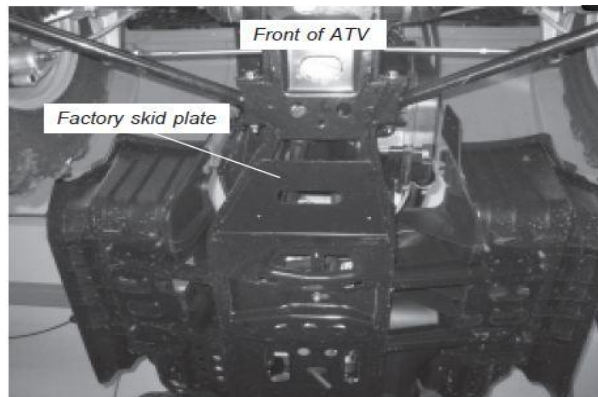

Figure 1

2. Place the plow mounting bracket (A1) so that the rear of the bracket rests on the "lip" of the factory skid plate. (Figure 1 and Figure 2)
3. Next, slide the plow mounting plate (A1) to the left so that the right tab rests against the frame. Mark the holes for drilling. (Figure 2)

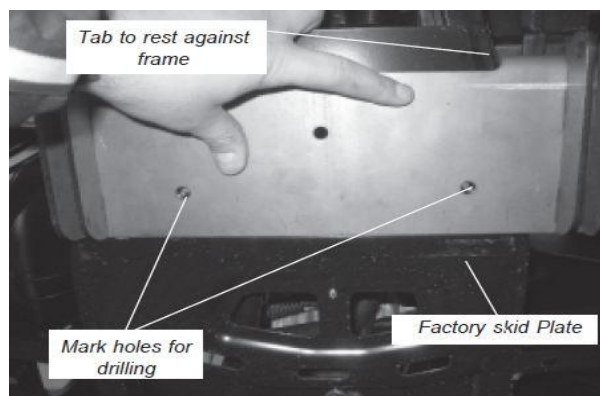

Figure 2

- Using a $\frac{23}{64}$ " drill bit, drill holes into the factory skid plate marked in step two (Figure 3) **Caution:** Make sure the area behind the factory skid plate is clear before drilling.

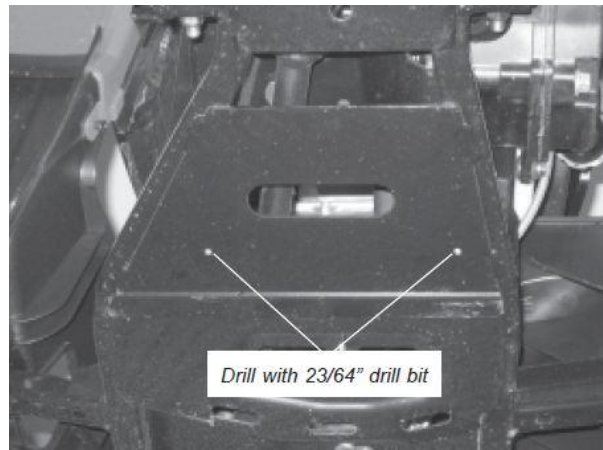

Figure 3

- Attach the plow mounting bracket to the factory skid plate using two $\frac{5}{16}$ "-18x1" hex head bolts (D1), two $\frac{5}{16}$ " flat washers (D2) and two 5/16-18 lock nuts (D3) (Figure 4).

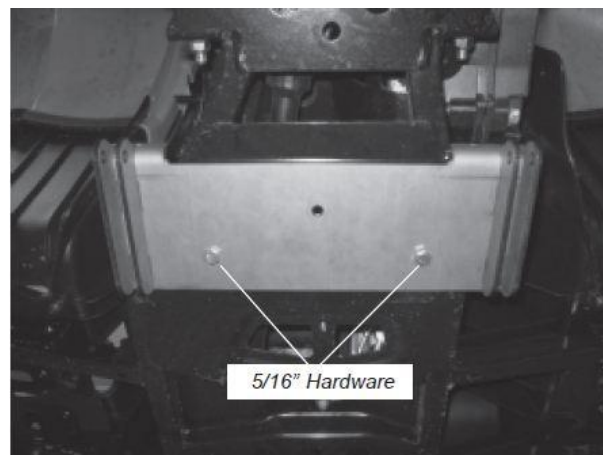

Figure 4

6. Place the clamp bracket (A2) over the frame and behind the tabs of plow mounting bracket (A1) (Figure 5).

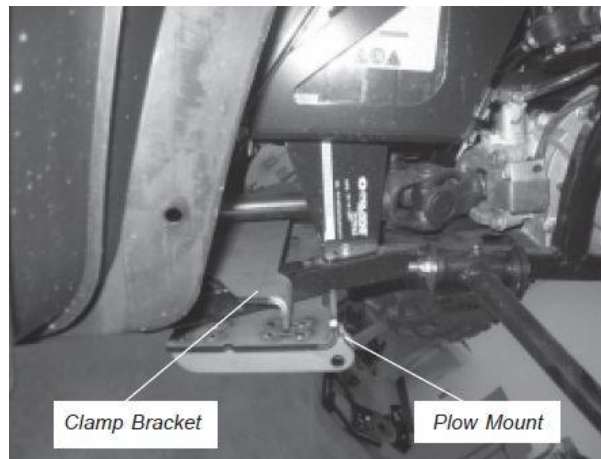

Figure 5

7. Assemble the clamp bracket (A2) to the plow mounting bracket (A1) using four 1/4"-20x1" hex head bolts (B1), four 1/4" flat washers (B2) and four 1/4"-20 lock nuts (B3) (Figure 6).

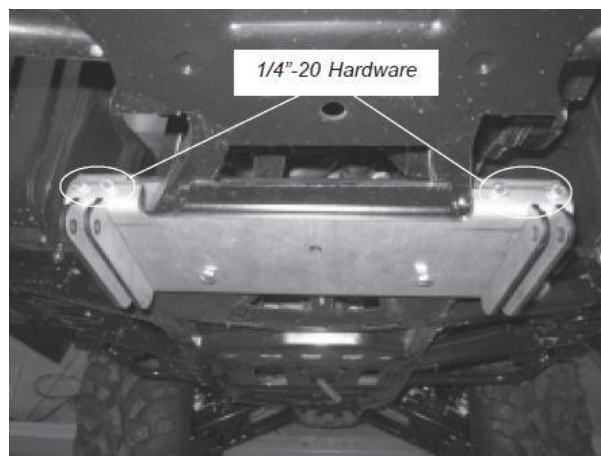

Figure 6

8. Assemble the center of the plow mounting bracket (A1) to the clamp bracket (A2) using one 5/16"-18x2" hex head bolt (C1) and one 5/16" lock washer (D2) and one 5/16"-18 lock nut (D3) (Figure 7).

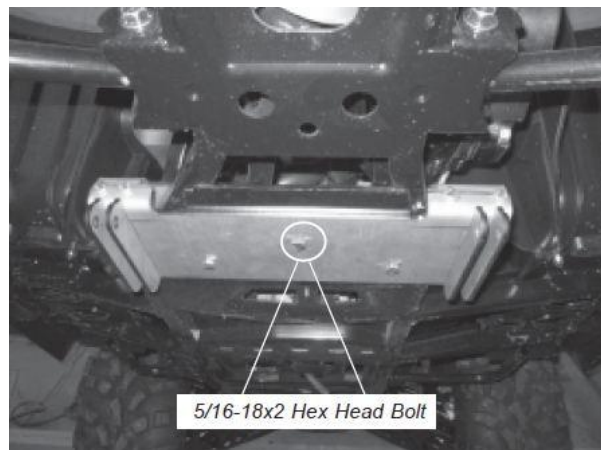

Figure 7

Plow Installation:

1. Slide the plow into position with the tubes under the ATV. Lift the end of the tube assembly into position so the holes in the tube wings line up with the 3/8" holes in the frame brackets.
2. A Phillips head screwdriver may be used to align the holes. Insert both 3/8" pins and hook the retaining clips on the ends of the pins to secure the plow to the ATV.
3. The plate should now be a permanent part of your ATV and will not interfere with clearance. The plow can be easily attached and detached on the welded u-bolt with the clevis hook on a winch or a manual lift assembly.