

Fuel Tires



The Gripper A/T features a bold off-road look that instantly transforms any vehicle. The aggressive, high-void all-terrain tread features a stiff sidewall to help prevent punctures and bruises under the tread and in the sidewall. Built to improve stress distribution, tread life and wear the Gripper A/T is your go-to tire for the daily driven off-road truck or SUV.

Tornado-style pattern design, greatly improving tire grip, also providing you a beautifully simple and elegant appearance.

Small sipes design, providing vastly reduced road noise and heat release, while improving overall ride comfort and tire service life.

Deepening the tires groove design, greatly improving the wear resistance of the tire.

Thicker base rubber design, making the tire more difficult to puncture

Double seamless Wrap Tape, providing enhanced tightening to further improve tire speed, durability and impact resistance.

Double-layer high-strength belt steel wire to ensure the performance of the tire.

Special airtight formula to ensure tire tightness.

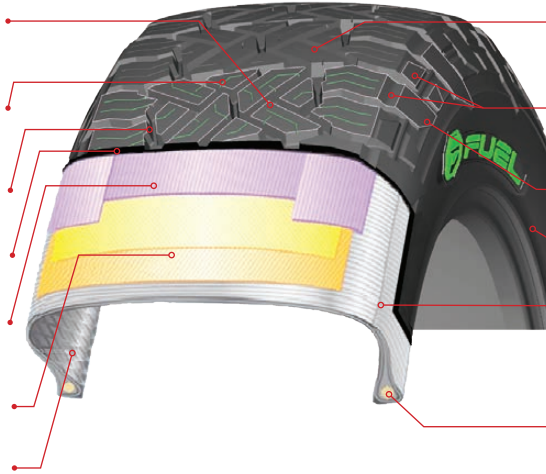

All-terrain pattern design provides strong tear resistance, keeping excellent grip on a variety of roads.

Shoulder concave-convex design, greatly improving lateral grip, allowing for maximum tire control in mud or sand.

Box pattern extends to the sidewall, to ensure the side of the impact resistance.

The Rim Protector Design protects the rim from shock damage.

Double-layer reinforced polyester matrix material, providing improved tire stability at high speeds, while also improving durability and impact resistance.

A single high-strength steel wire is wound seamlessly, so that the tire and rim are closely integrated to further ensure tire safety.

Size (metric)	Part Number	Weight (lbs.)	Load Range	Max Load (lbs.)	Rim Range (inch)	Max PSI	Diameter (inch)	Width (inch)	Warranty (miles)
LT265/70R17	RFAT 26570R17	49.1	E/10PR	3195/2910	7.0 - 8.0 - 8.5	80	31.7	10.7	50000
LT285/70R17	RFAT 28570R17	56.2	E/10PR	3195/2910	7.5 - 8.5 - 10.0	80	32.8	12.7	50000
P275/65R18	RFAT 27565R18	40.1	STD	2601	7.5 - 8.0 - 9.0	36	32.1	11.0	55000
LT285/65R18	RFAT 28565R18	70.5	E/10PR	3640/3305	8.0 - 8.5 - 10.0	80	32.6	11.5	50000
LT295/70R18	RFAT 29570R18	65.6	E/10PR	4080/3750	7.5 - 8.5 - 10.0	80	34.3	11.8	50000
275/55R20	RFAT 27555R20	48.0	XL	2833	7.5 - 8.5 - 9.5	42	31.9	11.2	55000
LT285/55R20	RFAT 28555R20	60.8	E/10PR	3525/3195	8.0 - 9.0 - 10.0	80	32.4	11.7	50000
LT305/55R20	RFAT 30555R20	70.1	E/10	3195/2910	8.5 - 9.5 - 11.0	65	33.2	12.4	50000
LT325/60R20	RFAT 32560R20	75.3	E/10PR	3740/3415	9.0 - 9.5 - 12.0	80	34.8	13.0	50000
LT285/50R22	RFAT 28550R22	64.2	E/10PR	3525/3195	8.0 - 9.0 - 10.0	80	33.27	11.69	50000
LT325/50R22	RFAT 32550R22	76.1	E/10PR	3860	9.5 - 10.0 - 12.0	80	34.8	13.3	50000
305/30R28	RFAT 30530R28	62.4	XL	2756	10.5 - 11.0 - 12.0	50	35.2	12.6	55000



Pictured: 325/605R20 Shown with 20x10 Triton - D581 black and milled



Also available is the first 28" dually load rated tire on the market. The Gripper A/T 305/30/28 is a monster of a tire perfect for your dually truck.

THE DO EVERYTHING,
GO EVERYWHERE,
EVERYDAY TIRE.

Fuel Off-Road Tire Gripper M/T. If you want aggressive styling and superior traction don't look any further. Fuel Gripper M/T tires have it covered and are a perfect match for the fuel wheel line-up.

Small Sipes can reduce heat generation.

Large blocks on tread pattern increase grip off road.

Tire shoulder block design, improve lateral grip and impact resistance.

Large deep groove pattern, greatly improves grip while providing higher wear resistance.

Two layer seamless wrap tape to tighten tires to further enhance high speed durability and impact resistance.

Double-layer high-strength belt steel wire to ensure the performance of the tire. Special airtight formula to ensure tire tightness



Large block pattern design extends to the sidewall, greatly improving the sidewall impact resistance.

Sidewall protruding small pattern, to further improve the sidewall impact resistance.

Thick Base Rubber Design, to protect the tire is not easy to puncture.

The Rim Protector Design protects the rim from shock damage.

3-Ply polyester sidewall carcass design improves tire stability at high speeds, while also improving durability and impact resistance.

Single high-strength steel wire seamless seaming, so that the tire and the rim tightly integrated to further protect the tire safety.

Size (standard)	Part Number	Weight (lbs.)	Load Range	Max Load (lbs.)	Rim Range (inch)	Max PSI	Diameter (inch)	Width (inch)
33x12.50R17LT	RFNT 331250R17	70.5	E/10PR	3085	8.5 - 10.0 - 11.0	80	33.0	12.8
33x12.50R18LT	RFNT 331250R18	69.4	E/10PR	2910	8.5 - 10.0 - 11.0	80	33.0	12.7
33x12.50R20LT	RFNT 331250R20	67.2	E/10PR	2600	8.5 - 10.0 - 11.0	65	32.8	13.0
33x12.50R22LT	RFNT 331250R22	66.1	E/10PR	2270	8.5 - 10.0 - 11.0	65	32.8	13.4
35x12.50R17LT	RFNT 351250R17	76.2	E/10PR	3640	8.5 - 10.0 - 11.0	80	34.8	13.2
35x12.50R18LT	RFNT 351250R18	74.9	E/10PR	3415	8.5 - 10.0 - 11.0	80	35.0	13.2
35x12.50R20LT	RFNT 351250R20	73.8	E/10PR	3195	8.5 - 10.0 - 11.0	80	35.0	13.0
35x12.50R22LT	RFNT 351250R22	71.6	E/10PR	2835	8.5 - 10.0 - 11.0	65	35.0	12.8
35x13.50R20LT	RFNT 351350R20	76.0	E/10PR	3525	8.5 - 11.0	80	35.0	13.5
35x13.50R24LT	RFNT 351350R24	73.8	E/10PR	2910	8.5 - 11.0	65	34.7	13.6
37x13.50R17LT	RFNT 371350R17	83.7	E/10PR	4300	8.5 - 10.0 - 11.0	65	37.0	14.3
37x13.50R20LT	RFNT 371350R20	84.8	E/10PR	3860	8.5 - 11.0	65	37.0	14.0
37x13.50R22LT	RFNT 371350R22	82.6	E/10PR	3420	8.5 - 11.0	65	37.0	14.0
37x13.50R24LT	RFNT 371350R24	79	E/10PR	3085	8.5 - 11.0	80	36.7	13.6
37x13.50R26LT	RFNT 371350R26	79.8	D/8PR	2385	9.5 - 11.0 - 12.0	50	37.0	14.0
38x15.50R20LT	RFNT 381550R20	87.3	D/8PR	3640	11.0 - 12.0 - 14.0	65	37.7	15.4
38x15.50R22LT	RFNT 381550R22	91.4	D/8PR	3525	11.0 - 12.0 - 14.0	50	38.0	15.9
40x15.50R24LT	RFNT 401550R24	108	D/8PR	3970	11.0 - 12.0 - 14.0	65	39.7	15.9
40x15.50R26LT	RFNT 401550R26	105.3	E/10PR	3860	11.0 - 12.0 - 14.0	65	39.7	15.8



GRIPPER M/T TIRES

THE I DON'T
CARE IF IT'S
MUDDY TIRE.

35x12.50R18LT Shown with 18x9.0 D557 Anza

To complete the package we're excited to offer DOT approved Fuel Trail Gripper UTV tires. Tested in some of the toughest conditions, so you'll never end your adventure early. The Trail Gripper UTV is a DOT approved tire that's strong enough to blast through the open desert and channeled to cut deep into the mud and loam.



Size	Part Number	Weight (lbs.)	Load Range	Max Load (lbs.)	Rim Range (inch)	Max PSI	Diameter (inch)	Width (inch)	Tread Construction	Side Construction
28x10-14R	RFUT281000R14	41.0	8PR	900	6.5 - 8.5	22	28.0	10.0	4N+2N	4N
30x10-14R	RFUT301000R14	45.2	8PR	1113	6.5 - 8.5	22	30.0	10.1	4N+2N	4N
30x10-15R	RFUT301000R15	43.0	8PR	1113	6.5 - 8.5	22	30.0	10.0	4N+2N	4N



On the move the Fuel Trail Gripper UTV provides all the traction you need to rip through the desert or crawl through a greasy rock garden.

Pictured: 30x10-15Rs Shown with 15x7.0 Anza - D557



THE WHERE WE'RE
GOING WE DON'T
NEED ROADS TIRE.



D558 Anza 15x7.0 / 30x10-15R Trail Gripper