



## Polaris Sportsman Lift Kit

### Read before Installation

This product is designed for use on ATVs and/or RUVs to increase ground clearance and fender clearance. Purchasers should be aware that use of this product may increase the frequency of required maintenance, part wear, and will raise the center of gravity on your ATV and/or RUV, increasing risk of roll-over, injury and death on all types of terrain. It is your responsibility to always inform other operators and passengers of this vehicle about the added risks.

High Lifter Products, products are designed to best fit users ATV/RUV under stock conditions. Adding, modifying, or fabricating any OEM or aftermarket parts will void warranty. High Lifter Products, products could interfere with other aftermarket accessories. If the user has aftermarket products on machine, contact High Lifter Products to verify that they will work together. Adding aftermarket suspension components and/or more aggressive tires can cause breakage of other OEM driveline components such as differentials, axles or drive shafts.

We recommend that wider tires and/or wheel spacers be used to achieve a wider stance and to improve stability of the ATV and/or RUV. Riders should be advised that the handling characteristics of a taller ATV and/or RUV are different and require extra care when riding, particularly on side hills or off-camber situations. If you further raise the center of gravity by adding taller tires, heavy loads to racks or seats, or by any other means, the ATV and/or RUV must be operated with even more care, at slower speeds and on relatively flat ground. All turns should be done at a slow speed, even on level ground.

Operation of an ATV and/or RUV with or without modified suspension components, while or shortly after consuming alcohol or drugs, subjects the rider to the risk of serious bodily harm or possible death. This risk is compounded if the rider does not wear an approved helmet and other safety gear. High Lifter urges that all approved safety gear be worn when riding an ATV and/or RUV as a driver or passenger.

By purchasing and installing High Lifter Products, products, user agrees that should damages occur, High Lifter Products will not be held responsible for loss of time, use, labor fees, replacement parts, or freight charges. High Lifter Products will not be held responsible for any direct, indirect, incidental, special, or consequential damages that result from any product purchased from High Lifter Products. The total liability of seller to user for all damages, losses, and causes of action, shall not exceed the total purchase price paid for the product that gives rise to the claim.

### Dealers and other Installers

You are responsible for informing your customer and end user of the information contained above and the increased potential hazards of operating an ATV and/or RUV equipped with modified suspension components. If you install any suspension modifying components, it is your responsibility to also install the warning label prominently in view of the driver and in prominent view of the driver and passenger on RUVs and multi-passenger ATVs. They should also be instructed to notify anyone operating the vehicle, as well as any passengers, that said vehicle is modified.

As discussed above, it is critically important that they be instructed in the need for slower speed operation, regardless of terrain, after this lift kit is installed.

### **SPORTSMAN 800/500 INSTALLATION NOTES FOR 2011 MODELS:**

**On 2011 models the customer MUST upgrade to a HLP rear axle bar replacement kit (ABK-P-2) OR upgrade the rear factory CV axles with HLP PRO SERIES axles or GORILLA axles!!! On 2011 models with a lift kit installed the rear axles bind when the suspension is at full extension/droop and are subject to break.**

# Parts Diagram

Front Large Spacer (2ea)



Rear Spacer (2ea)



Front Small Spacer (2ea)



3/8 x 2 1/2 Bolt (4ea)



3/8 Lock Nut (4ea)



Hex Bar (2ea)



Right Side Rear Paring

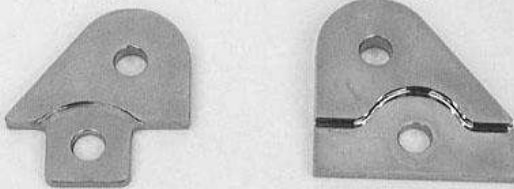

Left Side Rear Paring

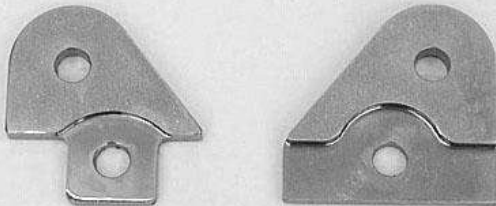

Left and Right is from seated position

High Lifter Logo Plate (1ea)



## Front Lift

- 1) Place jack under center of ATV front end and lift until front wheels clear the ground. Be careful to support ATV properly so that it is secure, but so that the A-arms and shocks can drop to full extension.
- 2) Remove front wheels.
- 3) Disconnect the front control arm, hub, brake assembly, tie rod, and axle. Slide the hub off the axle.

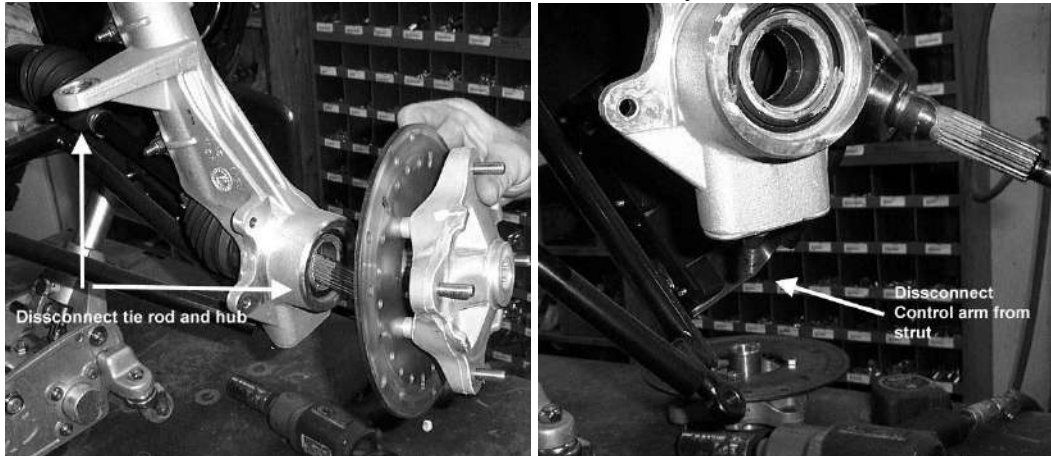

- 4) There are two ways you can install the lift. You can take the strut and springs completely off. If you do this, then the front plastic will need to come off on the newer models. We are going to show you a "short cut" method.
- 5) Leaving the top of the strut connected to the frame loosen the two bolts on the back of the strut. This will allow the strut to slide off the strut cartridge and away from the spring.

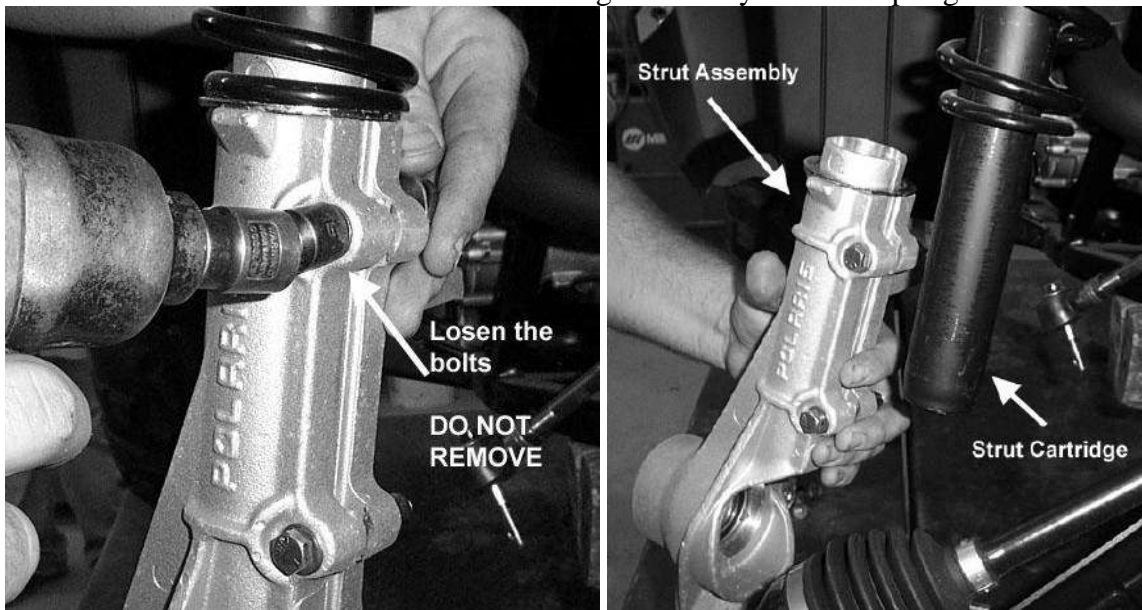

- 6) Next you will need to grind the strut to clearance the CV boot and keep it from rubbing on the strut once the lift kit is installed.

- 7) You will need to remove about a 1/4" of the housing. We used a grinder. Make sure to remove enough so you do not need to go back and regrind.

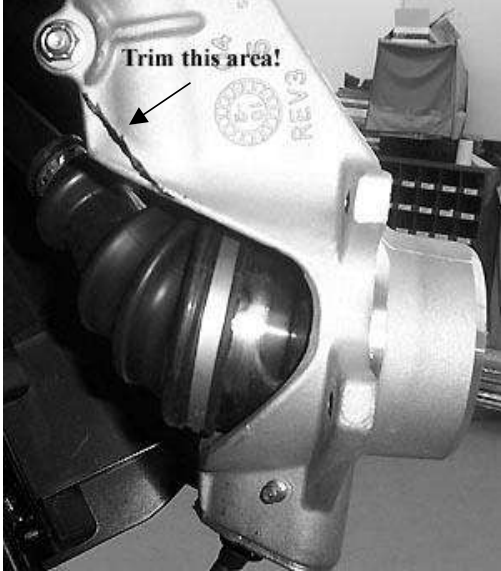

- 8) Once you have completed the grinding, drop the small front spacer into the bottom of the strut socket and place the large front spacer on the top of the strut over the large OE washer. Make sure to place the large spacer with the lip on top for the spring to nest in.



9) Slide the strut cartridge back into the socket.



**10) This is the part about the short cut we talked about earlier!**

11) Once you have assembled the lift brackets in place and have loosely attached the strut to the strut cartridge insert the axle and attach the control arm to the bottom of the strut assembly.

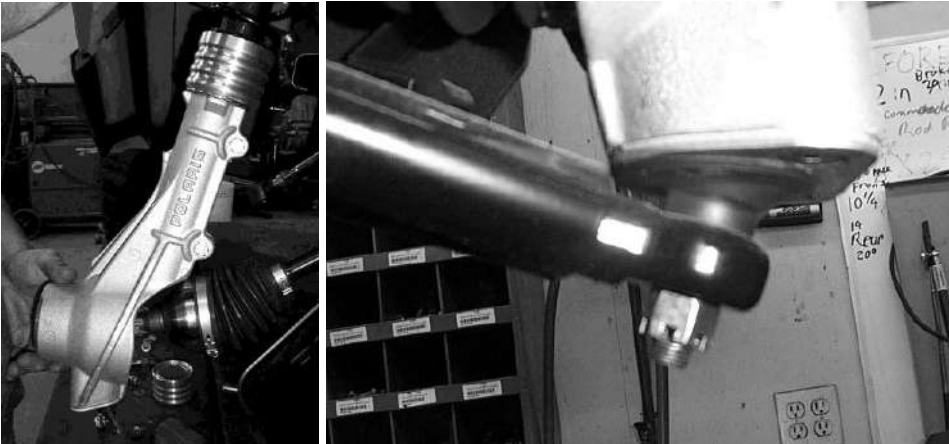

12) With the ATV still jacked up, place a block of wood or another solid object under the control arm.



- 13) Lower the jack, this will place weight on the end of the strut that is connected to the control arm. This will compress the spring and strut. Fasten the two bolts on the back of the strut.

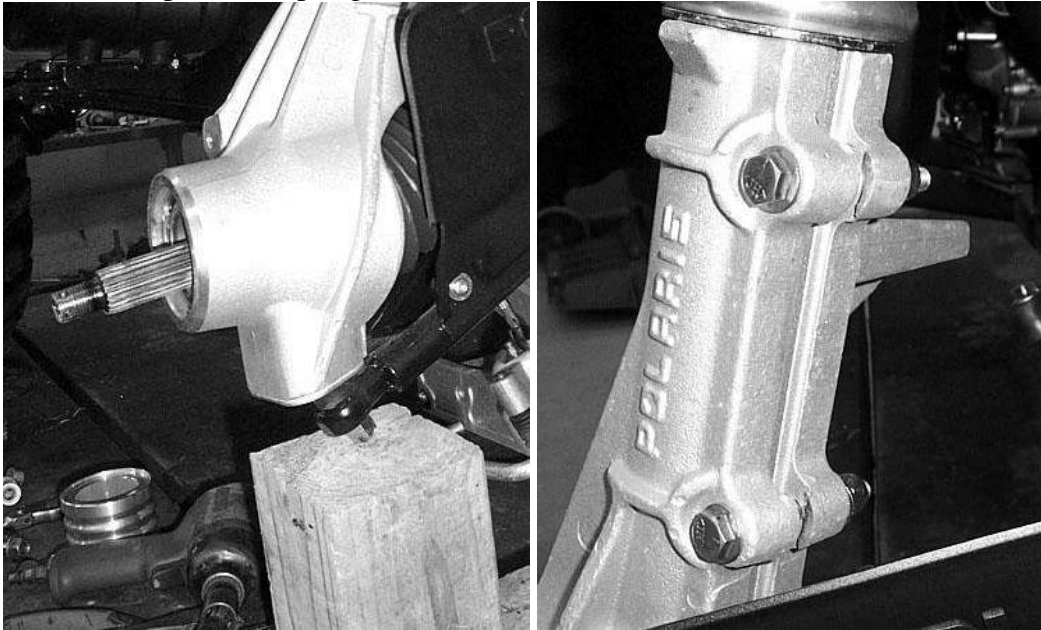

14) Reconnect the tie rod, hub, and brake assembly.

15) Repeat this process on the other side.

**16) Check the boots on the axles for clearance in the strut housing.**

17) Install the wheels, torque wheel lug nuts to manufacturer's specifications, lower and remove jack.

Check for clearance problems or misalignment. (Re-torque lug nuts after first ride.)



## Rear Lift

- 1) Place jack under ATV at the rear of the bottom skid plate and lift until the weight is off the suspension. Be careful to secure the ATV properly so as not to fall off the jack.
- 2) Remove the rear wheels and disconnect the lower portion of the shock from the control arm.
- 3) Disconnect the top bolt from the rear hub assembly.

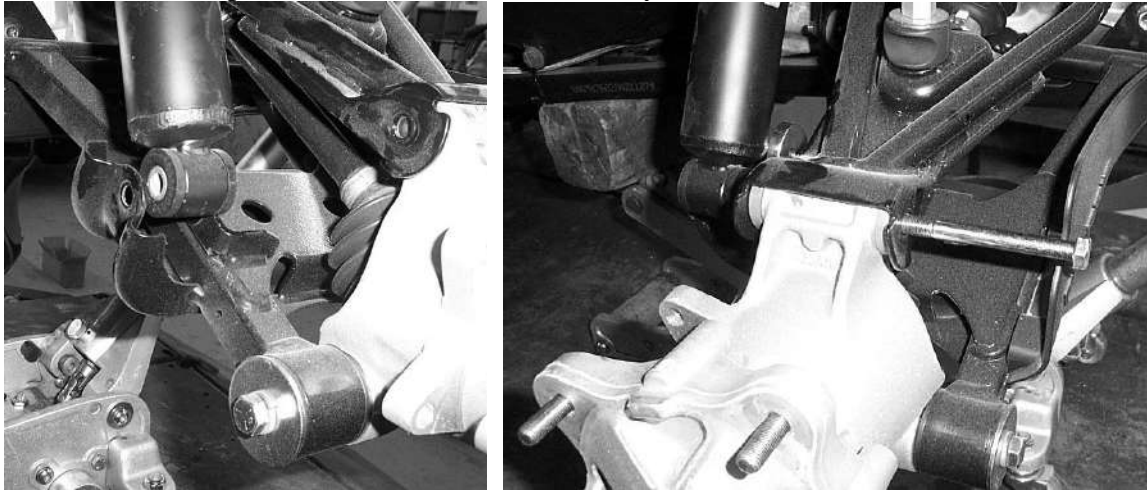

- 4) There are 4 different rear lift brackets. There are two for the left side and two for the right side. Each one is different.
- 5) Locate the brackets for the side you are starting with first. Now connect them to the ATV rear lower control arm.

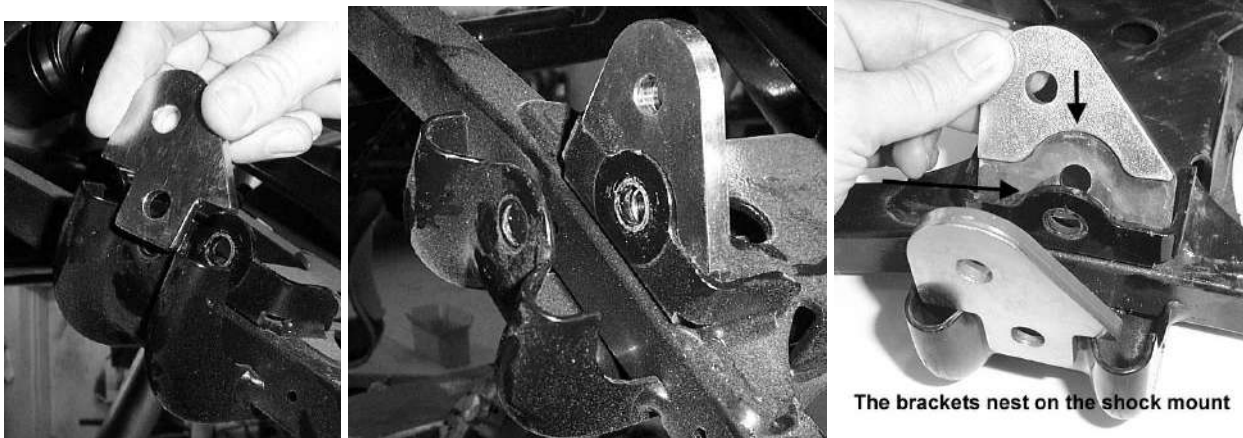

- 6) The brackets must be installed according to the photo. The brackets are designed to nest onto the shock mount with the angle pointing "Up Hill"



7) Connect the brackets and spacer to the control arm using a 3/8 x 2 1/2 hex bolt and 3/8 lock nut.

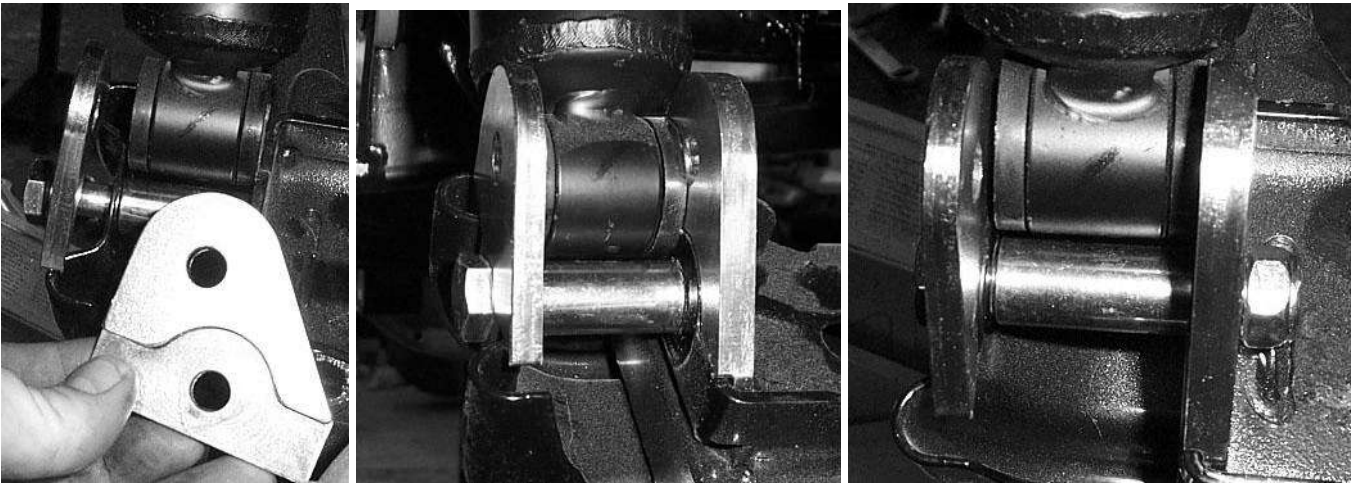
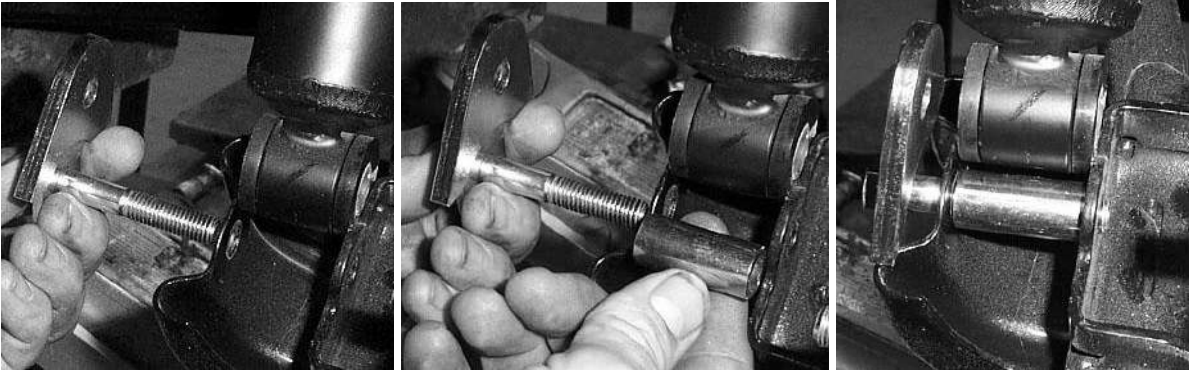

8) Now connect the bottom of the shock the lift bracket using 3/8 x 2 1/2 hex bolt and 3/8 lock nut.

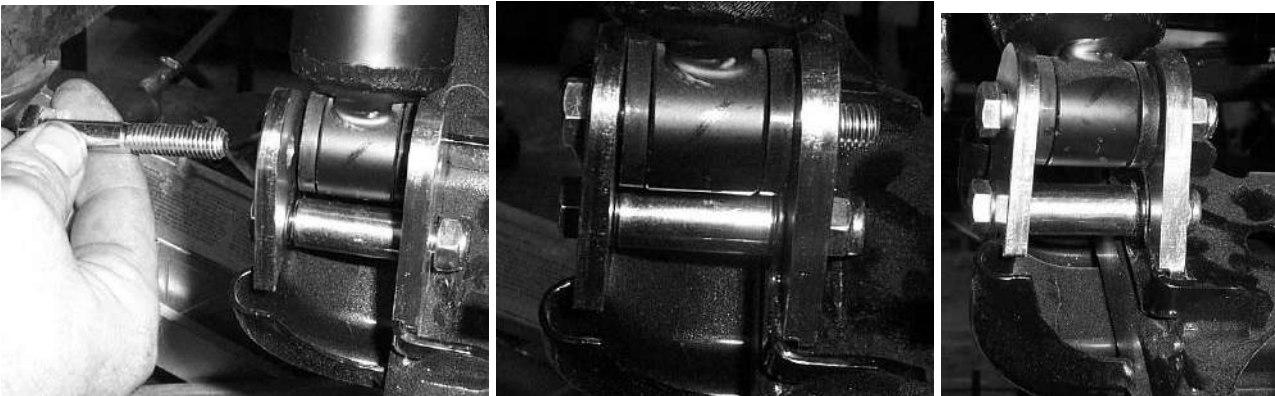

- 9) Remove factory the torsion bar bracket and install new bracket on the torsion bar and axle using the factory bolts. This bracket is just like the factory bracket except it is slightly longer.

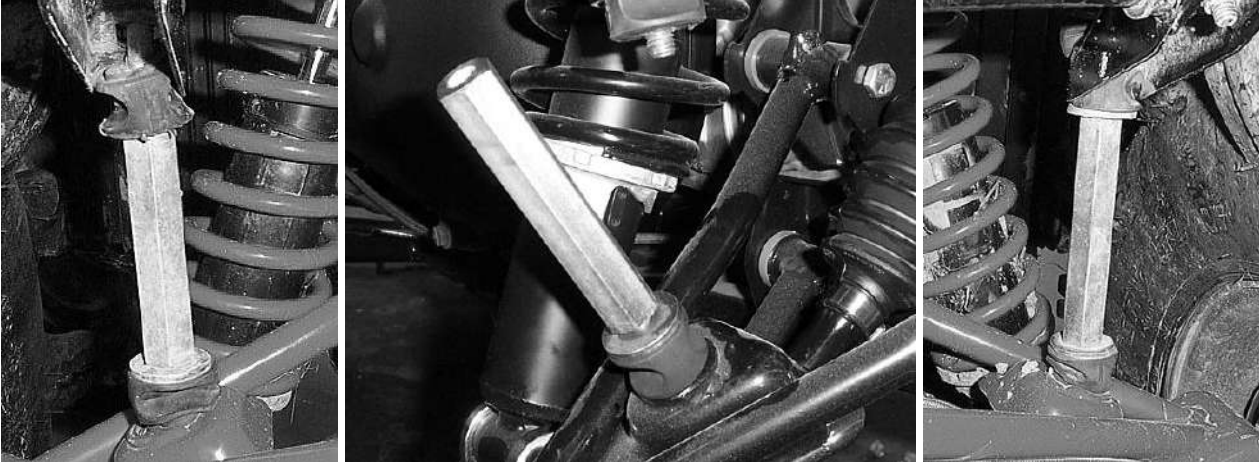

- 10) Reattach the top of the hub to the upper control arm  
11) Repeat this process on the other side.  
12) Tighten all bolts to manufacturer's torque specifications. Install the wheels, torque wheel lug nuts to manufacturer's specifications, lower and remove jack. Check for clearance problems or misalignment.  
13) Re-torque lug nuts after the first ride.

#### High Lifter Logo Plate

1. On the back of the ATV there are two bolts located on either side of the differential.
2. Remove the two nuts.
3. Place the logo plate over the two bolts and then secure it with the stock nuts there were removed earlier.

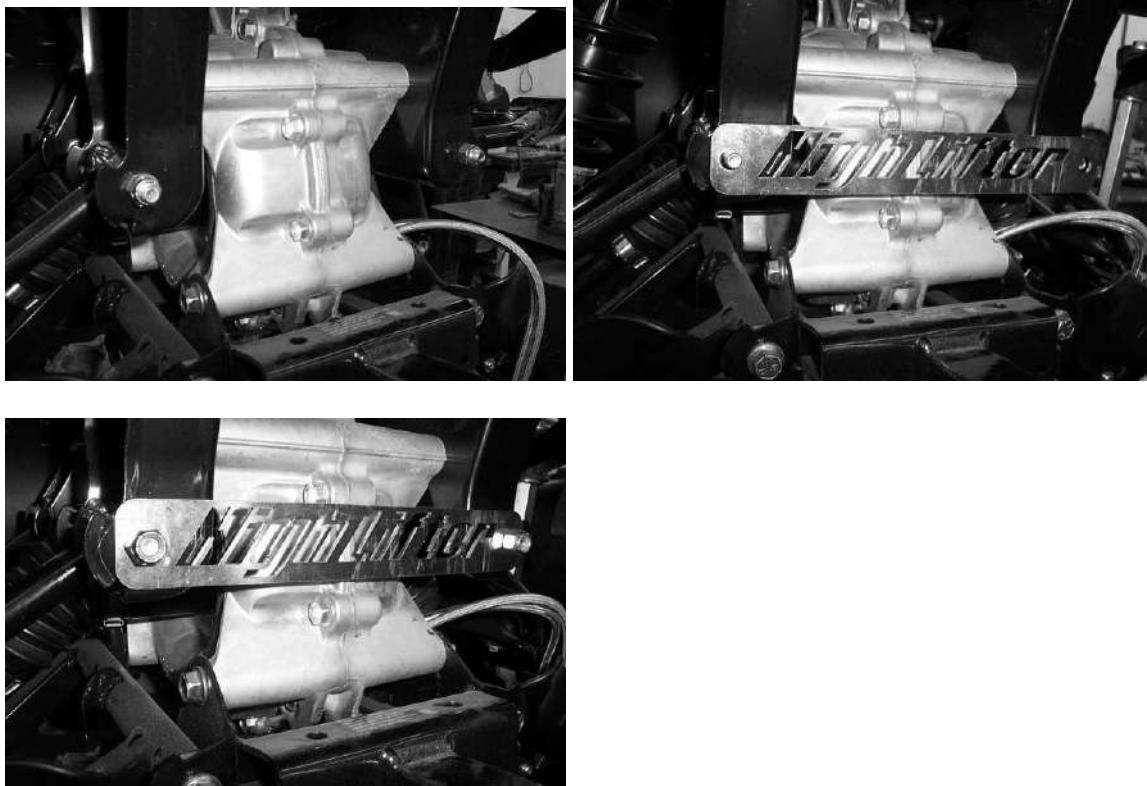



### **High Lifter Lifetime Warranty**

From the beginning, High Lifter has engineered and manufactured some of the toughest, most durable products on the market. That's why this product comes with a Lifetime Warranty. It's our promise that High Lifter will never let you down.

- The **Lifetime Warranty** covers products sold to the original purchaser only and is not transferable. The term of the warranty is for the lifetime of the vehicle in question.
- Normal wear and tear items and finishes, such as, but not limited to: Heim joints, tie rod ends, ball joints, bearings, seals, bushings, bushing sleeves, zinc plating , powder coating, or chipping and discoloration of any finish is not covered.
- High Lifter will ship the replacement product after the returned product has been inspected by High Lifter staff.
- The warranty shall not include claims for damages, installation time or labor charges, economic losses, inconvenience, transportation, towing, down time, direct or indirect or consequential damages or delay resulting from any defect.
- The warranty does not apply to products that have been improperly applied or improperly installed.