



Yamaha 350 Big Bear/400 Kodiak Lift Kit

Read Before Installation!

This product is designed for use on ATVs on which additional ground clearance and fender clearance is desired. It is designed for utility type, slower-speed use on relatively flat terrain in deep mud or snow. Although we have many thousands of satisfied lift kit customers and over 400 franchised dealers selling and installing lift kits, purchasers should be aware that use of this product may increase the frequency of required maintenance, part wear, and will raise the center of gravity on your ATV increasing risk of roll-over on side hills, ditches or other steep terrain.

We recommend that wider tires and/or wheel spacers be used to achieve a wider stance and to improve stability of the ATV. Riders should be advised that the handling characteristics of a taller ATV are different and require extra care when riding on side hills or off-camber situations. If you further raise the center of gravity by adding heavy loads to racks or seats, the ATV must be operated with care, at slower speeds or on relatively flat ground.

Operation of an ATV with or without a lift kit, while or shortly after consuming alcohol or drugs, subjects the rider to the risk of serious bodily harm or possible death. This is compounded if the rider does not wear an approved helmet and other safety gear. High Lifter urges that all approved safety gear be worn when riding an ATV.

If this is not what you expected, or is not consistent with your intended use, you should return the product immediately to the seller, before installation, for a refund of the purchase price; less any fees. After installation, product is warranted for 90 days for defects in workmanship and materials. Warranty is limited to refund of the purchase price or replacement of the kit, at the seller's option.

This lift kit contains the following parts:

10x55mm Bolts	4	Pages of Diagrams	3
10mm Nuts	4	Pages of Instructions	2
10mm Flat Washers	4		
12x90mm Bolts	2		
12mm Nuts	2		
Lift Brackets	5		

Front Lift

- 1) Place jack under center of ATV front end and lift until front wheels clear the ground. Be careful to support ATV properly so that it is securely supported but so that A-arms and shocks can droop to full extension.
- 2) Remove front wheels and shocks.
- 3) Slide bottom of lift bracket "A" over A-arm shock mount and insert new 10x55mm bolt.
- 4) Slide bottom of shock into top of lift bracket. Put one flat washer on each side to act as spacers. Insert new 10x55mm bolt through top bracket hole, washers and shock.
- 5) Install top of shock in original location, then install all nuts.
- 6) Repeat the procedure for the other side.
- 7) The brackets should angle inward towards the shock keeping the original shock angle when lift is installed correctly or serious tire damage can occur. (It is OK for the shock to lean in slightly but it should not lean out)
- 8) Tighten all bolts to manufacturer's torque specifications.
- 9) Install the wheels, torque wheel lug nuts to manufacturer's specifications, lower and remove jack. Check for clearance problems or misalignment.

Note: On some models, the stick guard protecting the CV boots will rub the A-arm during full suspension travel when the wheels are turned. In these cases, approximately ¼" of the bottom edge of the factory stick guard must be ground off.

Rear Lift

- 1) Place jack under ATV at the rear of the bottom skid plate and lift until the weight is off of the suspension. Be careful to secure the ATV properly so as not to fall off the jack.
- 1) Remove the shock.
- 2) After removing the shock, jack the ATV up 1"-2" further.
- 3) Insert a new 12x90mm bolt through bracket "C" the shock mount and bracket "B" and install the nut (Notice that bracket "B" is slightly thicker than bracket "C" on the end)
- 4) Install the remaining 12x90mm bolt through the top hole of the lift brackets and shock.
- 5) Install lift bracket "D" on the top lift bracket bolt and differential housing.
- 6) Tighten all bolts to manufacturer's torque specifications.
- 7) Install the wheels, torque wheel lug nuts to manufacturer's specifications, lower and remove jack. Check for clearance problems or misalignment.

PARTS LIST

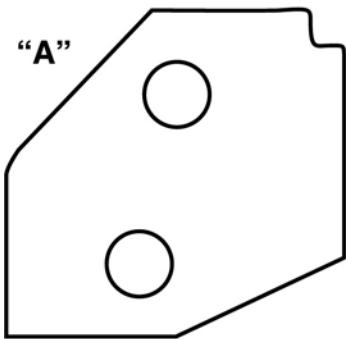

QUANTITY - 2

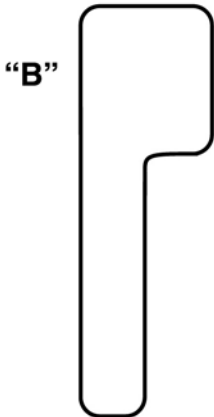

QUANTITY - 1

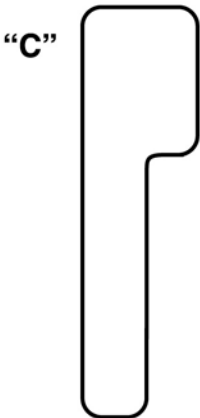

QUANTITY - 1



QUANTITY - 1

FRONT

SHOCK

"A"

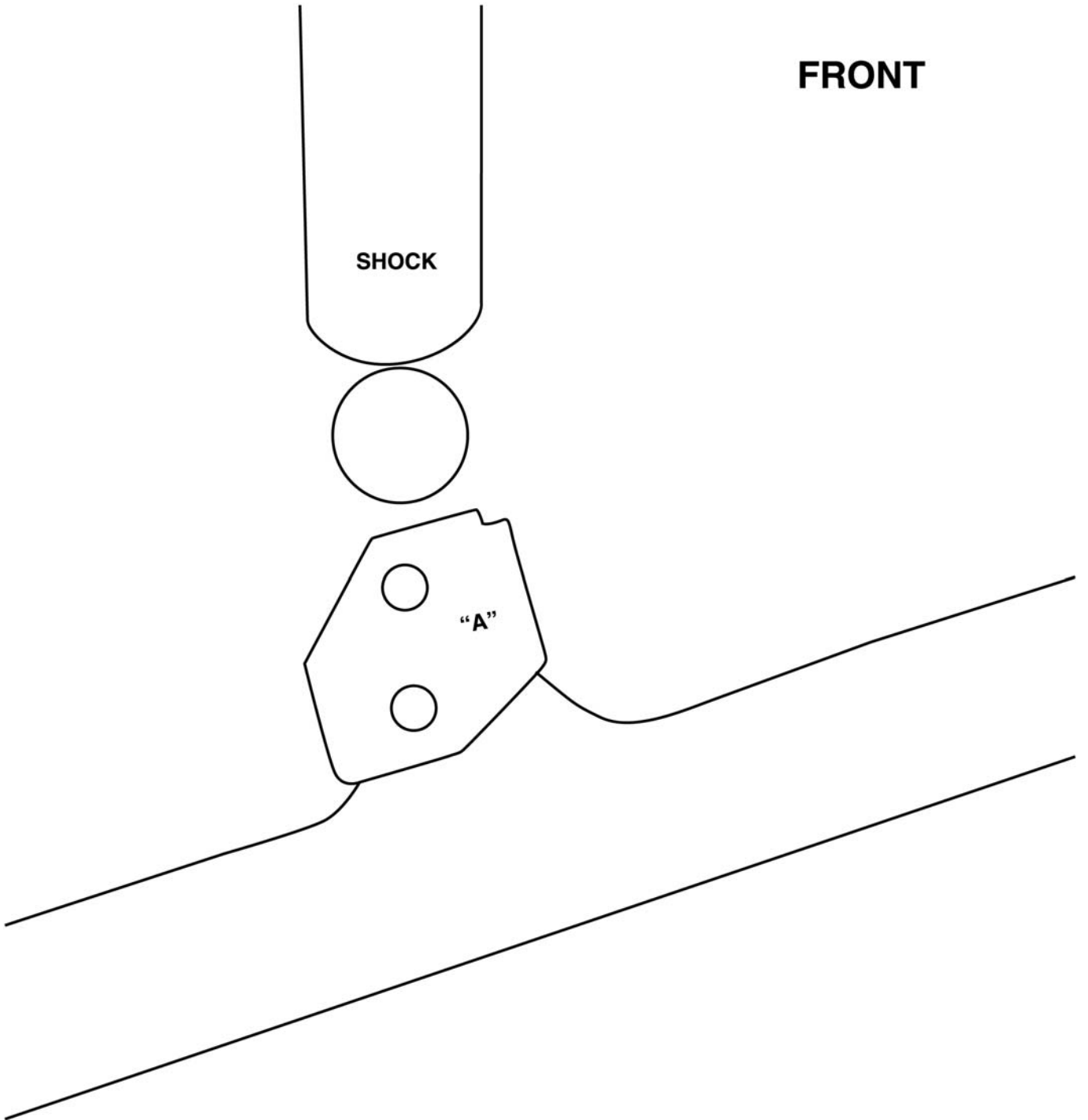

REAR

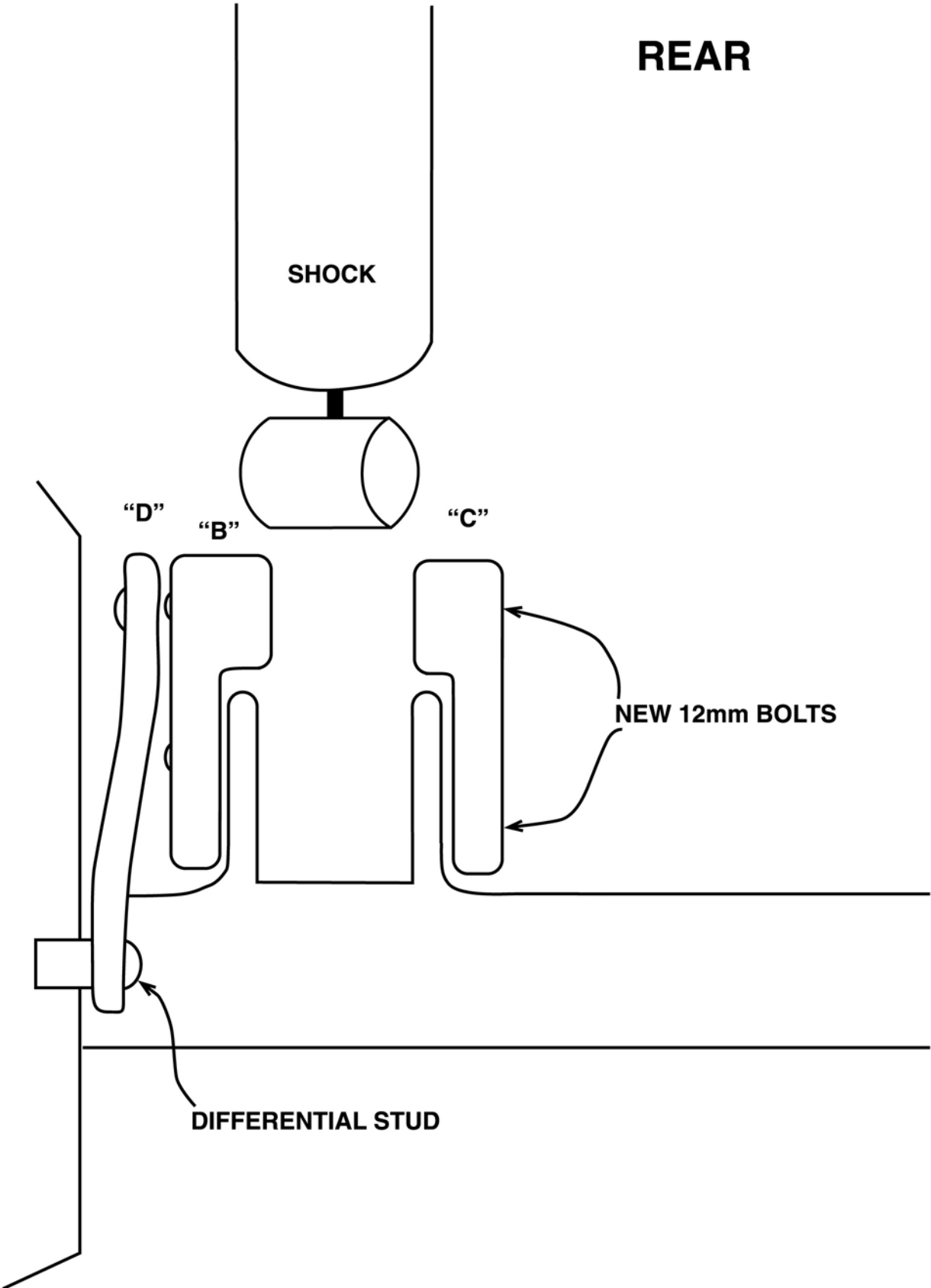

Feel the difference with High Lifter.

Shop for other suspension on our website.