

CAN-AM G2 PLOW MOUNT

Plow Mount PART # 105445
 Hardware Kit: HK-141

Kit Components:

Qty.	Part Description
1.....	Plow Mount Plate
1.....	Plow Mount Bracket
2.....	1" x 1 1/2" Nut
2.....	3/8 x 1 1/4" Carriage Bolt
2.....	3/8 Hex Flange Nylock Nut
2.....	3/8 x 1 1/4" Hex Flange Bolt
4.....	3/8 SAE Flat Washer
2.....	M6 x 25mm Hex Flange Bolt

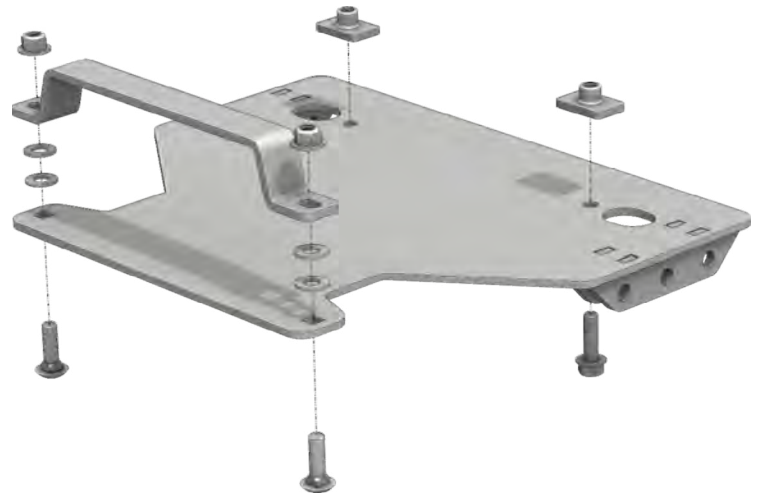

“Figure 1”

INSTALLATION INSTRUCTIONS:

1. Install mount bracket over top of frame just behind the front A-arms as shown in Figure 2.
2. Install mount plate to bracket using the carriage bolts, washers and flange nuts (A) provided with the mount. Use washers as spacers between the bracket and the plate. Leave hardware loose enough to adjust the mount plate.

Note: If the skid plate has been removed there is no need to use the washers and you may skip to step 5.

3. Align the mount plate hole (C) with the hole in the skid plate. Without moving the mount plate tighten down the carriage bolts previously installed.
4. Using the mount plate holes (B) as a template drill two 3/8" holes through the skid plate. Be sure to use caution when drilling through the skid plate as some frames will have pre-installed rivet nuts.

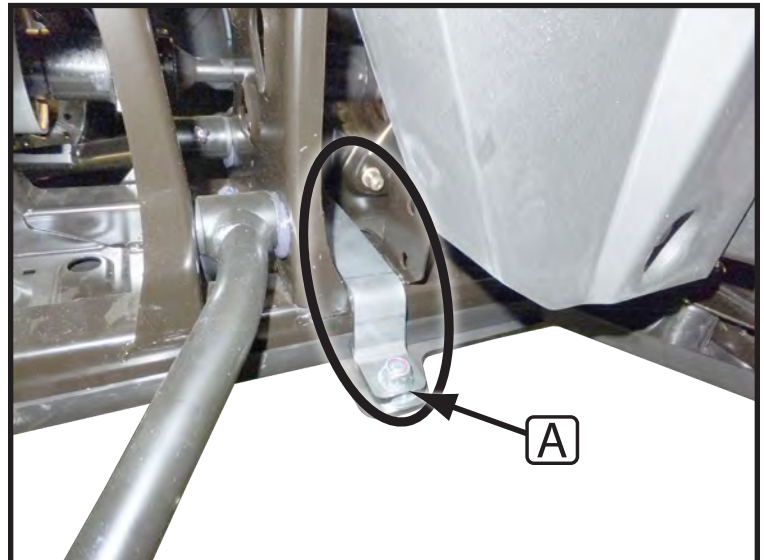

“Figure 2” Bracket Install

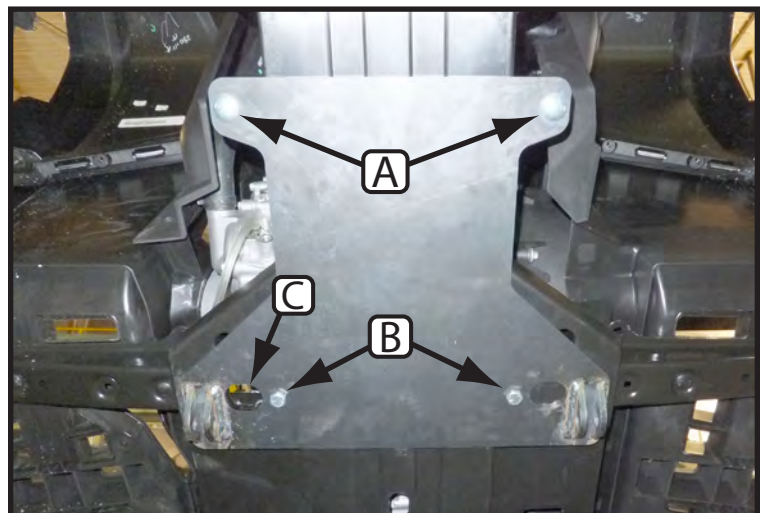

“Figure 3” Mount Plate Install



5. Inspect machine frame for pre-installed rivet nuts in location (D). See Figure 4.

Note: For an example of a rivet nut see Figure 6.

- If it **DOES** have rivet nuts installed you will use the M6 Bolts included in the hardware kit.
- If it **DOES NOT** have rivet nuts installed you will use the 1" x 1 1/2" Nuts and 3/8" Hex Flanged Bolts. Install as shown in Figure 5.

Note: You can drill out the rivet nuts and use the 3/8" hardware, if you do not wish to use the M6 Bolts and are not planning on installing the Can-Am Aluminum Skid Kit.

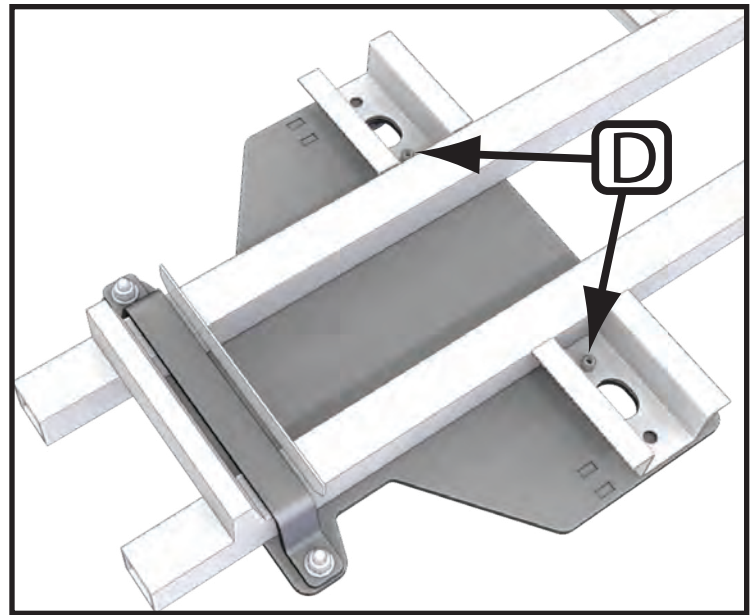

"Figure 4" Rivet Nut Locations

6. Tighten down all bolts.
7. See UTV Plow Tube System instruction manual for tube attachment. See Figure 5 for the default attachment position.

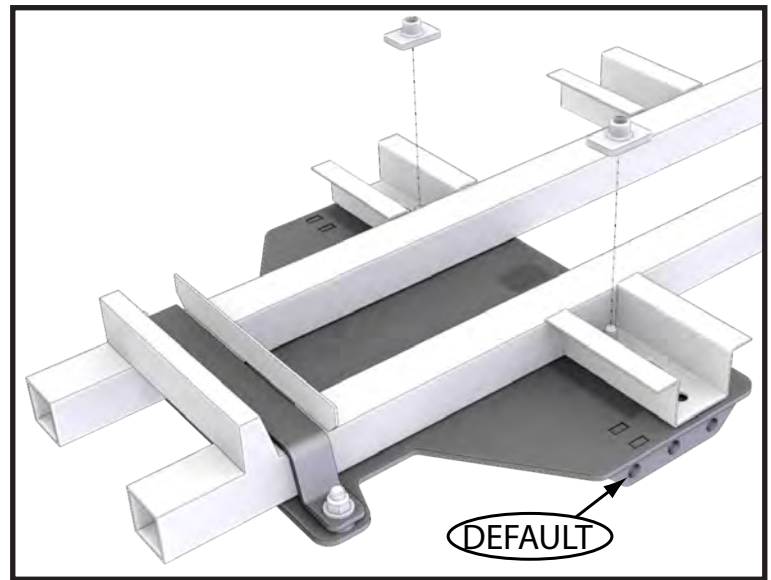

"Figure 5" 1" x 1 1/2" Nut Install



"Figure 6" Rivet Nut Example

