



X3-KIT INSTALLATION MANUAL





X3-KIT

Installation and Operation Manual

This digital PDF is interactive.

Please save ink and paper...



Open interactive manual using Adobe Reader[®]

on [PC, MAC, and all smart devices](#)



X3-KIT

Installation and Operation Manual

Table of Contents

1.	LIST OF FIGURES	5
2.	How to Use this Manual	6
2.1.	Interactive Manual using Adobe Reader	6
2.2.	Your Kit SKU Number and this Manual.....	6
2.3.	Illustration/Photo Details and Orientation.....	6
3.	Safety First.....	7
4.	Application Chart.....	8
4.1.	100% Direct Bolt-On Vehicle List	8
4.2.	**Excluded Vehicles	8
4.3.	Aftermarket Product Compatibility	8
5.	Installation Overview.....	9
5.1.	QUICK INSTALL OUTLINE	9
5.2.	Kit Layout and Locations.....	10
5.3.	Approximate Installation Time	10
6.	List of Tools and Supplies	11
6.1.	Standard Tool List (Required).....	11
6.2.	Special Tool List (Recommended)	11
6.3.	Shop Consumables List (Recommended)	11
7.	Parts List	12
7.1.	Before Starting, Review Parts List	12
7.2.	Pre-Packaged Electro-Mechanical Kit Items.....	12
7.3.	Air Fittings and Related Items	13
7.4.	Electrical Small Components and Related Items.....	14
7.5.	Bolt-On Mounting Brackets & Special Hardware	15
7.6.	Hardware, Fasteners and Soft Parts.....	16
8.	On-Vehicle Mechanical Assembly Steps.....	19
8.1.	Plan Location of Quick Connect Air Coupler.....	19
8.2.	Remove Passenger side Rear Fender	19
8.3.	Remove Driver side Rear Fender	21
8.4.	Air Tank Brackets - Installation.....	21
8.5.	Air Tank Fittings - Bench Assembly.....	24
8.6.	Air Tank - Installation.....	25



X3-KIT

Installation and Operation Manual

8.7.	Air Compressor Bracket - Installation.....	26
8.8.	Air Compressor - Installation.....	28
8.9.	Air Horn - Installation	30
8.10.	Connect Remote Quick Connect Kit to Vehicle	34
9.	On-Vehicle Electrical Installation.....	35
9.1.	Relay and Fuse Diagram for Air Horn System.....	35
9.2.	Review suggested Wire Routing for Air Horn System	36
9.3.	Disconnect Vehicle Battery(s).....	36
9.4.	Connect Wiring to Relay(s) and Fuse(s), then Attach to Vehicle.....	36
9.5.	Install Horn Button	37
9.6.	Connect Air Horn Solenoid(s)	37
9.7.	Pressure Switch	37
10.	Initial Testing of Kit.....	38
10.1.	Reconnect Vehicle Battery(s)	38
10.2.	Test Air Compressor	38
10.3.	Test Train Horns.....	38
10.4.	Test Quick Connect Coupler	38
10.5.	Re-install Rear Fenders.....	38
11.	General Operation of Kit	39
11.1.	Compressor Operation	39
11.2.	Horn Operation.....	39
12.	Routine Maintenance.....	39



X3-KIT

Installation and Operation Manual

1. LIST OF FIGURES

Figure 1 – Top View Showing Kit Layout (2018 X3 2 Door Shown)	10
Figure 2 – Passenger Rear Fender Removal (fasteners on top of fender)	19
Figure 3 – Passenger Rear Fender Removal (fasteners behind door and fender)	19
Figure 4 – Passenger Rear Fender Removal (below tail light)	20
Figure 5 – Passenger Rear Fender Removal (fender resting on tire); Air Tank shown installed	20
Figure 6 – Air Tank Bracket Mounting Locations (side view)	21
Figure 7 – Air Tank Bracket Mounting Locations (top view)	21
Figure 8 – Front Air Tank Bracket stops at corner Gusset (Shown with Air Tank)	22
Figure 9 – Installing Front Air Tank Brackets, Exploded View	22
Figure 10 – Installing Rear Air Tank Bracket, Exploded View	23
Figure 11 – Installing Rear Air Tank Bracket, Proper Bolt Orientation (partial bracket shown)	23
Figure 12 – Air Tank Fittings installed on Air Tank, Exploded View	24
Figure 13 – Air Tank Fittings Orientation (from above vehicle)	24
Figure 14 – Installing Air Tank onto Brackets, Exploded View	25
Figure 15 – Air Compressor Bracket Mounting Locations (side view).....	26
Figure 16 – Air Compressor Bracket Mounting Locations (top view).....	26
Figure 17 – Front Air Compressor Bracket stops at corner Gusset (Shown with Air Compressor).....	27
Figure 18 – Installing Air Compressor Bracket, Exploded View.....	27
Figure 19 – Air Tubing Route from Air Compressor to Air Tank.....	28
Figure 20 – Installing Air Compressor Leader Hose Adapter Bracket	28
Figure 21 – Installing Air Compressor onto Bracket; Exploded View	29
Figure 22 – Air Compressor Filter Remote Tubing shown attached (example vehicle)	29
Figure 23 – Disassembly of Air Horn by Separating Trumpets.....	30
Figure 24 – Carriage Bolts temporarily taped in place on Horn Bracket.....	30
Figure 25 – X3-302 with Rubber U-Trim installed, exploded view.....	30
Figure 26 – Sway Bar Bolts to remove and Brake Line Bolt (looking from above).....	31
Figure 27 – Air Horn Bracket Installed below Brake Lines.....	31
Figure 28 – Installing Trumpet Support Clamp and Trumpets, Exploded View	32
Figure 29 – Installing Air Horn Driver with Tubing attached, Exploded View	33
Figure 30 – Final tightening of Air Horn Brackets and Air Horn	33
Figure 31 – Final installation of 102 Air Horn (X3 Turbo R shown)	34
Figure 32 – Example of Air Coupler Mounted To Bumper	34
Figure 33 – Suggested Ignition Relay Diagram for Air Horn System	35
Figure 34 – Suggested Wire Routing for Horn, Air Compressor, and Pressure Switch	36
Figure 35 – Relay and Fuse location example behind Passenger seat (2019 X3 Turbo RC Shown)	36
Figure 36 – Recommended install location for Air Horn Button	37



X3-KIT

Installation and Operation Manual

2. How to Use this Manual

2.1. Interactive Manual using Adobe Reader

It is recommended to open this digital PDF using Adobe Reader[®] to take advantage of following key features:

- **Hyperlinks** (blue underlined text) allow access to additional content via internet; click/tap to activate
 - Includes Installation Figures and "Figure xx"
- **Table of Contents** page allows easily navigating this manual; click/tap any section line to go to it
- **Bookmarks** allow quickly navigating to any section; click/tap
- **Zoom IN** on pictures by pressing "CTRL and +" at same time on PC, or pinch in on smart devices
- **Zoom OUT** on pictures by pressing "CTRL and -" at same time on PC, or pinch out on smart devices

2.2. Your Kit SKU Number and this Manual

This manual covers installation, testing, and operation of following SKU part numbers

2.2.1. **X3-KIT** (i.e., 102b Train Horn with On-Board Air System)

2.2.2. **X3-OBA** (i.e., On-Board Air System)

NOTE: Illustrations and pictures contained herein may represent only one kit part number. Where critical differences exist between kits (i.e., different parts, orientation, mounting points, etc.), additional text, or necessary graphics are provided to minimize confusion.

Parts list explicitly state kit differences with **(BOLD TEXT)** inside parenthesis, shown below part number.

2.3. Illustration/Photo Details and Orientation

This manual may use digitally created illustrations, and/or actual photos of example vehicle. These graphics may not include exact items found on your vehicle (i.e., electrical wiring, fuel lines, body panels, etc.). Illustrations typically will be missing details and are for clarity to show critical mounting locations and orientation on vehicle.



Throughout manual yellow arrows with text reading "FRONT", may be present over illustrations and pictures. These arrows specify direction toward front of vehicle and provide clarity to how illustration is viewed.



X3-KIT

Installation and Operation Manual

3. Safety First

Read manual thoroughly before starting installation of this kit. Verify you have all parts listed and that you clearly understand this installation procedure. Contact Kleinn technical support for any questions.

Installation of this kit requires **moderate mechanical aptitude**; seek professional help if you're not competent using hand tools in tight uncomfortable spaces, and around possibly rusted and sharp vehicle parts.

Before starting, obtain proper tools required to perform installation correctly, adequate lighting, eye protection, hearing protection for operating train horns, and hand protection to guard against sharp edges and metal burrs, which may be present on kit parts and vehicle parts.

Throughout this manual the following words may be used; be aware of their meaning and application.

CAUTION: means damage could occur to vehicle, or kit parts during, or after installation

WARNING: means injury could occur to you or others, including damage to vehicle, or kit parts

DANGER: means serious injury or death could occur to you or others during installation

End of Section



X3-KIT

Installation and Operation Manual

4. Application Chart

4.1. 100% Direct Bolt-On Vehicle List

X3-KIT is a 100% direct bolt-on aftermarket product for Can-Am vehicles listed in below chart; every effort has been made to verify correct fitment on these vehicles in their factory, non-modified conditions.

MODEL YR	MODEL	DRIVE	ENGINE	BODY	TRIM
2017-2019	MAVERICK X3	ALL	ALL	ALL	ALL**

NOTE: All vehicles listed may require drilling holes for ground wires and installing switches, based on preference of installed switch locations and wire grounding points.

4.2. **Excluded Vehicles

4.2.1. N/A

4.3. Aftermarket Product Compatibility

4.3.1. This kit has been designed to be compatible with following products from leading manufacturers:

- Aftermarket cages that discard OE rearmost bolt-on chassis tubes (i.e., rear deck down tubes)
- Aftermarket front shock tower braces and bulkheads (i.e., S3 PowerSports), which bolt ONLY in front of shocks, or below frame (i.e., cannot attach above sway bar bolts)

4.3.2. **This kit has NOT been designed** to be compatible with any of the following products:

- Exhaust systems or high-performance intake systems, including super/turbo chargers
- Suspension systems (i.e., larger shocks/springs, control arms, sway bar upgrades, etc.)
- Winches
- Oversized tires
- Oversize rear fenders
- Many other systems/parts no listed

NOTE: Review this manual in full before unpacking items and verify correct space and mounting locations exist with your aftermarket product(s). *To install this kit alongside your other aftermarket product(s), modification to included parts, your vehicle, or aftermarket product(s) may be required.*

End of Section



X3-KIT

Installation and Operation Manual

5. Installation Overview

5.1. QUICK INSTALL OUTLINE

For person(s) with experience installing Kleinn bolt-on kits, X3-KIT can be quickly installed following below:

1. Layout and organize all parts on bench
2. Select location for Quick Connect Air Coupler
3. Remove Driver and Passenger Rear Fenders
4. Install Air Tank Brackets (X3-201, 202, 203, & 204)
5. Bench assemble Air Fittings and Air Tubing to Air Tank
6. Install Air Tank
7. Install Air Compressor Brackets (X3-101 & X3-204)
8. Bench assemble Air Compressor Leader Hose Bracket (X3-102) to Air Compressor
9. Install Air Compressor
10. Prepare Front Sway Bar area for Air Horn
11. Install Air Horn Brackets (X3-301 & 302)
12. Install Air Horn
13. Connect air lines and wirings
14. Install Quick Connect Coupler and route Air Tubing
15. Route Wiring, install Relay, and install Horn Button
16. Test system and adjust, as needed
17. Re-install both rear fenders

5.2. Kit Layout and Locations

X3-KIT consists of following sub-systems, located on vehicle, as follows:

ITEM	DESCRIPTION	MOUNTING LOCATION	APPROX. INSTALL TIME
1	6350RC Air Compressor	Rear Frame, Driver Side <i>(behind fender and below rear deck)</i>	1-2 Hours
2	1 Gal. Air Tank	Rear Frame, Passenger Side <i>(behind fender and below rear deck)</i>	1-2 Hours
3	102 Series Dual Horn with Air Solenoid	Front Sway bar Mounts, <i>(directly behind front shocks)</i>	2-4 Hours

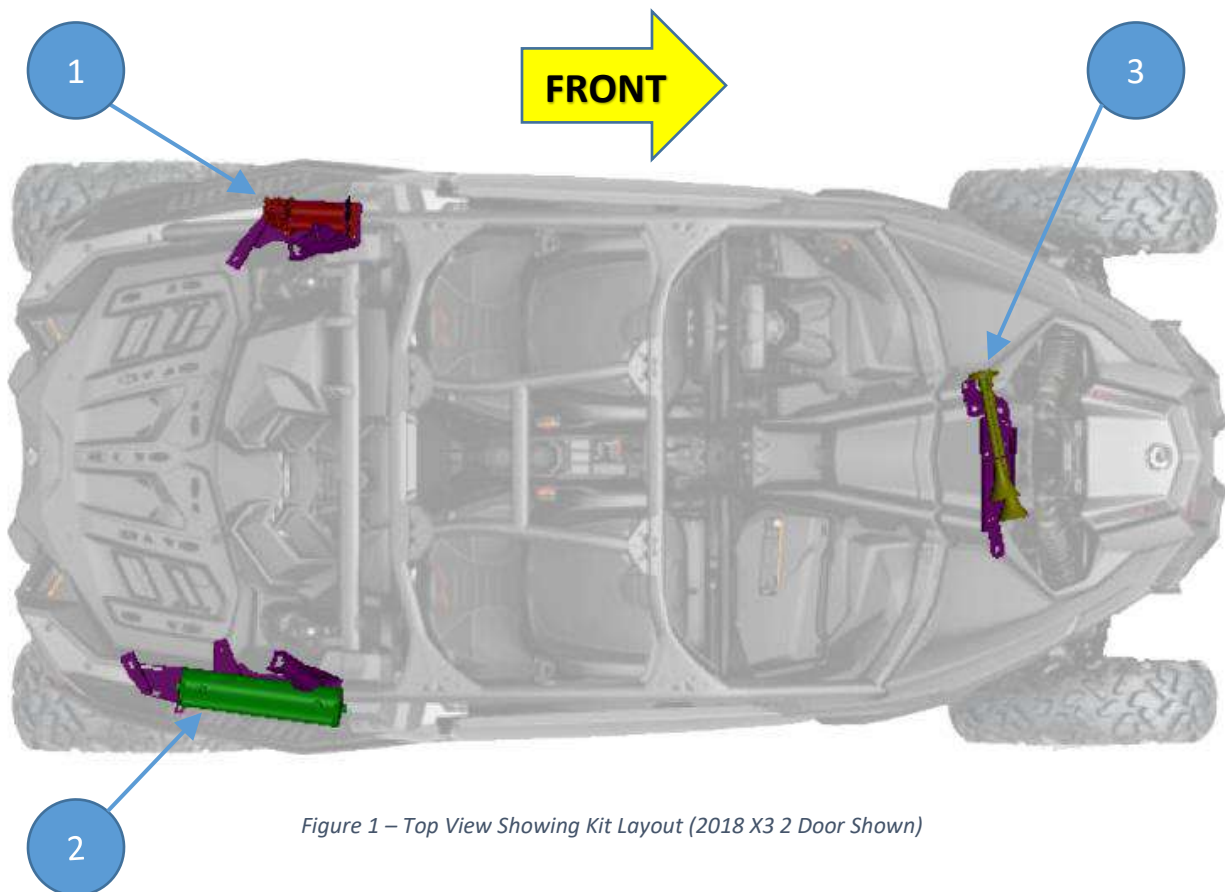

Figure 1 – Top View Showing Kit Layout (2018 X3 2 Door Shown)

5.3. Approximate Installation Time

X3-KIT is a multi-faceted product consisting of multiple mechanical, electrical, and pneumatic components.

For a typical home mechanic, auto enthusiast, or technician installing a Kleinn Bolt-On kit for first time, a professional installation job with setup and testing of final product, is estimated to take:

- **4-8 Hours**



X3-KIT

Installation and Operation Manual

6. List of Tools and Supplies

6.1. Standard Tool List (Required)

- 6.1.1. Basic mechanic's 3/8" drive socket sets with extensions
 - Inch Size Sockets (1/4" – 1" Hex)
 - Metric Size Sockets (6mm – 20mm Hex)
- 6.1.2. Basic mechanic's combination wrenches (box/open-end)
 - Inch Size Wrenches (1/4" – 1" Hex)
 - Metric Size Wrenches (6mm – 20mm Hex)
- 6.1.3. Basic mechanic's screwdriver set (Philips, Flat Head)
- 6.1.4. Torx driver, or socket set (T15-T30)
- 6.1.5. Diagonal Cutter/Wire Cutter Pliers
- 6.1.6. Wire Strippers
- 6.1.7. Wire Terminal Crimpers
- 6.1.8. Slip-Joint Pliers
- 6.1.9. Utility Knife, or Utility Razor blade
- 6.1.10. Magnetic retrieval tool

6.2. Special Tool List (Recommended)

- 6.2.1. 10-100 ft.-lb. torque wrench
- 6.2.2. 20-150 in.-lb. torque wrench
- 6.2.3. Multi-Meter for 12V DC electrical systems, or equivalent
- 6.2.4. 12V DC Test Light, or equivalent
- 6.2.5. Trim Panel Tool, for removing wiring and body clips, when needed

6.3. Shop Consumables List (Recommended)

- 6.3.1. Quality Electrical tape
- 6.3.2. Di-electric grease for electrical connections
- 6.3.3. Heat Shrink tubing for electrical connections
- 6.3.4. Blue Loctite (i.e., Loctite PN 242), or equivalent
- 6.3.5. Sand Paper, or Wire Brushes for installing ground wires
- 6.3.6. Extra plastic zip ties > 6" long
- 6.3.7. Extra NPT sealant (i.e., Kleinn Air Horn Juice, Teflon tape, etc.)
- 6.3.8. Touch-up paint for frame/chassis
- 6.3.9. Typical cleanup supplies

End of Section



X3-KIT

Installation and Operation Manual

7. Parts List



7.1. Before Starting, Review Parts List

Unpackage and organize Kit across a large work area and verify all parts are included, as listed below. Contact Kleinn support if any questions arise.

- 7.1.1. Review pre-packaged Kit items (i.e., K1, K2, etc.)
- 7.1.2. Review Air Fittings and Tubing (i.e., F1, F2, etc.)
- 7.1.3. Review Wiring and Accessories (i.e., E1, E2, etc.)
- 7.1.4. Review Bolt-On Mounting Brackets (i.e., M1, M2, etc.)
- 7.1.5. Review Hardware/Fasteners (i.e., H1, H2, etc.)
- 7.1.6. Familiarize yourself with how parts assemble

7.2. Pre-Packaged Electro-Mechanical Kit Items

NOTE: Items in this section come in their own packages and may include additional items inside package

ITEM	QTY	PART NUMBER	DESCRIPTION	PICTURE
K1	1	6350RC	6350RC Air Compressor Kit, with included hardware, and remote air supply line	
K2	1	6230RT	Air Tank, 4" OD, 1 Gal., 5-Port	
K3	1	102-1	102 Series Air Horn Kit, with included solenoid/valve	



X3-KIT

Installation and Operation Manual

7.3. Air Fittings and Related Items

ITEM	QTY	PART NUMBER	DESCRIPTION	PICTURE
F1	1	2151	1/4" NPT PRESSURE SWITCH	
F2	1	54440	1/4" NPT "T" MANIFOLD, FEMALE	
F3	2	59014	1/4" NPT X 1/4" NPT FEMALE, 90 DEG. ELBOW	
F4	1	52835	1/4" NPT DRAIN VALVE	
F5	1	52175	1/4" NPT, 175 PSI SAFETY VALVE	
F6	1	51414	1/4" NPT X 1/4" TUBE FITTING, STRAIGHT	
F7	2	51414L	1/4" NPT X 1/4" TUBE FITTING, 90 DEG. ELBOW	





X3-KIT

Installation and Operation Manual

F8	1	51414F	1/4" NPT X 1/4" TUBING FEMALE, STRAIGHT <i>(USED ON COMPRESSOR LEADER HOSE END)</i>	
F9	1	25014	1/4" AIR TUBING, 20 FT. LONG <i>(USE 6 FT. FOR COMPRESSOR, 14 FT. FOR AIR HORN)</i>	
F10	1	KLEINN AIR HORN JUICE	THREAD SEALANT FOR NPT FITTINGS	
F11	1	INF-1	INFLATOR KIT, WITH AIR HOSE AND BAG	



7.4. Electrical Small Components and Related Items

ITEM	QTY	PART NUMBER	DESCRIPTION	PICTURE
E1	1	WIRE KIT	FULL WIRE KIT, WITH ELECTRICAL CONNECTORS AND ZIPTIES	
E2	1	1/8" OD X 15FT. LONG	1/8" WIRE LOOM, CORRUGATED AND SPLIT	
E3	1	1/4" OD X 15FT. LONG	1/4" WIRE LOOM, CORRUGATED AND SPLIT	







X3-KIT

Installation and Operation Manual

E4	1	1" OD X 1FT. LONG	1" WIRE LOOM CORRUGATED AND SPLIT	
E5	1	321-W	HORN ROCKER SWITCH, WITH BACKLIT HORN LOGO	

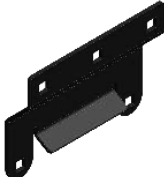

7.5. Bolt-On Mounting Brackets & Special Hardware

ITEM	QTY	PART NUMBER	DESCRIPTION	PICTURE
M1	1	X3-101	COMPRESSOR BRACKET, OUTER HALF, WELDMENT	
M2	1	X3-102	LEADER HOSE ADPATER BRACKET, CUT	
M3	1	X3-201	TANK BRACKET, REAR MOUNT, CUT AND FORMED	
M4	2	X3-202	TANK BRACKET, FRONT-INNER HALF, CUT AND FORMED	
M5	1	X3-203	TANK BRACKET, FRONT-OUTER HALF, WELDMENT	





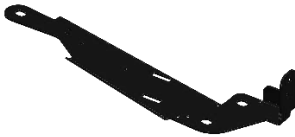

X3-KIT

Installation and Operation Manual

M6	4	X3-204	SPACER, BRACKET HALF, MACHINED	
M7	1	X3-301	HORN BRACKET, CUT AND FORMED	
M8	1	X3-302	HORN STABILIZER BRACKET, CUT AND FORMED	

7.6. Hardware, Fasteners and Soft Parts

NOTE: Pictures only indicative, not to scale and may not represent exact item

ITEM	QTY.	PART NUMBER/SIZE	DESCRIPTION	PICTURE
H1	2	1/4"-20 X 1"	SQUARE NECK BOLT, GRADE 2, ZINC-PLATED	
H2	2	1/4" ID X 0.63" OD	FLAT WASHER, SAE, ZINC-PLATED	
H3	2	1/4"	LOCK WASHER, SPLIT, ZINC-PLATED	
H4	2	1/4"-20	HEX NUT, GRADE 2, ZINC-PLATED	



X3-KIT

Installation and Operation Manual

H5	12	5/16"-18 X 1.00" LONG	SQUARE NECK BOLT, GRADE 2, ZINC-PLATED	
H6	4	5/16"-18 X 2.50" LONG	SQUARE NECK BOLT, GRADE 2, ZINC-PLATED	
H7	4	5/16" ID X 0.88" OD	FLAT WASHER, USS, ZINC- PLATED	
H8	12	5/16" ID X 0.69" OD	FLAT WASHER, SAE, ZINC- PLATED	
H9	16	5/16"	LOCK WASHER, SPLIT, ZINC- PLATED	
H10	16	5/16"-18	HEX NUT, GRADE 2, ZINC- PLATED	
H11	5	M6 X 1 X 20MM LONG	BUTTON HEAD TORX SCREW, BLACK-OXIDE	
H12	2	M6 X 1 X 18MM LONG	COUPLING NUT, CLASS 8, ZINC- PLATED	
H13	1	M6 X 1MM	NO-SLIP, CLIP-ON BARREL NUT	



X3-KIT

Installation and Operation Manual

H14	2	M5 X 0.8 X 10MM LONG	BUTTON HEAD CAP SCREW, BLACK-OXIDE	
H15	7	1/4" ID X 0.63" OD	FLAT WASHER, SAE, BLACK- OXIDE	
H16	2	M6	LOCK WASHER, SPLIT, BLACK- OXIDE	
H17	1	1 1/16" OD X 1/2" ID X 3/8" WIDTH	PRESS-IN RUBBER GROMMET	
H18	1	1 FT. LONG	RUBBER TRIM (NARROW "U")	

End of Section

8. On-Vehicle Mechanical Assembly Steps

8.1. Plan Location of Quick Connect Air Coupler

- 8.1.1. Before installing Brackets, review how kit installs and decide whether to install coupler to vehicle body, frame, or onto supplied brackets; this facilitates later routing Air Tubing and attaching Coupler.

NOTE: Some installers may choose to directly fasten Quick Connect Coupler to Air Compressor, Air Tank, or Air Horn Brackets by using self-tapping screws or drilling a hole for Coupler itself. Although this is common practice, modification of Brackets in any way voids their warranty.

8.2. Remove Passenger side Rear Fender

- 8.2.1. Remove seven (7) T30 screws from top of fender and corner trim, as shown circled in below figure.
- 8.2.2. After removing screws, remove five (5) accompanying body clips on top of rear fender and two (2) on corner trim.

CAUTION: Use care removing body clips and corner trim; corner trim has a hidden clip on backside. All items removed will be re-used later.



Figure 2 – Passenger Rear Fender Removal (fasteners on top of fender)

- 8.2.3. Remove three (3) additional T30 screws; two (2) located behind passenger door and one behind panel in wheel-well area as shown below. Un-clip wire loom from body panel for ease of moving fender.

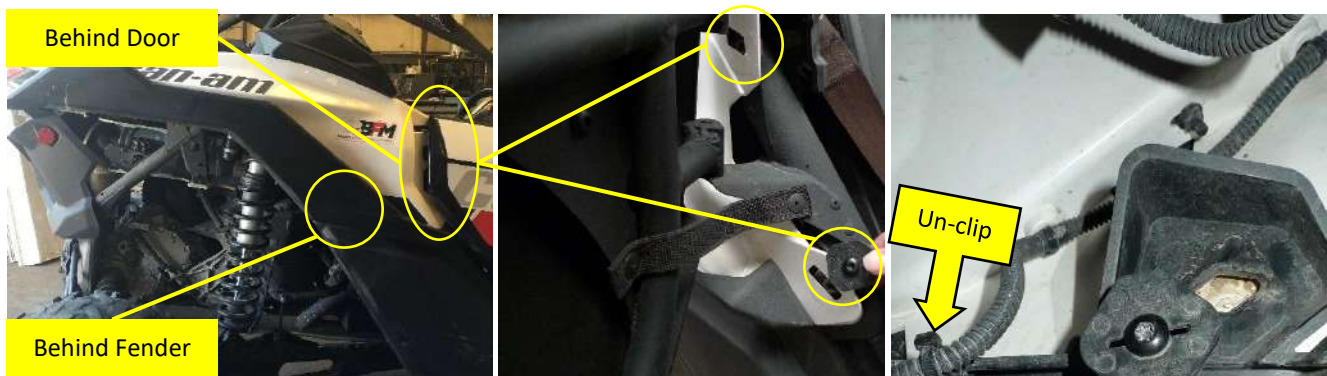

Figure 3 – Passenger Rear Fender Removal (fasteners behind door and fender)

8.2.4. Remove single T15 screw holding rear of fender near inside of brake light, as shown below.



Figure 4 – Passenger Rear Fender Removal (below tail light)

8.2.5. Pull fender outwards from body and rest on tire to reduce stress on Brake Light Wiring, as shown below.



Figure 5 – Passenger Rear Fender Removal (fender resting on tire); Air Tank shown installed

8.3. Remove Driver side Rear Fender

8.3.1. Repeat previous steps for Passenger Fender removal.

8.4. Air Tank Brackets - Installation

8.4.1. Gather Brackets X3-201, X3-202, X3-203 and X3-204 (2)

8.4.2. On passenger side of vehicle, remove two (2) bolts holding rear deck; as shown below. Do not discard large bolt, as it will be re-used. Smaller bolt (i.e., front bolt) will be replaced.

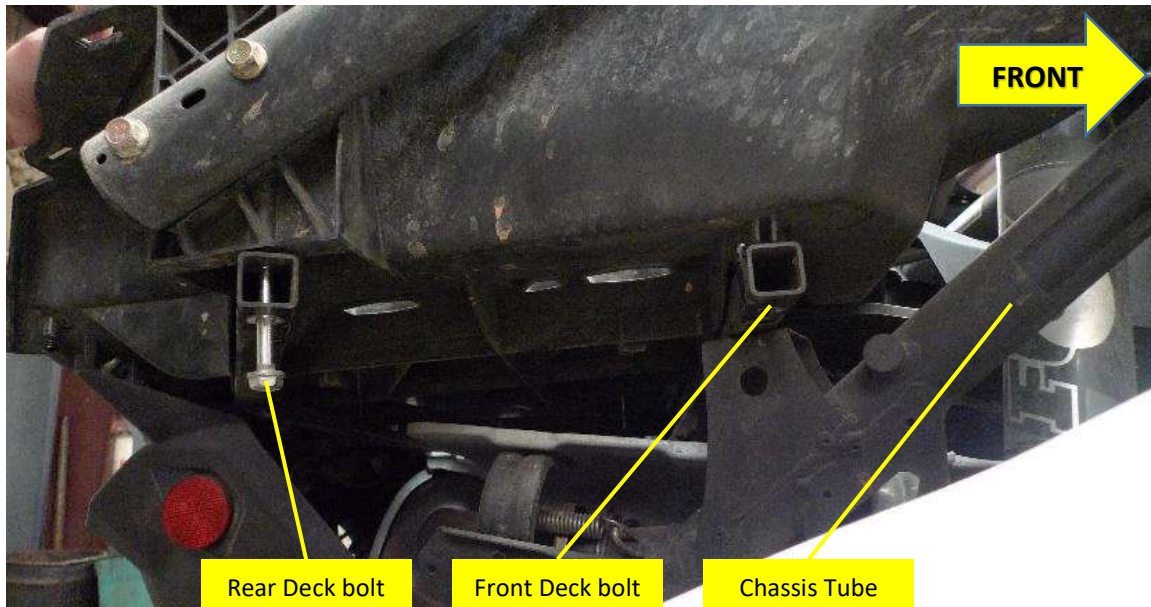

Figure 6 – Air Tank Bracket Mounting Locations (side view)

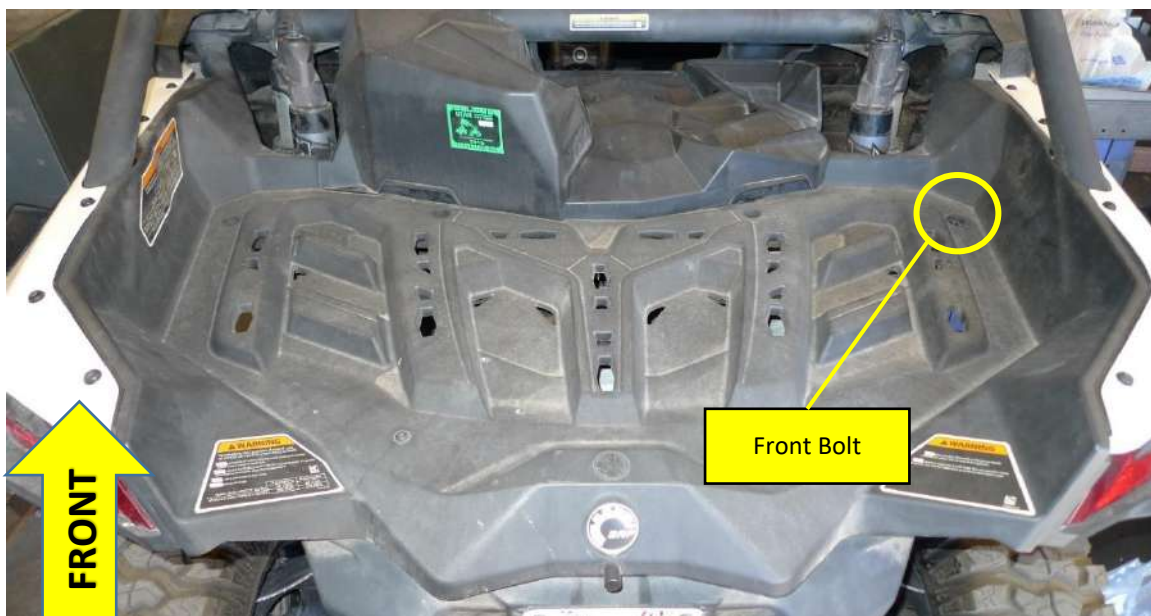

Figure 7 – Air Tank Bracket Mounting Locations (top view)

Installation and Operation Manual

8.4.3. Install Air Tank Bracket (X3-202, 203 & 204) on chassis tube, using hardware #H5, H6, H8, H9 & H10, as shown below. Hand-tighten hardware only, so Bracket can still be rotated and moved along tube.

NOTE: Ensure forward edge of clamp is butted against weld bead on chassis, which increases clearance between back of X3-203 and springs. There should be a minimum ¼" clearance to coil spring.

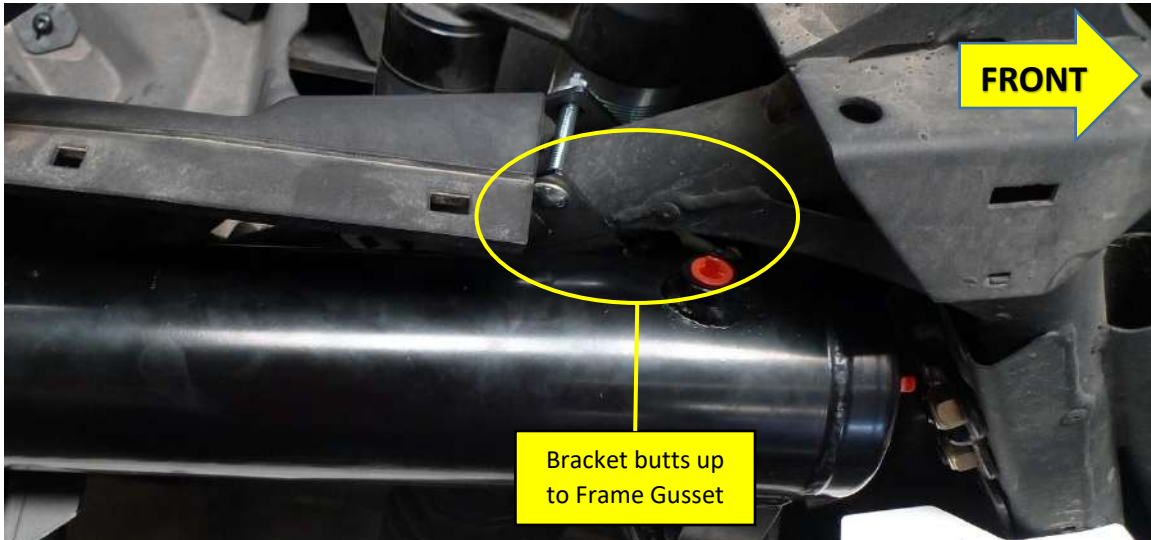

Figure 8 – Front Air Tank Bracket stops at corner Gusset (Shown with Air Tank)

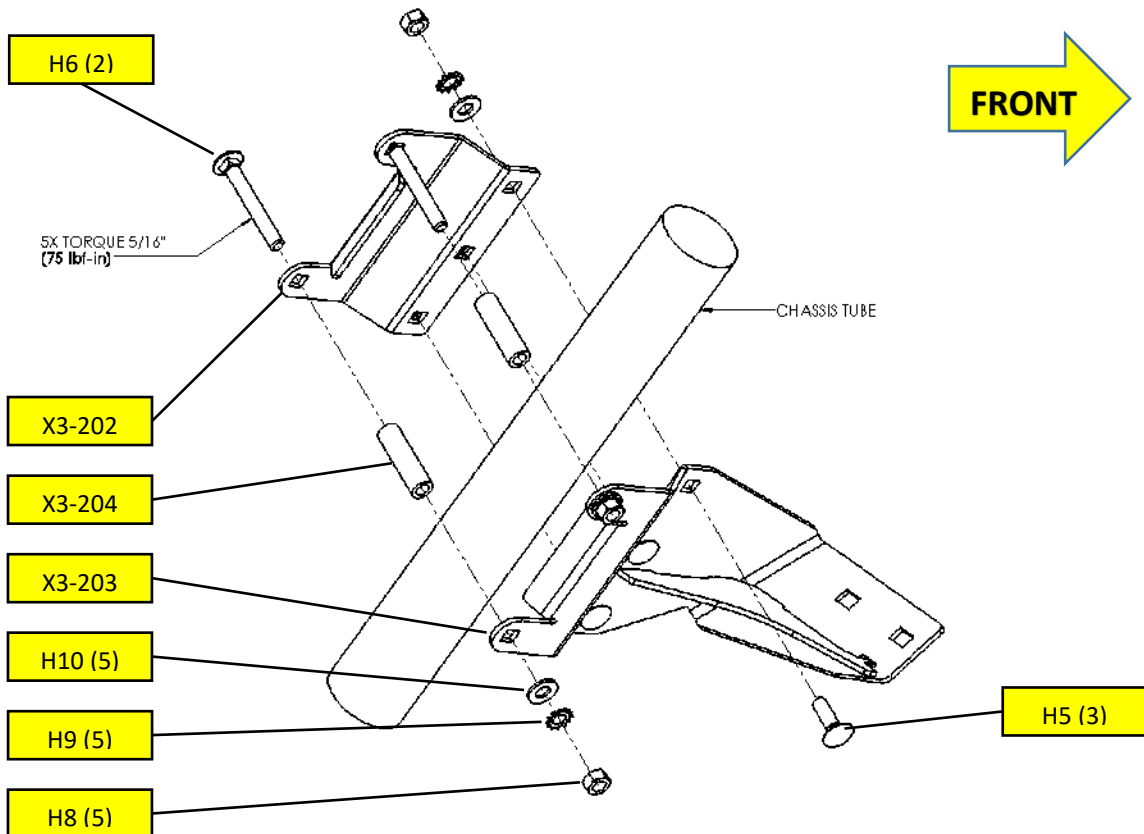

Figure 9 – Installing Front Air Tank Brackets, Exploded View

Installation and Operation Manual

8.4.4. Install Air Tank Bracket X3-201 onto Rear Deck support tubes, using hardware #H11, H12, H13, H15 & H16, as shown below. Hand-tighten hardware only, so Bracket can still be adjusted for Air Tank, as needed.

NOTE: first re-install large rear OE bolt to hold Bracket in place, then use a magnetic tool to hold Coupling Nut and Washer together and insert them into Support Tube.

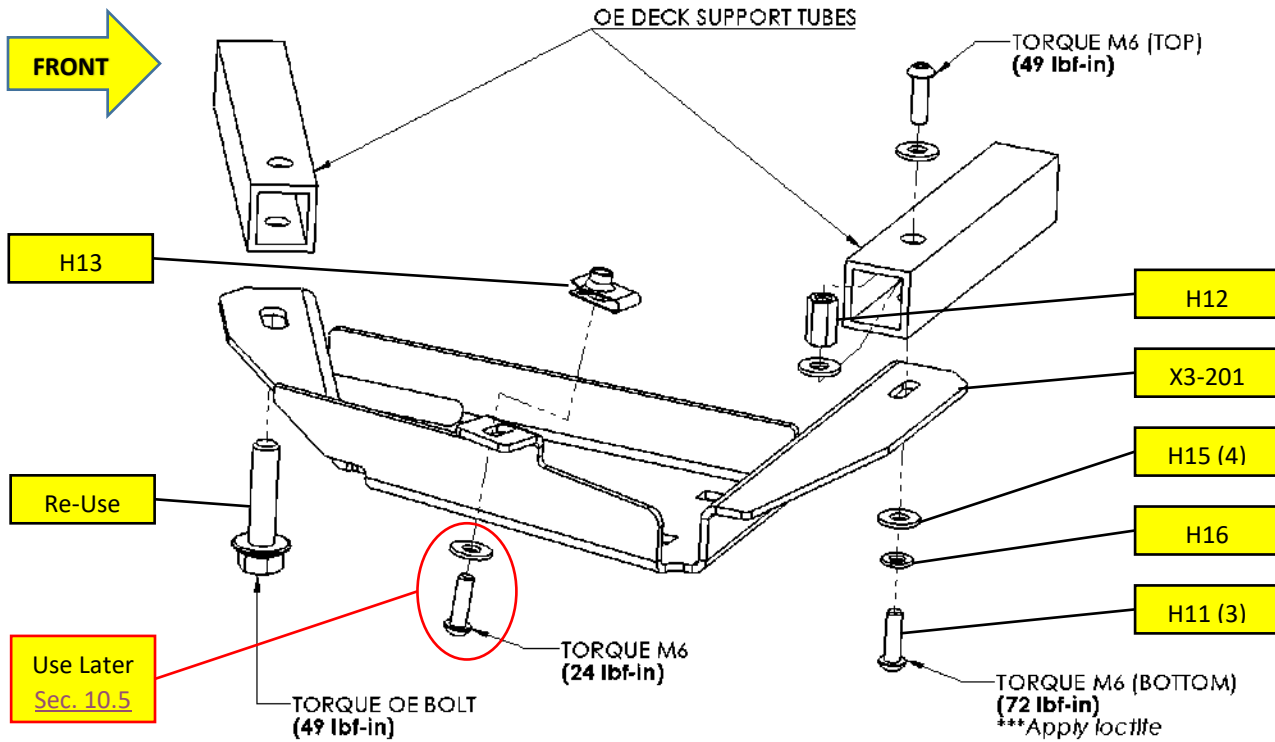

Figure 10 – Installing Rear Air Tank Bracket, Exploded View

8.4.5. Ensure Coupling Nut and Washer are correctly installed inside Tube, as shown below.

NOTE: To hold Coupling Nut while tightening screw, use an SAE standard 10mm open end wrench

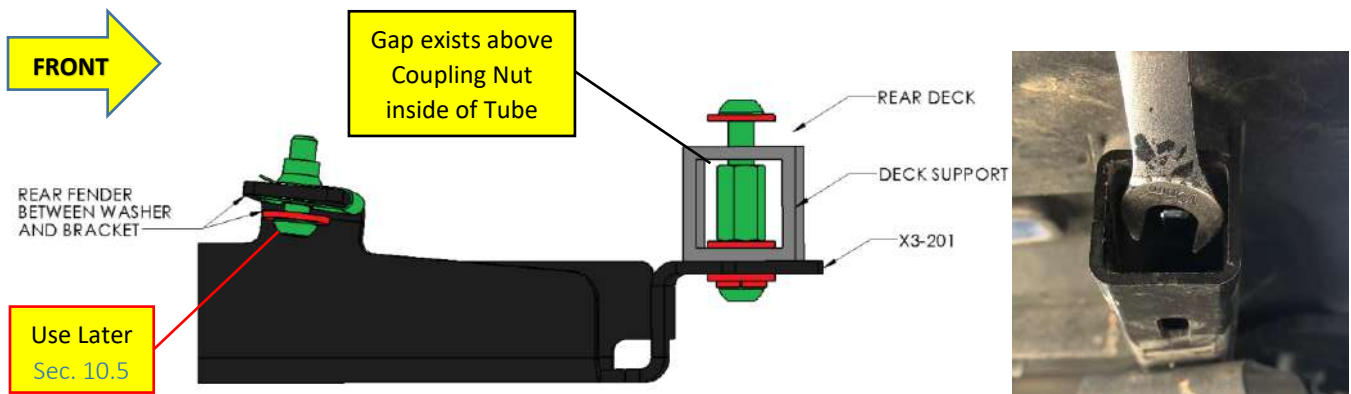

Figure 11 – Installing Rear Air Tank Bracket, Proper Bolt Orientation (partial bracket shown)

8.5. Air Tank Fittings - Bench Assembly

- 8.5.1. Gather all necessary Air Fittings and Air Tank; ensure all threads on fittings and inside ports are clean.
- 8.5.2. Apply two small drops of [Kleinn Air Horn Juice](#) to each male pipe thread.
- 8.5.3. Attach Air Fittings to Air Tank, per below illustration and ensure they are oriented exactly as shown.

[Click Here to View Fittings List](#)

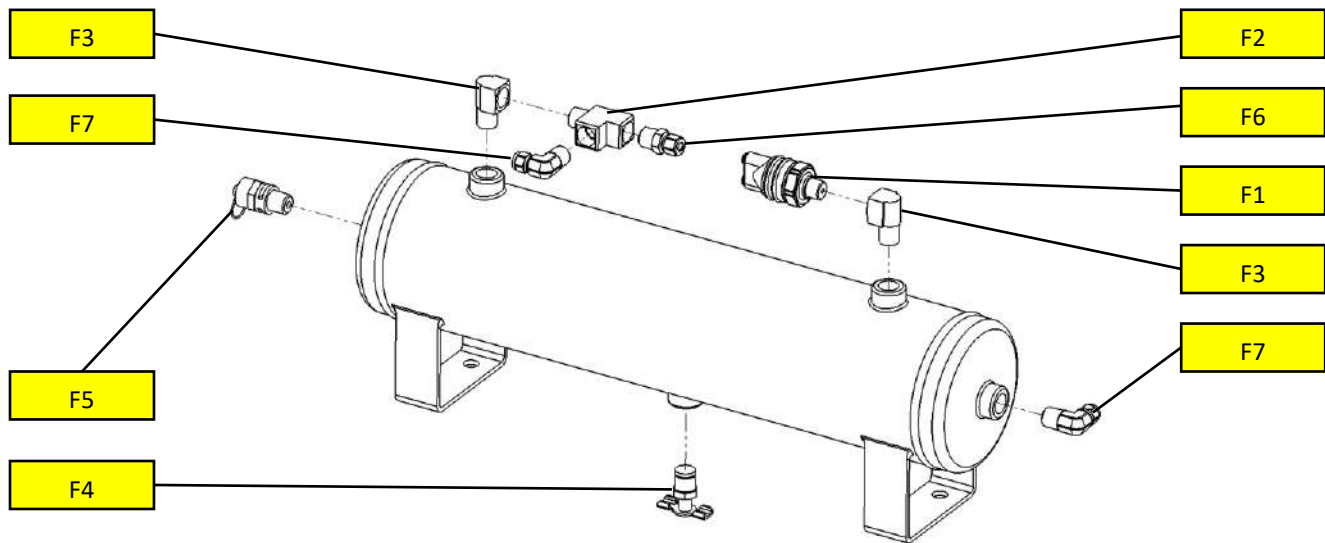

Figure 12 – Air Tank Fittings installed on Air Tank, Exploded View

- 8.5.4. Hand-tighten each fitting, then further tighten 1/4-1/2 turn using proper sized box-end wrench; adjust as necessary to match fitting orientation shown in figure below.
- 8.5.5. Connect a minimum of 6 FT. of supplied 1/4" Air Tubing to front Air Fitting, as shown below. Connections to all Kit components are also listed.

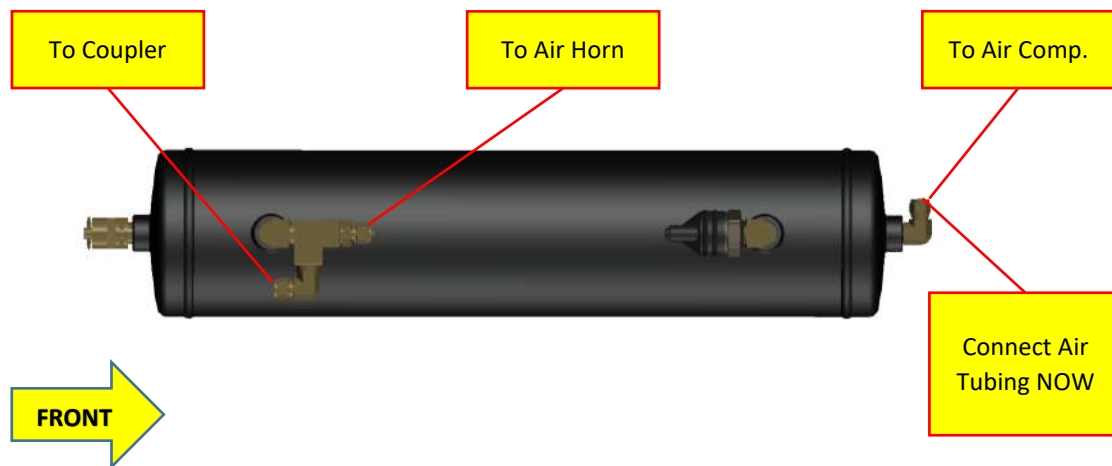

Figure 13 – Air Tank Fittings Orientation (from above vehicle)

8.6. Air Tank - Installation

- 8.6.1. Before starting, ensure at least 6 FT. of supplied $\frac{1}{4}$ " Air Tubing is connected to Air Tank front port, to allow easily routing across rear firewall/chassis and connecting to Air Compressor.
- 8.6.2. Place Air Tank onto Brackets to determine if front Bracket needs to be adjusted (i.e., made level); make any hand adjustments necessary, remove Air Tank, then **final torque front Bracket**, per figure 10 above.
- 8.6.3. Install Air Tank onto Brackets, using [hardware](#) #H5, H7, H9 & H10, as shown below.

NOTE: Position Air Tank and Brackets, as necessary to maintain a minimum $\frac{1}{4}$ " clearance between suspension spring and Bracket. It is ok if Air Tank contacts inner plastic fender, or back of Brackets.

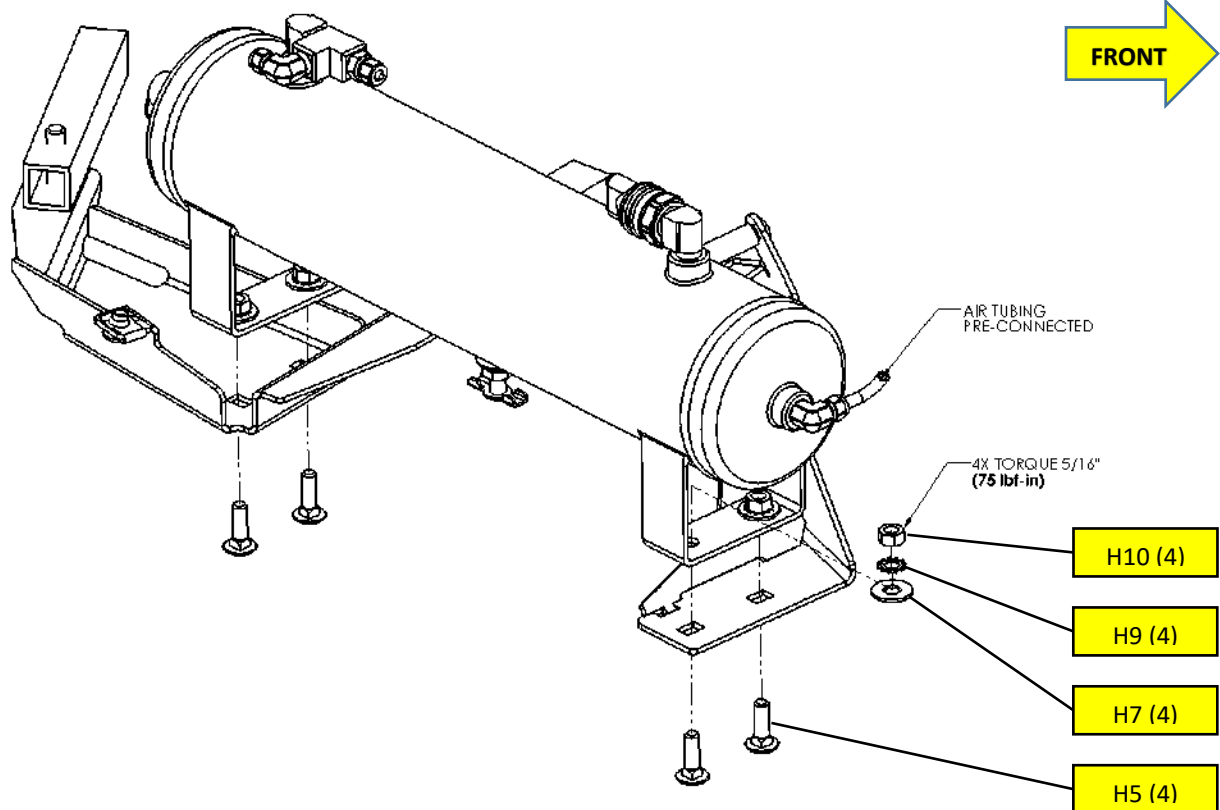

Figure 14 – Installing Air Tank onto Brackets, Exploded View

- 8.6.4. Once Air Tank is properly positioned, **final torque all Air Tank bolts and then rear Bracket bolts**, per figure 11 above.
- 8.6.5. Remainder of Air Tank installation will be completed during electrical wiring and Quick Connect routing.

8.7. Air Compressor Bracket - Installation

8.7.1. Gather Brackets X3-101, X3-202 and X3-204 (2)

8.7.2. On Driver side of vehicle, remove one bolt holding rear deck; as shown below. M6 bolt and nut (i.e., front bolt) will be replaced and may be discarded.

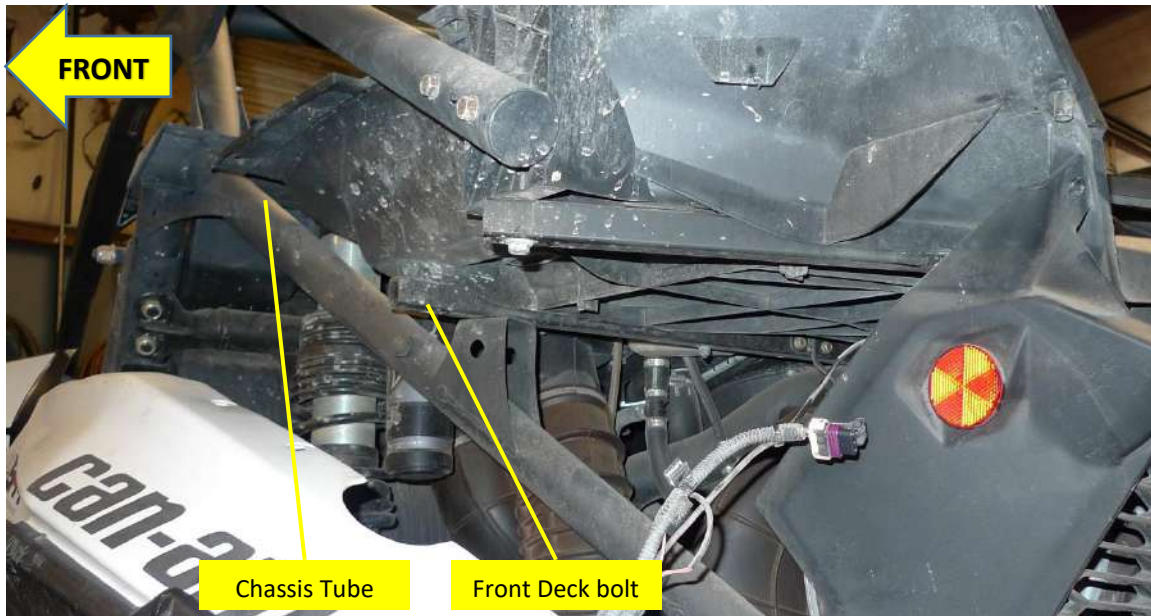

Figure 15 – Air Compressor Bracket Mounting Locations (side view)

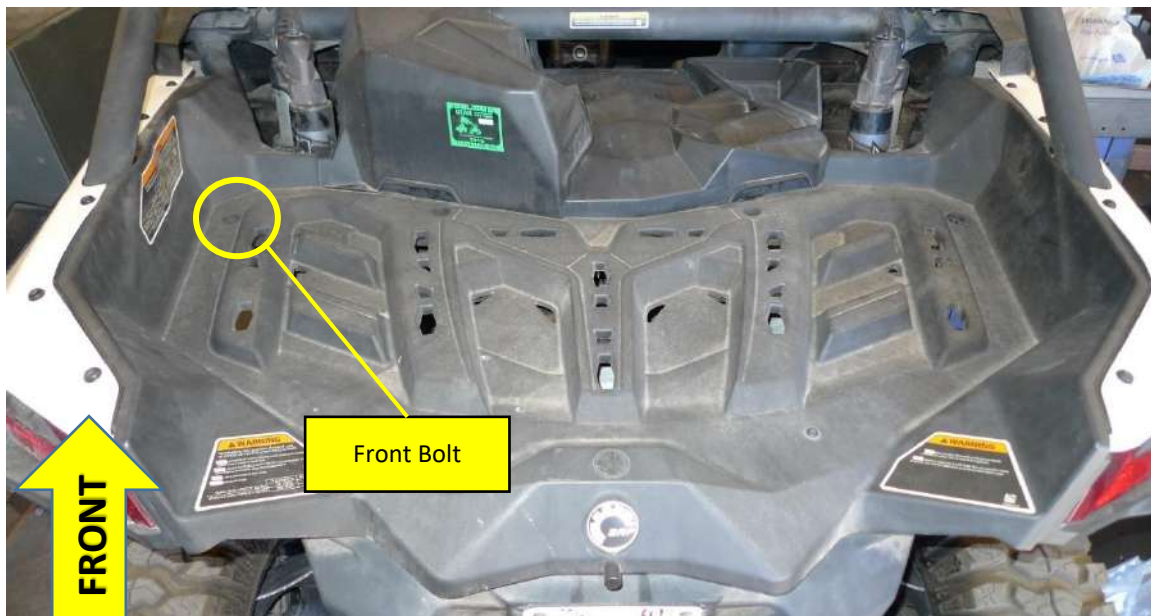

Figure 16 – Air Compressor Bracket Mounting Locations (top view)

Installation and Operation Manual

8.7.3. Install Air Compressor Brackets (X3-101, 202 & 204) on chassis tube, using [hardware](#) #H5, H6, H8, H9, H10, H11, H12, H15 & H16 as shown below. Once Bracket is properly positioned, **final torque all bolts**.

NOTE: Ensure forward edge of clamp is butted against weld bead on chassis, which increases clearance between back of X3-101 and springs. There should be a minimum ¼" clearance to coil spring.

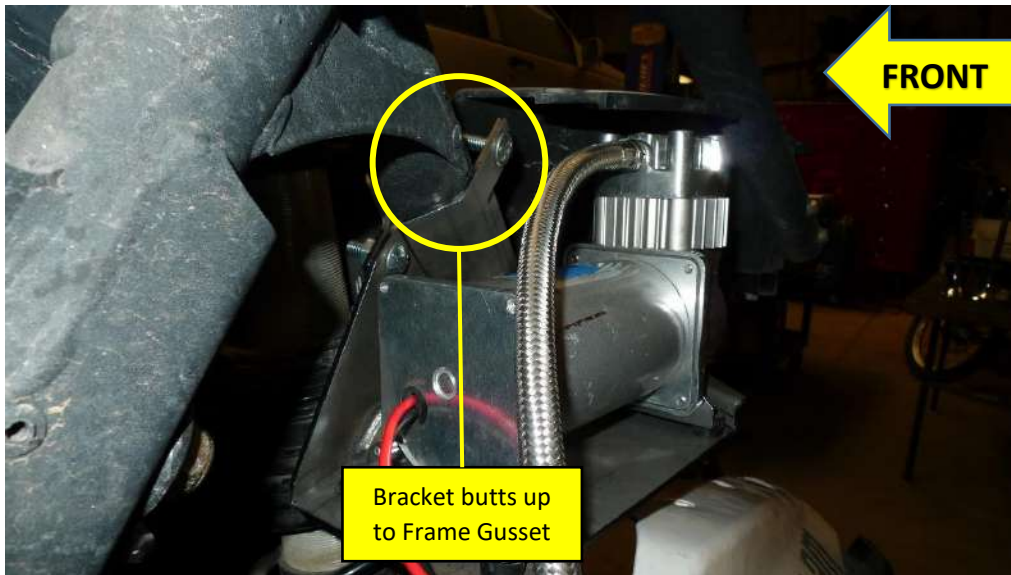

Figure 17 – Front Air Compressor Bracket stops at corner Gusset (Shown with Air Compressor)

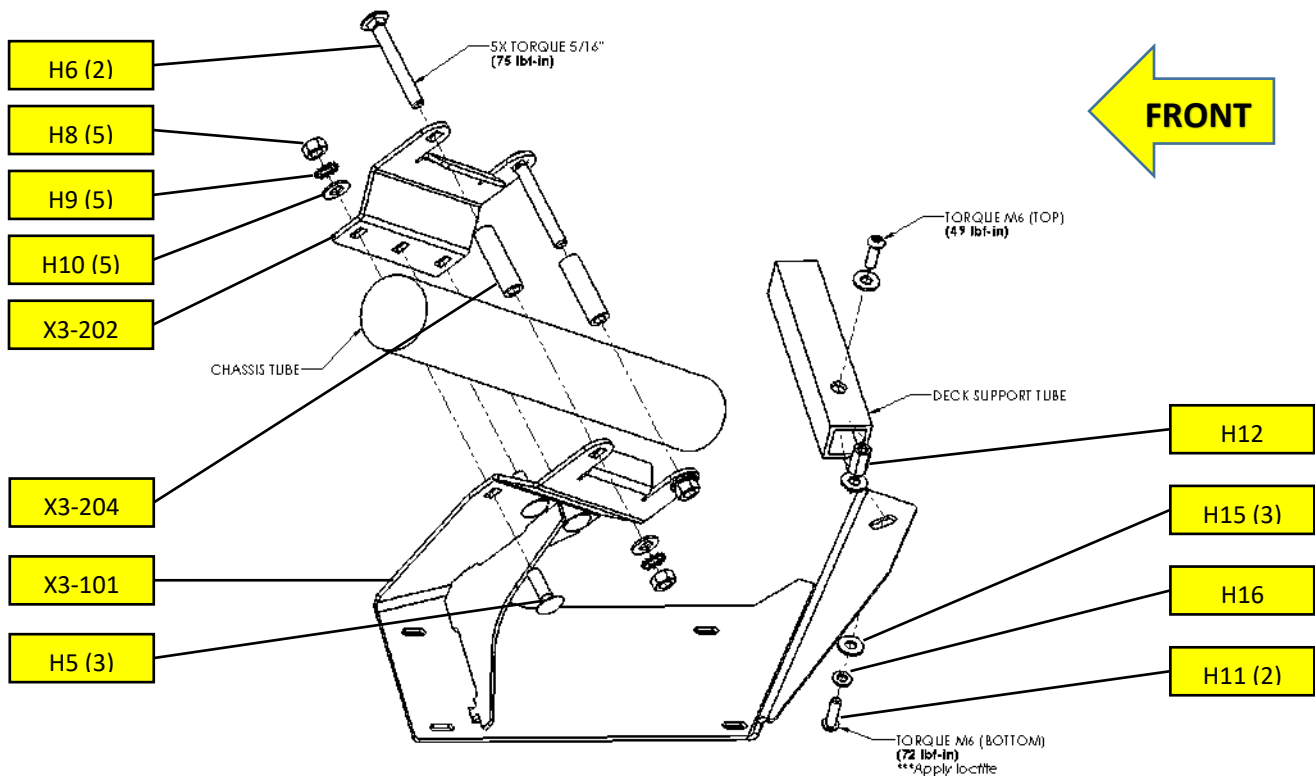

Figure 18 – Installing Air Compressor Bracket, Exploded View

8.8. Air Compressor - Installation

- 8.8.1. Route 1/4" air tubing connected to front of Air Tank across back of firewall, or above chassis, as desired and secure using supplied zip ties. There should be 12 inches of excess tubing sticking out of Driver's side to manipulate and connect to Air Compressor

WARNING: Route plastic tubing distant from heat sources; tubing should never exceed 150 deg F while in use, as tubing can rupture under 150 psi compressed air and cause harm, or injury.

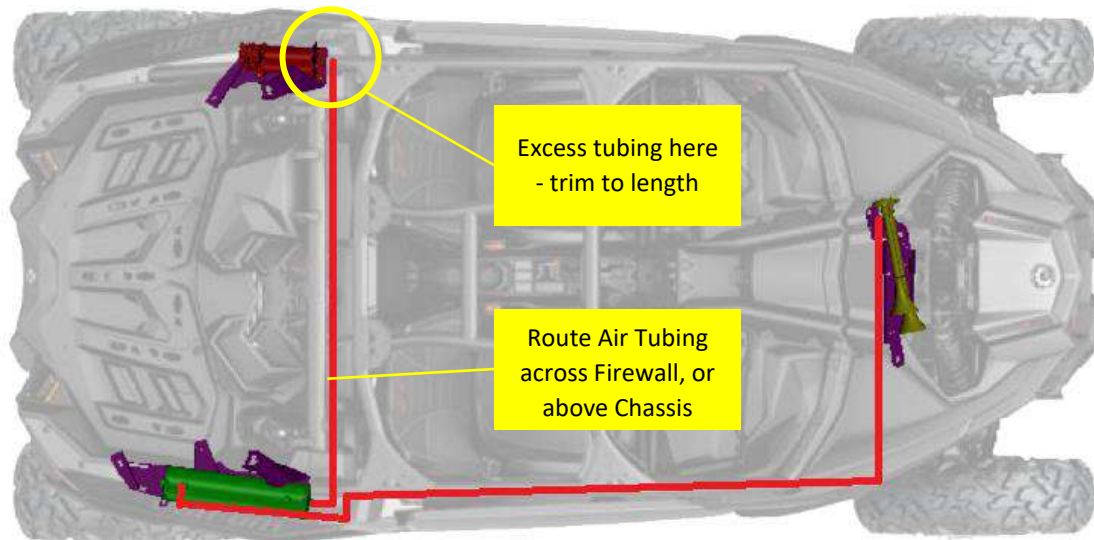

Figure 19 – Air Tubing Route from Air Compressor to Air Tank

- 8.8.2. On a bench, install Air Compressor Leader Hose Adapter Bracket (X3-102) on to back of Compressor and zip tie hose, as shown below. Use a razor blade, or scissors to cut Rubber Grommet in half. Apply adequate Kleinn Air Horn Juice to end of Leader Hose when installing Air Fitting (F8).

CAUTION: It is not recommended to attempt to remove Leader Hose from Compressor and create a single run of 1/4" Air Tubing. Leader Hose removal may permanently damage threads in Compressor.

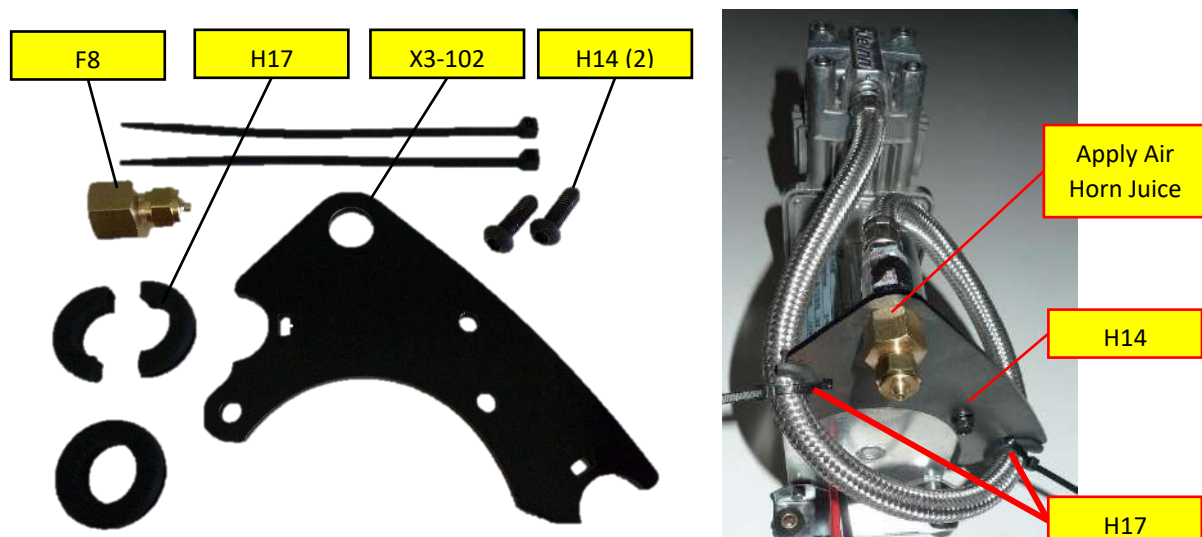

Figure 20 – Installing Air Compressor Leader Hose Adapter Bracket

Installation and Operation Manual

8.8.3. Install Air Compressor on to X3-101 Bracket using hardware included inside Compressor packaging, as shown below. **Final torque all bolts.** Connect previously routed 1/4" Air Tubing to Leader Hose end.

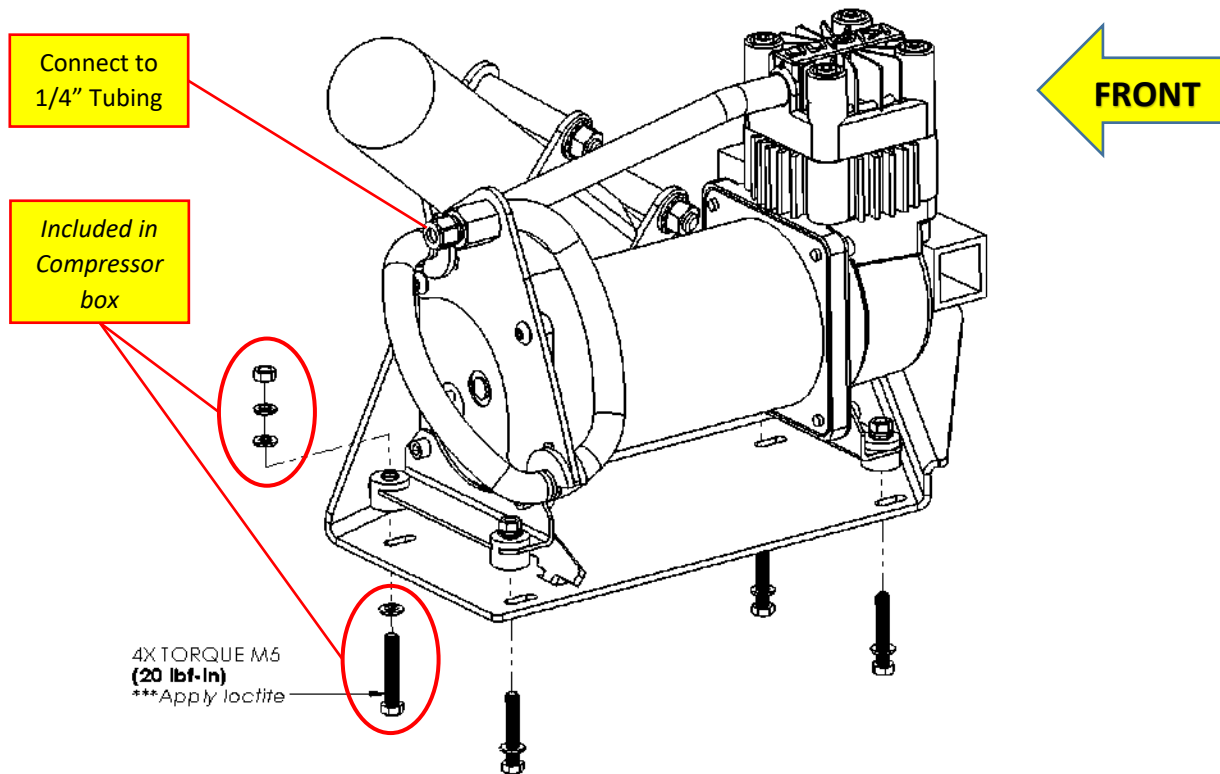

Figure 21 – Installing Air Compressor onto Bracket; Exploded View

8.8.4. Install Air Compressor Air Filter onto end of Compressor, per included directions in Compressor package.

NOTE: if desired, select a dry location with less exposure to dust, water and mud, then route remote Air Compressor Filter and connect to end of Compressor.

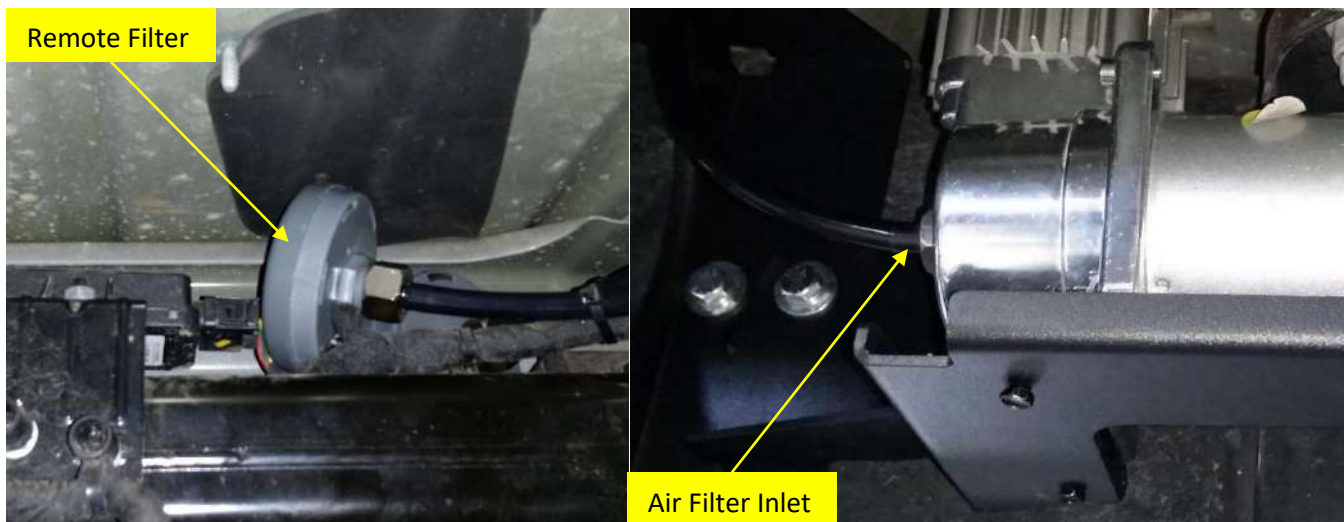

Figure 22 – Air Compressor Filter Remote Tubing shown attached (example vehicle)

8.9. Air Horn - Installation

- 8.9.1. Disassemble Trumpets from Air Horn Driver (item 3 in below picture), by grasping Trumpet throats with hand and twisting counter-clockwise; it may be necessary to clamp Air Horn Driver. Air Horn should be separated into three components, as shown below.

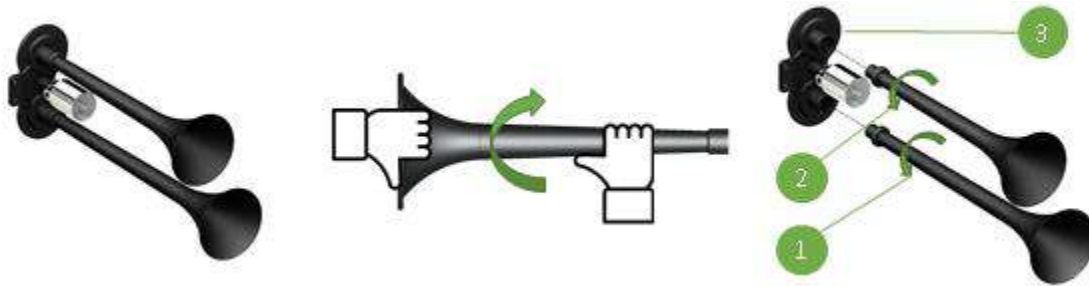

Figure 23 – Disassembly of Air Horn by Separating Trumpets

- 8.9.2. Gather X3-301 Horn Bracket, hardware H5 (2), and a 4" long piece of masking tape, or similar and temporarily tape carriage bolts to bottom of Bracket, as shown below; threads should be sticking up.

NOTE: This step is necessary, as space constraints near Sway Bar make it difficult to insert bolts with Bracket in place. Apply tape long enough that it can be easily removed after installation.

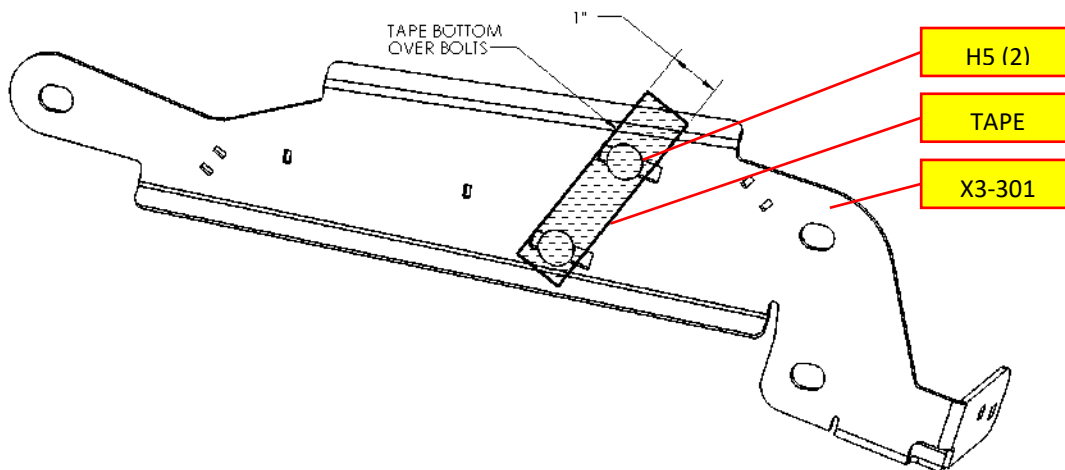

Figure 24 – Carriage Bolts temporarily taped in place on Horn Bracket

- 8.9.3. Gather X3-302 and Rubber U-Trim (hardware_H18), cut trim and install into holes, as shown below.

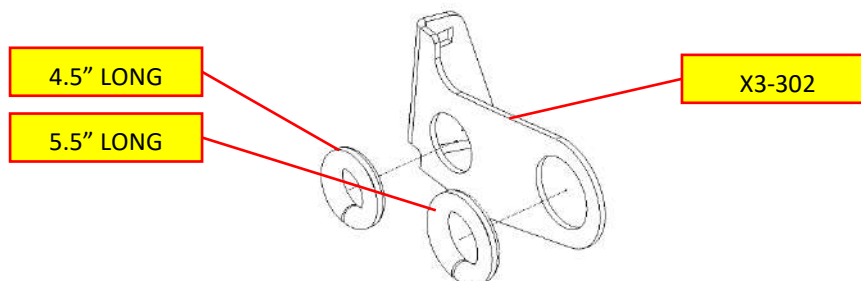

Figure 25 – X3-302 with Rubber U-Trim installed, exploded view

Installation and Operation Manual

8.9.4. Remove three (3) M12 OE bolts that hold front sway bar and remove small T30 bolt holding Brake Line next to firewall, as shown below. Use care removing fasteners, as they will be re-used.

NOTE: Removal of both front wheels will facilitate installation; however, if front suspension is fully extended (i.e., vehicle supported in center with no weight on suspension), the coil springs will be closer to Horn Trumpets, which increases difficulty installing Air Horn.

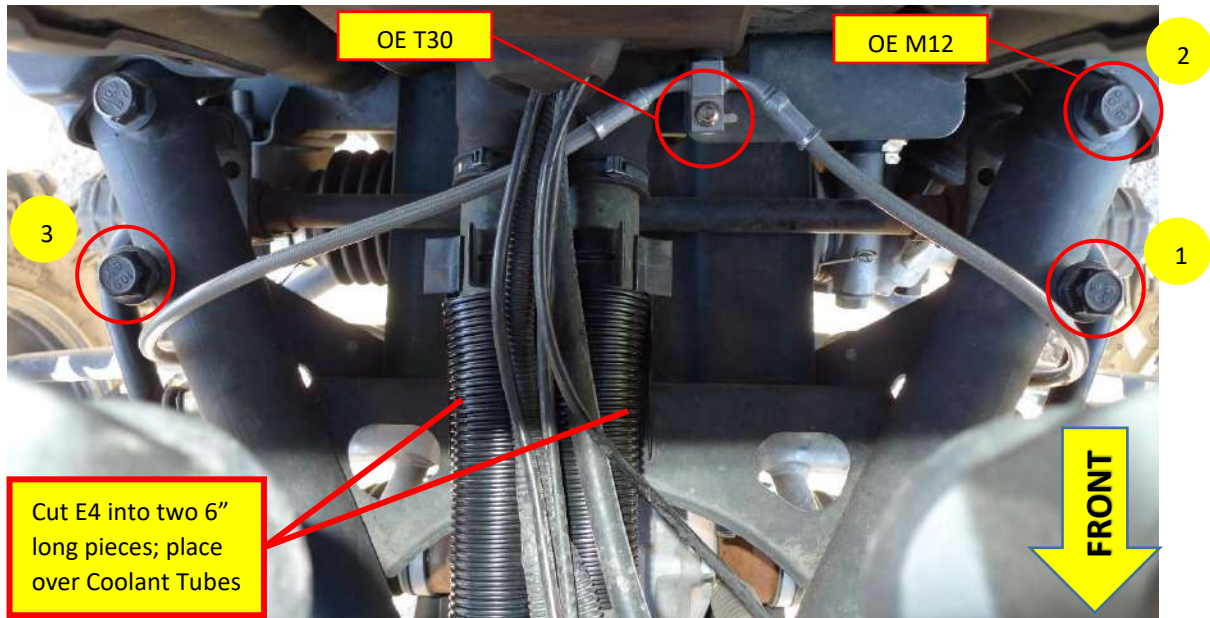

Figure 26 – Sway Bar Bolts to remove and Brake Line Bolt (looking from above)

8.9.5. Cut supplied large corrugated wire loom (E4) into two 6” long pieces and fit over Coolant Tubes, as shown in figure above. Re-adjust loom position as necessary, to provide protection from Bracket touching.

8.9.6. Install X3-301 by pulling upwards on Brake Lines and sliding Bracket underneath, but above Coolant Tubes, as shown below. Use supplied Zip-ties and gently secure Brake Lines, Coolant Tubing, and Wiring to Bracket using small square slots. Zip-ties will be tightened later. **Re-install and torque T30 Bolt.**

NOTE: On vehicles equipped with “Smart-Lok”[®] locking front differential, disconnect vacuum/vent line to differential, if necessary and route above Bracket, then re-connect to front differential.

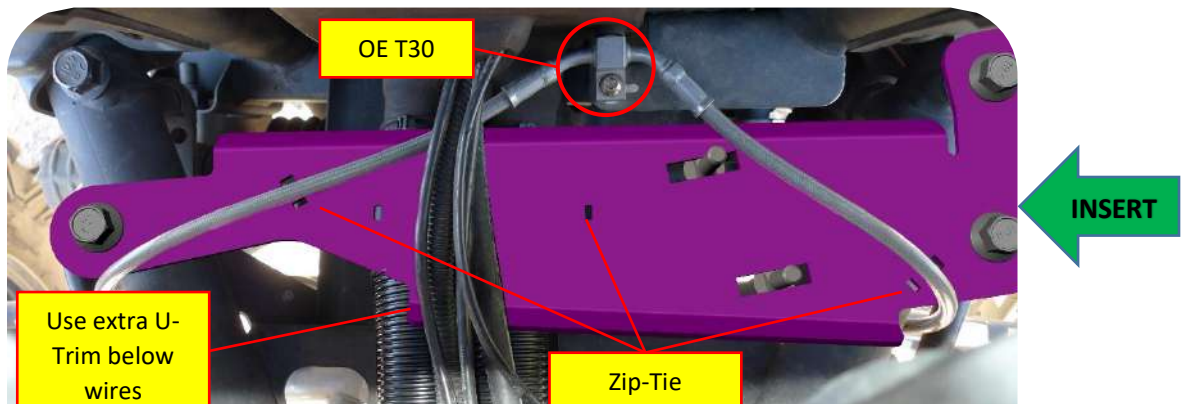

Figure 27 – Air Horn Bracket Installed below Brake Lines

Installation and Operation Manual

8.9.7. Install X3-302 Trumpet Support Clamp and Insert Trumpets, using hardware H8, H9 & H10. Loosely tighten hardware, so X3-302 can still be positioned. Once hardware is installed, remove tape holding bottom side of carriage bolts to Bracket.

3X APPLY ZIP TIES

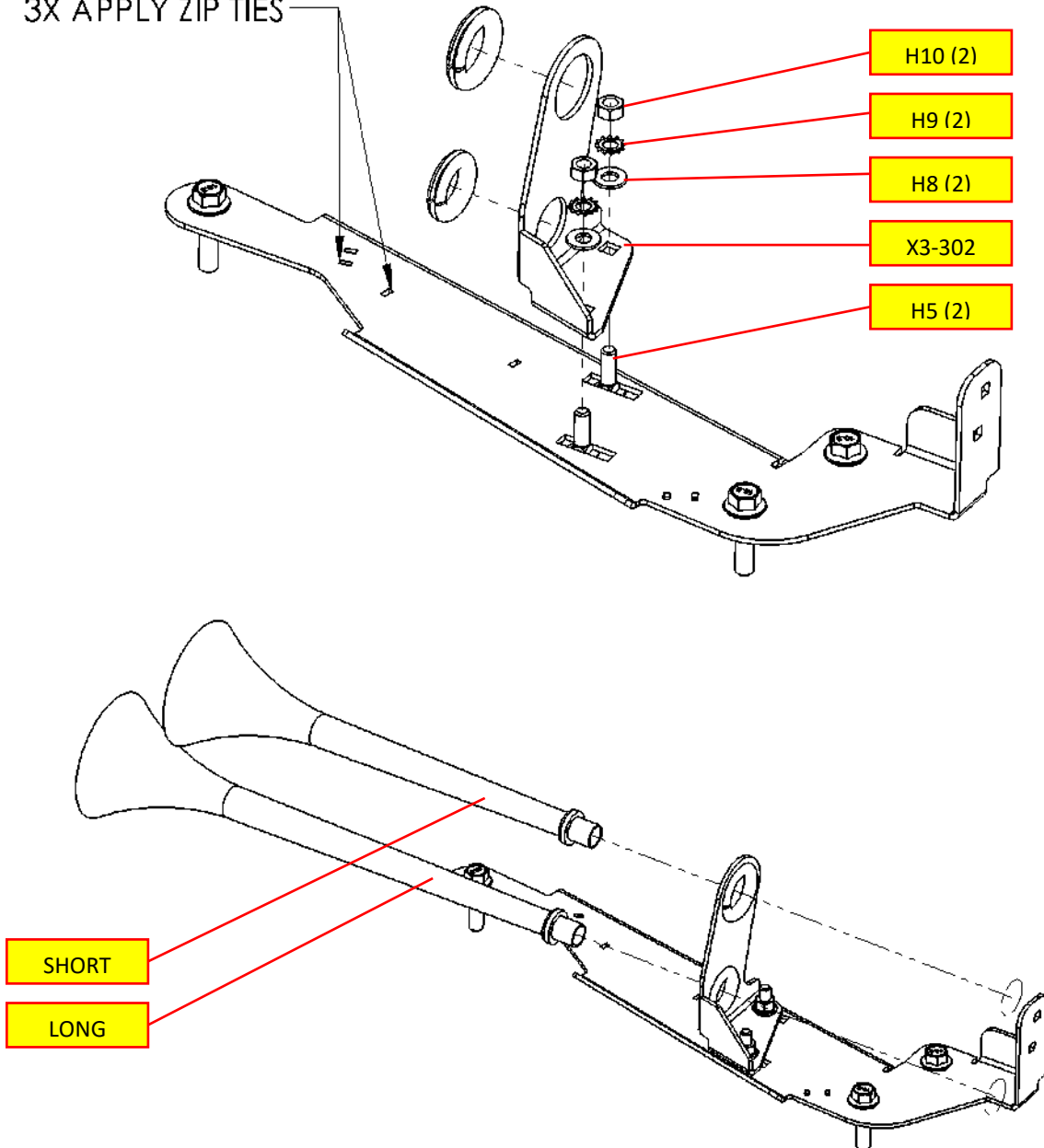

Figure 28 – Installing Trumpet Support Clamp and Trumpets, Exploded View

Installation and Operation Manual

8.9.8. On bench, connect remaining amount of supplied 1/4" Air Tubing to Air Fitting on Air Horn Solenoid, then install Air Horn Driver to Bracket using hardware H1, H1, H3 & H4. Loosely tighten hardware, as shown below. Route 1/4" Air Tubing across Bracket, as desired.

NOTE: It may be necessary to reconnect Trumpets to Air Horn Driver before installing hardware.

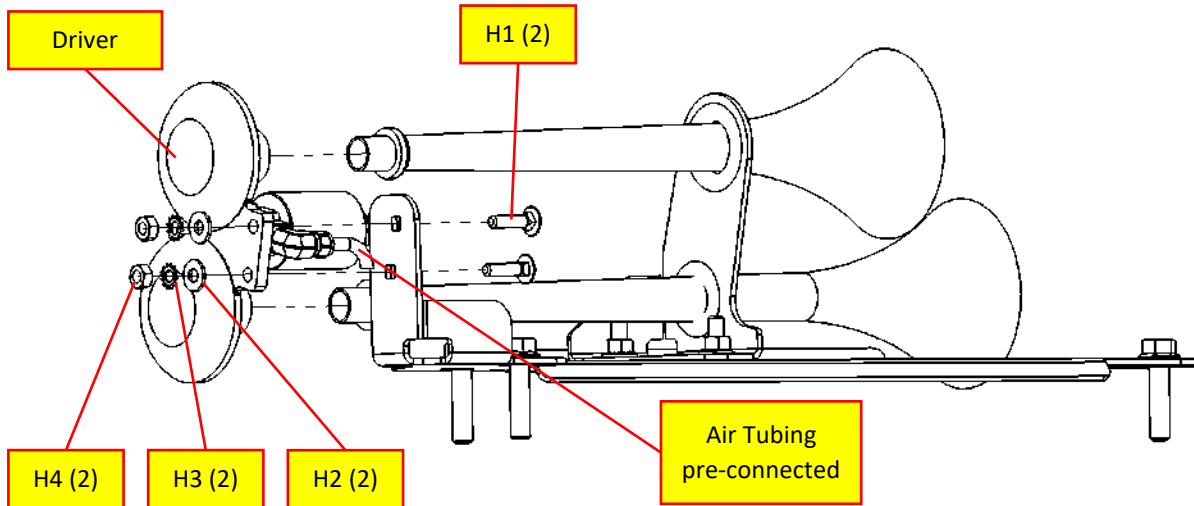

Figure 29 – Installing Air Horn Driver with Tubing attached, Exploded View

8.9.9. With Trumpets and Air Horn Driver connected, **final torque all fasteners**, as shown per order below.

NOTE: position/slide X3-301 Bracket, as necessary to ensure maximum clearance around springs.

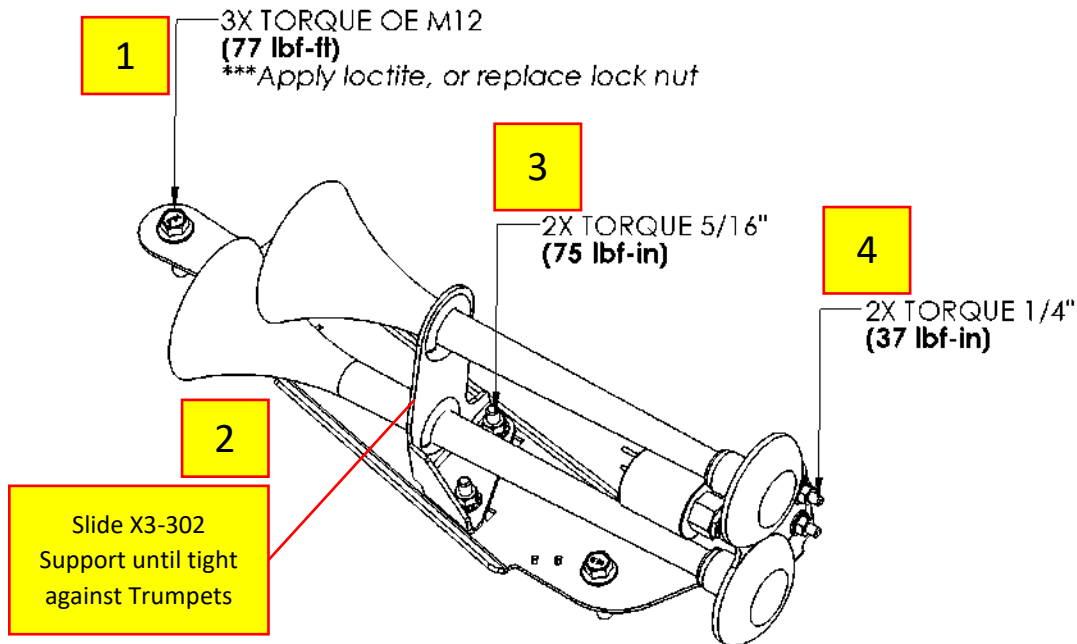

Figure 30 – Final tightening of Air Horn Brackets and Air Horn

Installation and Operation Manual

- 8.9.10. Route Air Tubing back to Air Tank, as desired and safely secure to frame away from heat and sharp edges using zip-ties. Attach to proper port listed in [figure 12 above](#).
- 8.9.11. Final installation of Air Horn should match below pictures.



Figure 31 – Final installation of 102 Air Horn (X3 Turbo R shown)

8.10. Connect Remote Quick Connect Kit to Vehicle

- 8.10.1. Route and attach Quick Connect Coupler Kit to vehicle, as desired using attachment bracket and self-drilling fasteners, supplied in Coupler package
- 8.10.2. Use supplied 1/4" tubing and attach to port shown in [Figure 12 above](#). Some example locations include under rear deck, near front grill, on bumper, on included Bracket, etc.



Figure 32 – Example of Air Coupler Mounted to Bumper

End of Section

9. On-Vehicle Electrical Installation

CAUTION: Follow all recommended safety precautions for working on vehicle's electrical system; consult vehicle owner's manual for further instruction.

9.1. Relay and Fuse Diagram for Air Horn System

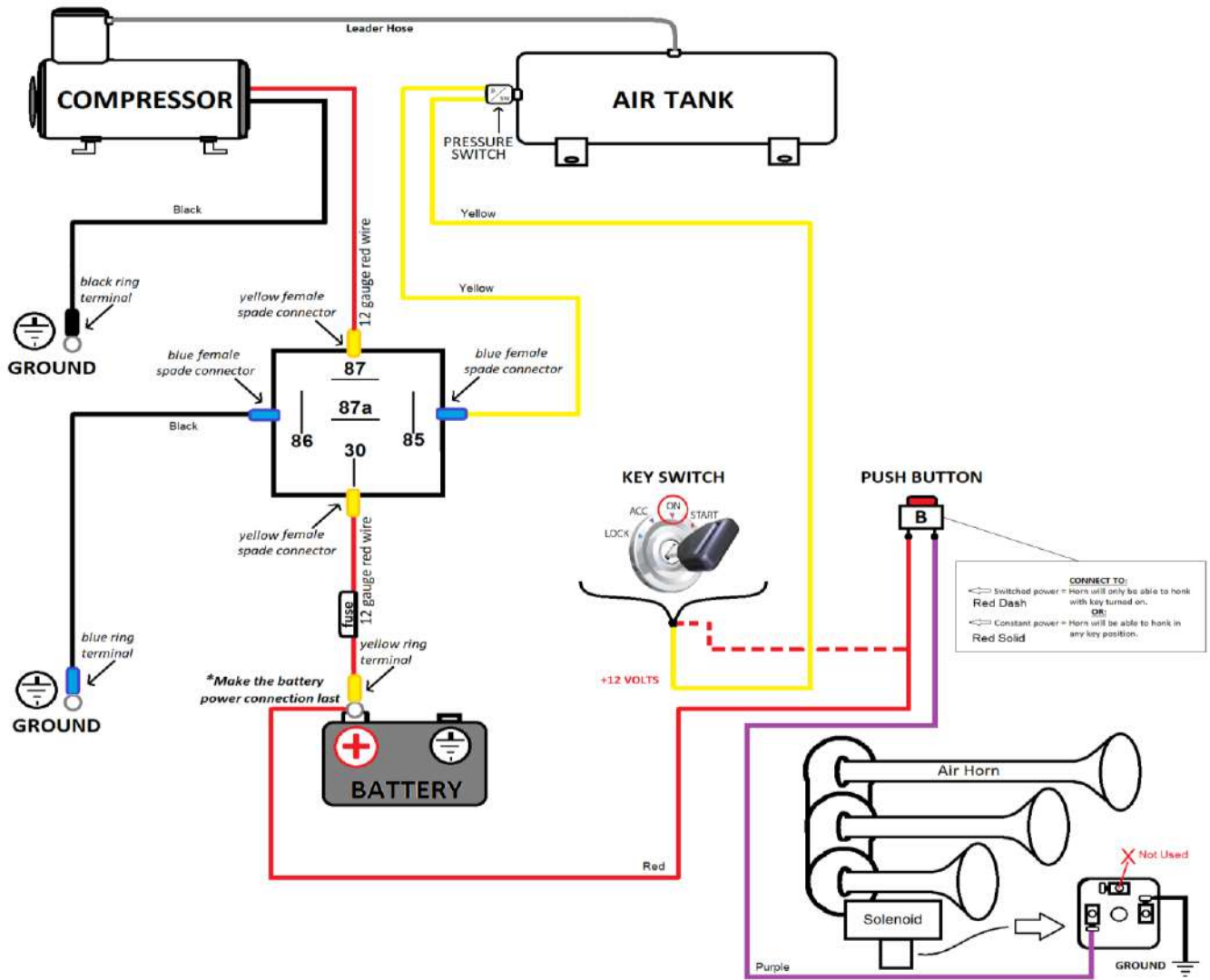

Figure 33 – Suggested Ignition Relay Diagram for Air Horn System

Installation and Operation Manual

9.4.2. Insert all wiring into included wire loom and ensure loom is away from all sharp edges, hot vehicle parts (i.e., exhaust, engine, radiator), and fasten securely to vehicle using zip ties, or equivalent.

NOTE: Do not cut wires to length until 100% sure of length required for final connections.

9.4.3. Install supplied fuse holder on end of power wire by cutting the loop in fuse holder and connecting supplied Ring terminal to one end and Butt connector on other end.

CAUTION: Do not install 30-amp fuse until all electrical connections are final.

9.5. Install Horn Button

9.5.1. It's recommended to install Horn Push Button (E5) in OE location designed for aftermarket switches and accessories, found at center console, as shown below.



Figure 36 – Recommended install location for Air Horn Button

9.5.2. If desired otherwise, find another suitable location that has 1"+ of clearance behind for terminals, then mark location for drilling. Drill a 3/4" hole at location. Route horn button wires to hole then slide push-button retaining nut over wires and connect per wiring diagram. Install push-button into hole and tighten retaining nut securely on backside.

9.6. Connect Air Horn Solenoid(s)

Route wiring, as desired up to Air Horn and connect to Solenoid.

9.7. Pressure Switch

9.7.1. Route wiring, as desired back to Air Tank and connect to Pressure Switch.



X3-KIT

Installation and Operation Manual

10. Initial Testing of Kit

10.1. Reconnect Vehicle Battery(s)

CAUTION: Before connecting vehicle battery(s), verify all wiring is properly connected and no shorts exists. Use of Multi-Meter, or Test Light is recommended to check continuity of all connections.

10.2. Test Air Compressor

- 10.2.1. Turn vehicle ignition to on position and allow compressor to fill Air Tank. Initial fill may take approximately 1.5-3 minutes; Air Compressor should shut off automatically once full pressure is achieved.
- 10.2.2. If compressor runs excessively (i.e., 5 minutes or more), disconnect electrical power to Air Compressor and listen for air leaks in system. Repair any problems and retest; contact Kleinn technical support if problem persists.
- 10.2.3. Inspect all air line connections (i.e., Air Tank fittings, Quick Connect fittings, Air Horn fittings, etc.) for leaks by using a soap and water solution sprayed directly onto fittings
- 10.2.4. System must be pressurized or at least Air Compressor running
- 10.2.5. If an air leak is found:
- 10.2.6. Safely release air pressure from system (i.e., slowly open drain valve)
- 10.2.7. Disassemble leaky connection, re-seal and reinstall fittings as needed

10.3. Test Train Horns

- 10.3.1. Allow Air Compressor to run and shut-off automatically (i.e., Air Tank is full)
- 10.3.2. Verify all tubing and electrical wire is securely fastened to vehicle, brackets, or kit parts; if necessary, use extra zip ties to hold tubing and wire in place
- 10.3.3. Ensure all nearby persons have adequate hearing protection and provide courtesy warning to neighbors or others in vicinity

WARNING: NEVER operate train horns with ears close to trumpets or in an enclosed space without substantial hearing protection (i.e., > Ear Plugs and Ear Muffs) for all persons closer than 100 feet from vehicle. Never operate train horns outdoors when persons are near vehicle without adequate hearing protection.

- 10.3.4. Briefly activate Horns by pressing Horn Button for one (1) second; repeat three (3) times with a short rest period between (i.e., 1-3 seconds)
- 10.3.5. Horns should sound as expected and be loud; [click to listen to example 230 Kit](#)
- 10.3.6. Horn sound/loudness will taper quickly as Air Tank loses pressure
- 10.3.7. Allow Air Compressor to refill tank, if needed and activate Horns for longer three (3) second period to ensure Horns are functioning properly.

10.4. Test Quick Connect Coupler

- 10.4.1. Allow Air Compressor to refill tank, if needed
- 10.4.2. Attach supplied INF-1 inflator kit to Quick Connect Coupler and verify adequate air pressure is available
- 10.4.3. Test fill tires on vehicle, bicycle, etc.
- 10.4.4. Use Air Blow Gun
- 10.4.5. Use Air Impact Gun

10.5. Re-install Rear Fenders

- 10.5.1. After successful testing of entire kit, re-install Passenger and Driver side Rear Fenders in reverse order used in [section 8.2 above](#).
- 10.5.2. Install hardware H11 & H15 through corresponding slot in bottom of Passenger fender into X3-201 Nut H13, as shown in [figure 10 & 11 above](#).

End of Section



X3-KIT

Installation and Operation Manual

11. General Operation of Kit

11.1. Compressor Operation

WARNING: *Never operate Air Compressor above its MAXIMUM PRESSURE RATING (see label on body). Operation exceeding maximum pressure will damage Air Compressor and may result in Dangerous Air System failure.*

- 11.1.1. Air compressor is equipped with an automatic thermal overload protection circuit, designed to protect air compressor from overheating and causing permanent damage.
- 11.1.2. Automatic thermal overload protector will automatically reset after 30 minutes.
- 11.1.3. To prevent discharge of vehicle's battery and for best performance, keep vehicle's engine running while using air compressor for any prolonged use (i.e., filling tires, using air tools, etc.).

11.2. Horn Operation

- 11.2.1. Allow Air Compressor to run until it shuts off automatically (i.e., Air Tank is full), or for at least one minute in between horn activations.
- 11.2.2. Press Horn Button to activate Horns
- 11.2.3. Horn sound/loudness will taper quickly as Air Tank loses pressure.
- 11.2.4. Horns should sound for 3-7 seconds depending on kit and tank size

WARNING: *NEVER operate train horns with ears close to trumpets or in an enclosed space without [substantial hearing protection](#) (i.e., > Ear Plugs and Ear Muffs) for all persons closer than 100 feet from vehicle. Never operate train horns outdoors when persons are near vehicle without adequate hearing protection.*

12. Routine Maintenance

Perform following steps at least once during recommended intervals.

- 12.1. Yearly, or every 12000 miles verify all mounting fasteners are properly torqued; applying witness marks across fasteners and mounting parts is good practice to quickly ensure fasteners have not moved.
- 12.2. Yearly, or every 12000 miles **inspect OE wiring, tubing, cables, etc.** where Kit parts may touch, to **verify no abrasion or rubbing.**
- 12.3. Yearly, or every 12000 miles remove all road grime and mud from mounting brackets and kit parts using clean water from a garden hose; pay special attention to corners where dirt may collect. Touch up all paint chips using automotive grade enamel in either spray, or brush form.

NOTE: High-pressure washers may damage part finishes and *must* be used with care. Do this more frequently if traveling regularly off-road, or in winter climates with road salts.

- 12.4. Yearly, or every 12000 miles check electrical and air fitting connections and wires for abrasion, corrosion, or other damage. Replace damaged components.

NOTE: if system runs continuously or turns on unexpectedly, leaks or intermittent electrical connection may be present.

- 12.5. Monthly, or every 10 hours of compressor run time, drain moisture from air tank using drain valve installed at bottom of tank.

WARNING: *Failure to regularly drain air tank may result in corrosion inside tank and possible failure in tank or air lines, which can suddenly release air pressure causing injury.*

- 12.6. Yearly, or every 12000 miles clean, or replace air compressor air filter element. Replacement frequency depends on operating frequency and conditions of operating environment (i.e., daily use requires more frequent changes).

NOTE: Never lubricate or add any liquids to the included oil-less air compressor