

AT-9208PT
SLIP-ON EXHAUST ASSEMBLY
2017 AND UP CAN-AM MAVERICK X3

MBRP
P O W E R S P O R T S

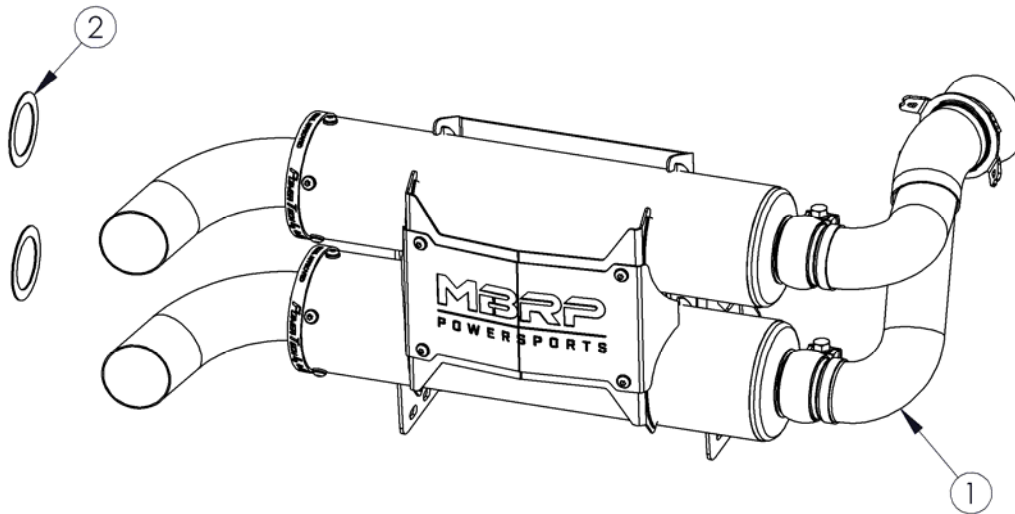

1. MUFFLER ASSEMBLY
2. RING INSERT [2 PCS]

PLEASE READ BEFORE STARTING INSTALLATION

While MBRP Inc. has made every effort to ensure that all components of this system are of superior quality and properly packaged, it is the installer's responsibility to ensure the following before removal of the factory exhaust:

- that ALL components shown above are present.
- that ALL mating components fit together.
- that there are no damaged components.
- that the system you have purchased is appropriate for your year and model of SXS.
- that the system will not interfere with any modifications previously installed or planned.
- that you have read and understand these instructions.

If you have any questions or are uncertain about any aspect of the installation of this system to your SXS please contact your dealer before commencing installation.

Removal of Stock Exhaust:



Figure 1



Figure 2



Figure 3



Figure 4



Figure 5



1. Remove the rear fascia assembly by removing the five screws securing it. **Refer to Figure 1.**

2. Remove the two (2) bolts and nuts securing the driver-side bracket of the stock muffler. Keep the hardware as it will be reused.

3. Remove the two (2) nuts from the bolts securing the passenger-side bracket of the stock muffler. Leave the bolts in place to support the muffler. Retain the hardware as it will be reused. **Refer to Figure 2.**

3. Remove the factory springs (4) from the muffler inlet; they will be reused for the installation. **Refer to Figure 3.**

4. Remove the two (2) bolts from the passenger-side bracket of the stock muffler and remove the muffler.

Installation of MBRP Exhaust:

*If necessary, the position of the muffler assembly can be adjusted (up/down) by loosening the two (2) nuts on the back of the mounting bracket and retightening them in the desired location.

1. Place the **Muffler Assembly** into position and insert the previously-removed long stock bolts through the passenger-side holes of the mounting bracket and into the stock mounts, loosely securing them using the stock nuts. **Refer to Figure 4.**

2. With the passenger-side mounting hardware in place, insert the driver-side bolts through the mounting holes and loosely secure them with the stock nuts to hold the **Muffler Assembly** in place.

3. Place the **Muffler Assembly** inlet into position over the stock exhaust gasket and secure it using the four (4) springs that were previously removed. **Refer to Figure 5.**
*If necessary, the position of the mufflers can be adjusted (left/right) by removing the logo plate and loosening the two (2) 8mm bolts holding the brackets together. Also the inlet/y-pipe can be adjusted by loosening the muffler inlet clamps.

4. With the inlet springs installed, position the **Muffler Assembly** appropriately and fully tighten all fasteners.

Note:

The mufflers come with a quiet insert pre-installed to limit sound levels to 96dB at half-throttle. If increased flow is desired, use the **Ring Inserts** as follows:

- 1) remove the four (4) screws securing the outlet tips to the mufflers
- 2) remove the spark arrestor and quiet insert
- 3) replace the quiet insert with the supplied **Ring Insert** and replace the spark arrestor
- 4) reinstall the outlet tips

It is recommended that the muffler screws be retightened after the first ride and checked periodically thereafter, tightening if necessary.

Congratulations! You are ready to begin experiencing the improved performance and driving excitement of your MBRP Powersports SXS Exhaust upgrade. We know you will enjoy your purchase.



Figure 1



Figure 2



Figure 3



Figure 4

Spark Arrestor Maintenance

In order to maintain optimal performance, the spark arrestor screen should be cleaned after every 30-35 hours of use.

Clean-out Instructions:

Make sure the vehicle is cool before completing the clean-out procedure.

1. Using a 4mm hex key, remove the 4 screws securing the outlet cap or tip. **(Figure 1)**
2. Remove the outlet cap to expose the spark arrestor screen insert. **(Figure 2)**
3. Remove the screen insert. **(Figure 3)**
4. Using a wire brush, thoroughly brush the screen to remove residue. **(Figure 4)**
5. Replace the screen and cap.
6. Tighten the screws to 60 in-lbs (6.8 Nm).