

MBRP

AT-9214PT

MUFFLER ASSEMBLY, 5"

2015-2016 CAN-AM OUTLANDER L / L MAX 450/500 EFI

2017 CAN-AM OUTLANDER MAX 450/570

2018-2019 CAN-AM OUTLANDER / OUTLANDER MAX 450/570 EFI, T3, EXCL. PRO

2020-2021 CAN-AM OUTLANDER / OUTLANDER MAX 450/570 EFI ALL MODELS(DPS, 6X6, PRO)

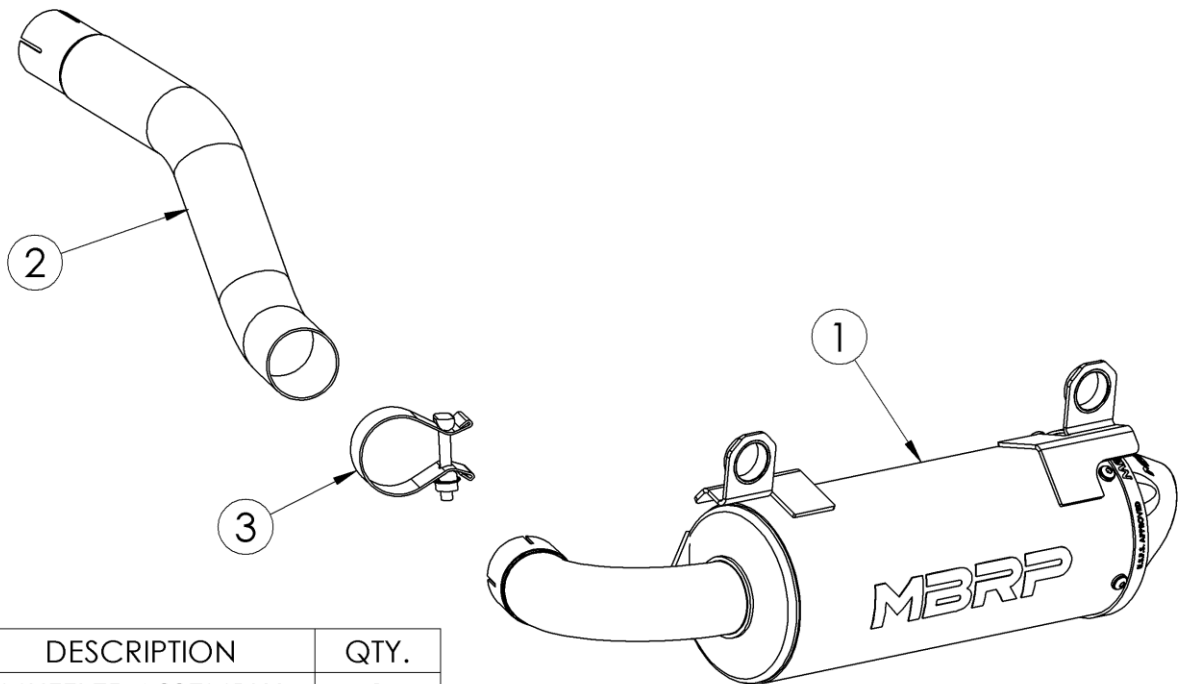

ITEM NO.	DESCRIPTION	QTY.
1	MUFFLER ASSEMBLY	1
2	INLET PIPE	1
3	2" CLAMP	1

PLEASE READ BEFORE STARTING INSTALLATION

While MBRP Ltd. has made every effort to ensure that all components of this system are of superior quality and properly packaged, it is the installer's responsibility to ensure the following before removal of the factory exhaust:

- that ALL components shown above are present.
- that ALL mating components fit together.
- that there are no damaged components.
- that the system you have purchased is appropriate for your vehicle year, model and configuration.
- that the system will not interfere with any modifications previously installed or planned.
- that you have read and understand these instructions.

If you have any questions or are uncertain about any aspect of the installation of this system to your vehicle please contact your dealer before commencing installation.

MBRP

Removal of Stock Exhaust:

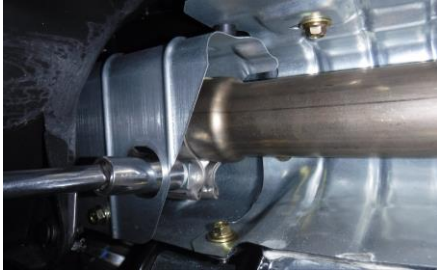

Figure 1

1. Loosen the clamp at the front pipe of the stock muffler. **Refer to Figure 1.**
2. Loosen and remove the hardware securing the muffler mounts to the rear frame. Support the muffler once the bolts are removed and take care not to lose the aluminum spacers from the rubber mounts. Keep the hardware (nuts, bolts, and washers) as it will be reused.
3. Work the stock muffler straight back to free it from the front pipe and remove it.

Installation of MBRP Exhaust:



Figure 2

1. Place the stock clamp onto the **Inlet Pipe**, then slide the **Inlet Pipe** onto the stock exhaust pipe. Leave the clamp loose to allow the pipe to be rotated into position as required. Slide the **2" Clamp** over the other end of the pipe.
2. Remove the two rubber mounting isolators and inner aluminum spacers from the stock muffler and insert them into the mounts of the new **Muffler Assembly**. **Refer to Figure 2.**
3. Put the **Muffler Assembly** into position by placing the muffler inlet onto the **Inlet Pipe**, and loosely replacing the hardware (bolts, washers, and nuts) through the aluminum spacers and into the mounting holes on the vehicle frame. **Refer to Figure 3.**
4. Ensure that the **Muffler Assembly** is properly aligned, then fully tighten the mounting hardware to the frame, followed by the **2" Clamp** on the muffler inlet and then the stock clamp at the front of the **Inlet Pipe**. **Refer to Figure 4.**



Figure 3

It is recommended that the muffler end cap screws be retightened after the first ride and checked periodically thereafter, tightening if necessary.



Figure 4

In order to maintain optimal performance, the spark arrestor screen should be cleaned after every 30-35 hours of use. The spark arrestor can be accessed by removing the four (4) screws and outlet tip. Retighten the screws to 60in-lbs (6.8Nm) when reassembling. **Refer to Figure 5.**

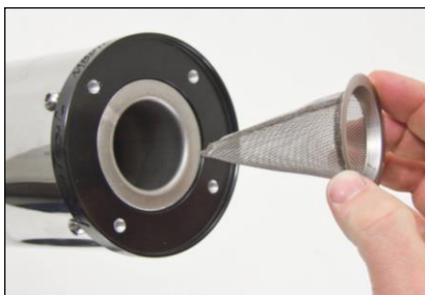

Figure 5



Congratulations! You are ready to begin experiencing the improved performance and driving excitement of your MBRP Ltd. Exhaust upgrade. We know you will enjoy your purchase.