



ATV/UTV RECOVERY WINCHES

INSTALLATION AND OPERATION MANUAL

Read manual carefully and understand all warnings and instructions before use.

Model RP25

2,500 lbs. Capacity

*Cable winch shown.

Also available with Dyneema® rope.



Model RP35

3,500 lbs. Capacity

*Cable winch shown.

Also available with Dyneema® rope.



Model RP50

5,000 lbs. Capacity

*Cable winch shown.

Also available with Dyneema® rope.



ISO/TS16949:2009

ZL 2008 3 0166399.6

Due to continuing improvement, the actual product may differ slightly from item described herein.

QUADBOSS WINCH MODEL RP25

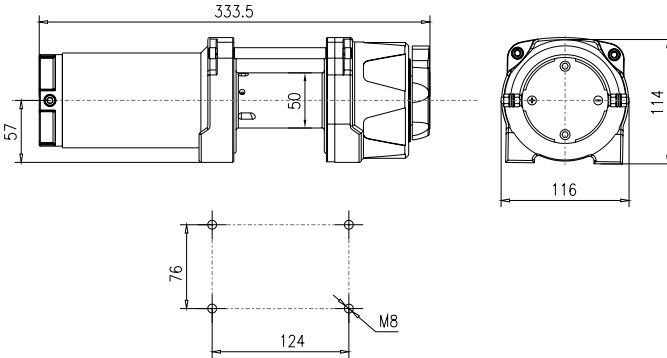

Features:

- 2-stage planetary gear system for fast line speed
- Automatic load-holding brake
- Free spooling
- Power-in and power-out
- 3Hp (2.25Kw) heavy-duty electric permanent magnetic motor
- Low electric current
- Protected against dust and water-resistant (rated IP67)

Specifications:

Rated line pull (Single line)	2,500 lbs./1,135kgs
Gear reduction ratio	241:1
Motor (permanent)	3Hp (2.25Kw), 12-Volt DC
Drum	Diameter 2" x Length 3.15"
Cable (min. break force 4,200 lbs.)	3/16" 39'
Dyneema® rope option	3/16" x 50
Overall dimension	13.1" x 4.6" x 4.5"
Net weight	15 lbs./6.8kg
Mounting bolt pattern	3" x 4.88"

Performance of 1st layer

Line Pull		Line Speed		Motor Current
Lbs	Kgs	Fpm	Mpm	Amp
0	0	19.7	6.0	31
1000	454	18.4	5.6	105
2000	907	14.8	4.5	145
2500	1135	13.5	4.1	195

Line Pull & Cable Capacity by Layer

Cable Layer	Rated Line Pull		Cable Capacity		Dyneema® rope Capacity	
	Lbs	Kgs	Feet	Meters	Feet	Meters
1	2500	1135	9.2	2.8	9.2	2.8
2	2130	967	20.3	6.2	20.3	6.2
3	1855	842	33.1	10.1	33.1	10.1
4	1643	746	39.4	12.0	47.6	14.5
5	1475	669	—	—	50.0	15.2

QUADBOSS WINCH MODEL RP35

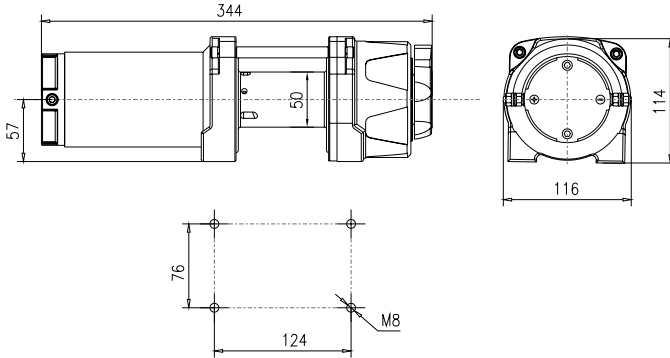

Features:

- 2-stage planetary gear system for fast line speed
- Automatic load-holding brake
- Free spooling
- Power-in and power-out
- 3.5Hp (2.6Kw) heavy-duty electric permanent magnetic motor
- Low electric current
- Protected against dust and water-resistant (rated IP67)

Specifications:

Rated line pull (single line)	3,500 lbs./1,589kgs
Gear reduction ratio	241:1
Motor (permanent)	3.5Hp (2.6Kw), 12-Volt DC
Drum	Diameter 2" x Length 3.15"
Cable (min. break force 5,600 lbs.)	
Dyneema® rope option	7/32" x 39'
Overall dimension	13.5" x 4.5" x 4.3"
Net weight	18 lbs./8.16kg
Mounting bolt pattern	1.89" x 3"

Performance of 1st layer

Line Pull		Line Speed		Motor Current
Lbs	Kgs	Fpm	Mpm	Amp
0	0	18.4	5.6	30
1000	454	15.0	4.6	86
2000	907	13.1	4.0	136
3500	1589	9.8	3.0	230

Line Pull and Cable Capacity by Layer

Cable Layer	Rated Line Pull		Cable Capacity		Dyneema® rope Capacity	
	Lbs	Kgs	Feet	Meters	Feet	Meters
1	3500	1589	8.2	2.5	9.2	2.8
2	2900	1317	18.0	5.5	20.3	6.2
3	2500	1135	29.2	8.9	33.1	10.1
4	2200	1000	42.0	12.8	47.6	14.5
5	1900	863	45	13.7	50.0	15.2

QUADBOSS WINCH MODEL RP50

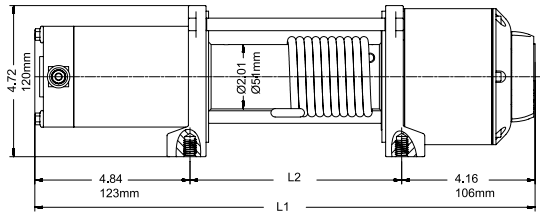

Features:

- 2-stage planetary gear system for fast line speed
- Automatic load-holding brake
- Free spooling
- Power-in and power-out
- 3Hp (2.25Kw) heavy-duty electric permanent magnetic motor
- Low electric current
- Protected against dust and water-resistant (rated IP67)

Specifications:

Rated line pull (Single line)	5,000 lbs./2,267kgs
Gear reduction ratio	165:1
Motor (permanent)	3.8Hp (2.8Kw), 12-Volt DC
Drum	Diameter 2.01" x Length 5.4"
Cable (min. break force 4,200 lbs.)	1/4" x 50'
Dyneema® rope option	1/4" x 50'
Overall dimension	15.62" x 4.61" x 4.72"
Net weight	23 lbs./10.43kg
Mounting bolt pattern	3" x 6.61"

Performance of 1st layer

Line Pull		Line Speed		Motor Current
Lbs	Kgs	Fpm	Mpm	Amp
0	0	20.7	6.3	34
2000	908	15.1	4.6	135
3000	1360	11.5	4.0	155
4000	1810	10.5	3.2	190
5000	2270	9.2	2.8	230

Line Pull & Cable Capacity by Layer

Cable Layer	Rated Line Pull		Cable Capacity		Dyneema® rope Capacity	
	Lbs	Kgs	Feet	Meters	Feet	Meters
1	5000	2270	-	-	-	-
2	4080	1852	-	-	-	-
3	3446	1565	-	-	-	-
4	2983	1354	-	-	-	-
5	2629	1194	-	-	-	-

INSTALLATION INSTRUCTIONS

Included with your winch:

- Winch 2,500/3,500 lbs.
- 250-Amp contactor
- .25" Hook w/ pull strap
- Roller hawse for cable winch or aluminum fairlead for Dyneema rope
- Handlebar rocker switch w/ handlebar mount
- Hand held rocker remote control
- Red positive battery cable 92" length
- Black ground battery cable 92" length
- Red positive winch cable 36" length w/ blue color ends
- Black ground winch cable 36" length w/ yellow color ends
- 4-pin harness
- M10 - 1.50 X 25mm (2 pc.)
- M10 - 1.50 Flange nut (2 pc.)
- M8 - 1.25 X 20mm (4 pc.)
- M8 split lock washer (4 pc.)
- M8 x 16mm od flat washer (4 pc.)
- M6 - 12mm od flat washer (4 pc.)
- M6 - 1.0 Flange nut (4 pc.)
- M6 - 1.0 X 50mm Phillips head screws (4 pc.)
- Rubber winch terminal boot cover (2 pc.) 1 red and 1 black

Tools Required:

- #1 Phillips Head Screw Driver
- #3 Phillips Head Screw Driver
- 4mm Allen Key
- 8mm Socket
- 15mm Wrench
- 15mm Socket
- 10mm Socket
- 13mm Socket
- Wire Strippers
- Quick Splice Connector(s)

BEFORE WINCH INSTALLATION:

- Disconnect the vehicle's negative (-) battery cable first and then the positive (+) cable from the battery
- Install the winch mount (sold separately) that is specified for your ATV/UTV. Sequence may vary per application

MOUNTING THE WINCH

- Place the QuadBoss Winch in the winch mount and secure using the M8 split lock washers and M8 bolts
- Next place the roller fairlead/hawse fairlead in front of the winch mount, pulling the rope through the opening
- Remove the cotter pin and clevis pin from the .25" hook to attach to the cable/rope
- Reinstall the clevis pin and cotter pin to secure the hook to the cable/rope

MOUNTING THE CONTACTOR

- When mounting the winch contactor, it is recommended to mount in a suitable, clean and dry location (verify that you have sufficient clearance)
- If drilling is required for mounting holes, making sure electrical wires and/or components will not be damaged when drilling
- Use the supplied hardware, (M6 Phillip head screws, washers and corresponding nuts) to properly mount the contactor to your ATV/UTV

WIRING THE CONTACTOR

Note: Ground cable should NOT be connected to battery terminal until installation is complete!

- Using the 92" positive (RED) cable, connect one end to the RED terminal on the contactor
- Connect the other end of the RED cable to the positive terminal of the battery
- Using the 92" negative (BLACK) cable, connect one end to the BLACK terminal on the contactor. Leave the other end of cable disconnected until installation is complete (connecting the ground cable to the battery should be the last step in the installation)
- Using the 36" Positive (RED) cable with blue heat shrink, connect one end to the BLUE terminal on the contactor
- Using the red terminal boot protector, slide it over the opposite end of the cable and then to the positive terminal on the winch
- Using the 36" Negative (BLACK) cable with the yellow heat shrink, connecting one end to the contactor that has been colored YELLOW
- Using the black terminal boot protector, slide it over the opposite end of the cable and then connect cable to the negative terminal on winch

Note: Depending on location of the contactor, you may need to use the shorter black/red cables in place of the longer red/black cables. In this case, the wiring configuration of the color coded terminals will change.



CONTACTOR



4-PIN HARNESS



4-PIN TO CONTACTOR



HANDLEBAR AND WIRELESS REMOTE



WIRELESS REMOTE



HANDLEBAR AND HAND REMOTE



HANDLEBAR ONLY

INSTALLATION INSTRUCTIONS CONTINUED

MOUNTING THE HANDLEBAR SWITCH

- The handlebar switch is usually mounted on the left side of the handlebar, but can be mounted on either side
 - TIP:** A piece of electrical tape wrapped around the handlebar where the switch will be mounted can help prevent rotation of the mount on the handlebar.
- Once the switch is mounted, route the wires to the location of the contactor (check for handlebar range of motion when routing wires)
- The brown and blue wires from the switch should then be connected directly to the brown and blue leads on the contactor
- The red wire will need to be connected to a keyed power source (a test light may be needed to locate a suitable source of power)
- The red wire should only have power when the key is in the "ON" position
- Verify that you have full range of motion of the handlebars with no binding issues
- Secure all wiring to prevent from coming loose in the future

MOUNTING THE 4-PIN HARNESS (OPTIONAL)

- The 4-pin harness is required when connecting the handheld controller and/or wireless controller (sold separately); it is also required when using two controllers at the same time; it is recommended to find a location near the contactor to drill a 22mm hole to securely mount the 4-pin harness into your body work
- Insert the harness into the drilled hole to connect to the brown and blue leads coming out of the contactor
- The brown and blue wires have a splitter on each end that can be connected to the handlebar switch for the using two controllers simultaneously
- Using the base of the 4-pin harness connector as a template, drill two 5mm holes on either side of your 22mm hole and secure using the fasteners supplied with the harness; the black wire with the ring connector needs to be connected to a ground; the red wire would need to be connected to a keyed power source (a test light may be needed to locate a suitable source of power)
- The red wire should only have power when the key is in the "ON" position
- Connect the remaining 92" negative (BLACK) cable end to your battery ground

WINCH OPERATION

Clutch Operation:

The clutch is operated by turning the Clutch Knob clockwise about 45-90° to the "DISENGAGE" position.

This will allow you to free spool the winch.

Turn the Clutch Knob counter-clockwise to "ENGAGE" position until it pops back into place, allowing it to go into gear.

CAUTION: Never release the wire rope while under tension. Doing this can badly damage the winch, cause property damage and/or serious injury.

Wire Rope Handling:

Grab the hook using the Hand Saver Strap and pull the wire rope to the desired length. Then attach the hook to item being pulled. Make sure the hook spring-loaded latch is set.

CAUTION: Always leave at least five turns of wire rope on the drum. Review Winch Safety Warnings and Precautions before continuing.

Winching loads:

While standing aside of the tow path, press and hold the push button on the remote control to pull the load. If the load will not move, release pull switch and check for obstacles blocking the load or check to see if load is too heavy for winch capacity.

CAUTION: This winch is designed for intermittent use only, and should not be used in a constant duty application. The duration of the pulling job should be kept as short as possible. If the winch motor becomes very hot to touch, stop the winch and let it cool down for several minutes. Never pull for more than one minute at or near the rated load. Do not maintain power to the winch if the motor stalls as it can damage the motor or gear.

Note: A fully charged battery will give best service. The engine should be kept running during operation.

INSTALLATION PRECAUTIONS

- If you choose not to use an ATV mounting kit, you may be required to drill holes into a structural support
- Be sure the location will be strong enough to support the rated pulling force of the winch
- Do not drill into wiring or fuel tank
- If mounting requires bolts different than the length supplied, use a bolt of equal or better quality
- Torque the kits 5/16" Grade 8 mounting bolts to 12 lbs.-ft.(1.7kg-m)
- Make sure the winch mounting bolts and winch hardware has been checked for proper torque
- When attaching wires to the motor terminals, hold the inner nut with a second wrench to keep the terminal from rotating in the housing; this will help avoid internal wire breakage (image A)
- Always use the Hand Saver strap when the hook is near the fairlead or winch drum
- Before testing the winch, set the clutch to free spool position by turning the Clutch Knob clockwise (image B); pull about 2 feet of wire rope off the winch and set the Clutch Knob to engaged position by turning it counter-clockwise (Image C)
- Always wear heavy gloves when handling heavy wire rope

SAFETY WARNINGS AND PRECAUTIONS

- Do not operate winch under influence of drugs or alcohol
- Read manual before using this winch
- Always use heavy gloves when handling wire rope
- Never hook the cable back upon itself
- The cable can break under tension and cause injury and damage
- Stay clear of wire rope and keep others away when in operation or with load on wire
- Inspect winch and wire rope before each use
- Do not use winch if wire rope or winch shows wear or damage
- Replace any parts as needed before using the winch
- Do not exceed the winch capacity
- Do not place hands near the fairlead when winch is in operation
- Always use the protective hand-saving belt when spooling
- Do not use the winch as a hoist or to move people
- Do not use winch to secure a load or tow vehicles

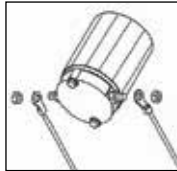

Image A



Image B



Image C

PROPER WINCHING TECHNIQUE

BE SAFE

Take all precautions and use common sense to avoid injury and property damage before operating winch. Electric winch is for intermittent use only. Place a towel or winch accessory bag over wire cable while winch is in use. In case of a breakage, this will help disperse the kinetic energy of the cable, keeping it closer to the ground to avoid injury.

WINCHING USING A TREE AS AN ANCHOR POINT

Use QuadBoss Winch Accessory Kit (P/N 608994 sold separately) when using a tree as an anchor point for winching. Wrap the 1"x 8" Tree Trunk Protector strap around the tree to protect it from damage when winching.

WINCHING USING A SNATCH/PULLEY BLOCK

To double the pulling power of your winch, use the snatch/pulley block included in the QuadBoss Winch Accessory Kit (P/N 608994 sold separately). Pull the winch cable through the snatch block around the pulley.

Unscrew the pin on .25" D-Shackle. Slide both looped ends of the Tree Trunk Protector strap and the open ends of the snatch block around the .25" D-Shackle. Reinsert pin into the .25" D-Shackle to secure Tree Trunk Protector strap to the snatch/pulley block. Use the Hand Saver strap to carefully pull the winch rope/cable back to your ATV/UTV.

With the open end of the hook facing upward, connect the hook to the frame or tow hook at a downward angle.

Caution: Keep hands clear of wire rope, hook and roller fairlead opening during winch operation.

Always use Hand Saver strap to hold the hook when spooling winch.

WINCHING USING A SNATCH/PULLEY BLOCK

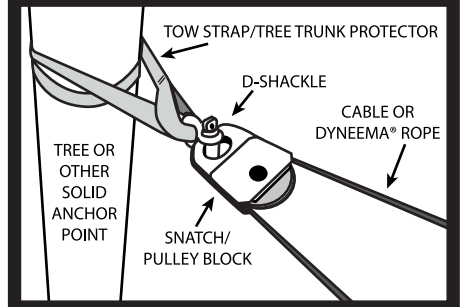

MAINTENANCE

LUBRICATION:

1. All moving parts within the winch have been lubricated using high-temp lithium grease at the factory; no internal lubrication is required.
2. Lubricate wire rope periodically using a light penetrating oil.

CABLE ASSEMBLY REPLACEMENT (to be performed only by a qualified service tech.)

1. Move clutch knob to the OUT position.
2. Extend cable assembly to its full length;
note how the existing wire rope is connected to the inside of the drum.
3. Remove old cable assembly and attach new one.
4. Retract cable onto drum being careful not to allow kinking.

GENERAL

1. Keep vehicle battery in good condition.
2. Be sure that the winch battery cables are not drawn tight against any surfaces, which could possibly damage them.
3. Periodically remove and clean cable connections to the battery fuse box and chassis ground;
corrosion will reduce performance or may cause a short.
4. Cover the cables and winch when not in use.

TROUBLE SHOOTING

SYMPTOM	POSSIBLE CAUSE	SUGGESTED REMEDY
Motor does not turn on	Switch assy. not connected properly	Insert switch assy. firmly to the connector
	Loose battery cable connection	Tighten nuts on cable connectors
	Contacter malfunctioning	Tap contactor to free contact, apply 12 volts to coil terminal directly
	Defective motor	Check for voltage at armature port with switch pressed. If voltage is present, replace motor
	Water has entered motor	Drain and dry; run in short bursts without load until completely dry
Motor runs too hot	Long period of operation	Let winch cool down periodically
Motor runs slowly or without normal power	Battery run down	Recharge battery by running vehicle engine
	Insufficient current or voltage	Clean, tighten or replace the connector
Motor runs but cable drum does not turn	Clutch not engaged	Push Clutch Knob into IN position; if that does not work, ask a qualified technician to check and repair
Motor runs in one direction only	Defective or stuck solenoid	Tap solenoid to free contacts Repair or replace solenoid
	Defective switch assy.	Replace switch assy.
Makes audible clicking when activating	Defective switch assy.	Replace switch assy.