



SEDONA[®]

T I R E A N D W H E E L





TABLE OF CONTENTS

<i>TIRES</i>	2
• <i>ATV/UTV Tires</i>	4
• <i>Motorcycle Tires</i>	24
<i>WHEELS</i>	32
• <i>Beadlock Wheels</i>	34
• <i>Non-Beadlock Wheels</i>	38
• <i>Wheel Sizing Charts</i>	47
<i>TUBES & ACCESSORIES</i>	52

TIRES





ATV/UTV TIRES



ROCK-A-BILLY



Designed specifically for today's performance UTV's and ATV's. The Sedona Rock-A-Billy radial tire has been proven as a true performance race tire at several championship series. It is also a top pick for upgrading from your stock UTV/ATV tires.

- 8 ply rated puncture resistant RADIAL construction
- Aggressive tread design with integrated side lugs to grip in extreme riding conditions
- All new tread compound designed to outlast, out-grip and out-perform the competition
- Integrated rock ejectors in tread design
- Built in rim guard for added protection
- Designed to match the high-horsepower, high-speed requirements of today's side-by-sides
- Bead-to-bead layer of puncture resistant material
- NOTE: Yellow balance dot needs to be positioned opposite the valve stem

Size	Ply Rating	WPS#
26x9R-12	8 PR	570-5200
26x11R-12	8 PR	570-5202
28x10R-14	8 PR	570-5205
30x10R-14	8 PR	570-5206
32x10R-14	8 PR	570-5207
32x10R-15	8 PR	570-5208

RIP-SAW R/T



The Rip-Saw RT is an extreme terrain aggressive radial. The deep tread pattern cleans out well in mud and offers great traction and long lasting wear in all types of extreme terrain.

- RADIAL construction
- Tread pattern wraps onto the sidewall to increase traction in deep-rutted and muddy conditions
- Deep aggressive tread pattern that cleans out well in mud and offers great traction in all types of extreme terrain
- 28" and 30" sizes are a 8 ply heavy duty carcass
- NOTE: Yellow balance dot needs to be mounted opposite the valve stem

Size	Ply Rating	WPS#
25x8R-12	6 PR	570-5100
25x10R-12	6 PR	570-5101
26x9R-12	6 PR	570-5102
26x10R-12	6 PR	570-5103
26x9R-14	6 PR	570-5105
26x11R-12	6 PR	570-5104
26x11R-14	6 PR	570-5106
27x9R-14	6 PR	570-5107
27x11R-14	6 PR	570-5108
28x10R-14	8 PR	570-5109
30x10R-14	8 PR	570-5110





MUD REBEL R/T



The Mud Rebel R/T takes it to the next level with 8 Ply, heavy-duty radial construction to offer stability and control. Its high grade rubber compound brings the ultimate in traction and excellent tread life wear.

- Deep aggressive tread pattern that works excellent on trail or in extreme conditions
- Computer designed "smooth ride" tread pattern offers a comfortable ride and excellent traction
- 8 Ply heavy duty RADIAL construction offers stability, control
- High grade rubber compound brings the ultimate in traction and excellent tread life wear

Size	Ply Rating	WPS#
25x8R-12	8 PR	570-4070
25x10R-12	8 PR	570-4071
26x9R-12	8 PR	570-4072
26x10R-12	8 PR	570-4073
26x11R-12	8 PR	570-4074
26x9R-14	8 PR	570-4075
26x11R-14	8 PR	570-4076
28x10R-14	8 PR	570-4078
30x10R-15	8 PR	570-4081

BUZZ SAW R/T



The high quality rubber compound that used in the Buzz Saw R/T is similar to the rubber compound used in high-speed radial truck tires. The result: a tire that lasts, rides smooth and quiet, and offers great traction.

- Lightweight ultra smooth riding RADIAL construction, designed for today's larger ATV/UTV needs
- 7/8" deep tread design offers excellent traction, while providing a smooth ride
- The heavy duty, radial carcass construction is lightweight and is designed for added stability and an ultra smooth ride
- High-grade rubber compound offers long tread life

Size	Ply Rating	WPS#
23x11R-10	6 PR	570-5009
24x11R-10	6 PR	570-5010
25x8R-12	6 PR	570-5000
25x10R-12	6 PR	570-5001
26x9R-12	6 PR	570-5004
26x10R-12	6 PR	570-5005
26x11R-12	6 PR	570-5006
26x9R-14	6 PR	570-5002
26x11R-14	6 PR	570-5003
27x9R-14	6 PR	570-5007
27x11R-14	6 PR	570-5008





MUDDA INLAW



Do you like MUD?! The Mudda Inlaw offers a deep aggressive lug with 8 Ply puncture resistant RADIAL construction. This tire offers an exceptionally smooth ride and long wear for such an aggressive tire. Mount up the most aggressive mud tire in the Sedona tire lineup and get out there and get dirty with the Mudda InLaw!

- 2" deep center lug increases to 2-1/4" at the outside edge to paddle you through mud pits quickly
- Ultra strong 8 Ply, puncture resistant RADIAL construction
- Superior handling, ride quality, tread life, and grip
- Tread design wraps down sidewall deep paddling traction
- Aggressive mud tread pattern offers exceptional deep mud traction, self cleaning, and is relatively smooth running on transfer sections

Size	Ply Rating	WPS #
28x10R-14	8 PR	570-4102
30x10R-14	8 PR	570-4100
32x10R-14	8 PR	570-4101

COYOTE



One of the newest tires to hit the Sedona tire line up! The Sedona Coyote tire offers incredible traction and performance at a very affordable price! Utilizing today's high-tech manufacturing process the Sedona Coyote delivers a smooth ride, predictable handling and excellent tread life.

- Ultra-durable, puncture-resistant 6 Ply Rated "New-Tech" carcass
- 28x10R14 upgraded to an 8 Ply heavy duty RADIAL carcass
- "Smooth-Ride" Technology and aggressive tread design for excellent traction and a smooth ride in all terrain
- Integrated side lugs for added traction in deep ruts or crawling through the rocks
- Tread lugs are siped for added traction and durability
- Built-in "Rim Guard" for added wheel protection
- Unmatched ride quality and performance in the category

Bias	Size	Ply Rating	WPS#
	25x8-12	6 PR	570-4200
	25x10-12	6 PR	570-4201
	27x9-12	6 PR	570-4204
	27x11-12	6 PR	570-4205

Radial	Size	Ply Rating	WPS#
	28x10R14	8 PR	570-4206





BUCK SNORT



At Sedona Tire & Wheel we believe in producing the highest quality tires while maintaining the reason we all got into powersports...FUN! We bring you the Buck Snort tire. Using the proven "New Tech" carcass as our Coyote Tire, functional deer hooves designed into the tread and raised antlers on the side wall for added protection. Its time to really leave "tracks" on the trail!

- Ultra-durable, puncture-resistant 6 Ply Rated New-Tech carcass
- Functional Deer Hoof center tread design leaves tracks down the trail
- Aggressive tread with integrated side lugs grip in extreme conditions
- Tread lugs are siped for added traction and durability
- Built-in rim guard for added wheel protection
- Ultimate ride quality and performance in the category



Size	Ply Rating	WPS#
25x8-12	6 PR	570-4350
25x10-12	6 PR	570-4351
27x9-14	6 PR	570-4352
27x11-14	6 PR	570-4353

MUD REBEL



Designed for the aggressive mud and utility ATV rider or UTV driver, the Sedona Mud Rebel tire performs incredible in mud and also handles dry trails and rocks with ease. High-quality carcass materials allow for controlled inflated sizes that allow your vehicle to perform at its highest level of performance. The Mud Rebel also offers increased sidewall strength for puncture resistance and impact absorption while carrying heavy loads.

- Aggressive tread design features angled lugs to achieve an exceptional level of traction
- Sidewall lugs are designed to offer added traction in deep ruts
- Great steering response and puncture resistance
- 6 ply rated construction

	Size	Ply Rating	WPS#
FRONT	22x8-10	6 PR	570-4012
	22x11-9	6 PR	570-4010
	23x8-10	6 PR	570-4014
	23x9-11	6 PR	570-4017
	24x8-12	6 PR	570-4001
	25x8-12	6 PR	570-4000
	26x9-12	6 PR	570-4002
	27x10-14	6 PR	570-4003

	Size	Ply Rating	WPS#
REAR	22x11-10	6 PR	570-4013
	23x10-10	6 PR	570-4015
	24x11-10	6 PR	570-4016
	24x10-11	6 PR	570-4018
	25x11-10	6 PR	570-4005
	24x9-11	6 PR	570-4009
	25x10-12	6 PR	570-4004
	26x10-12	6 PR	570-4006
	26x12-12	6 PR	570-4007
	27x12-14	6 PR	570-4008

CYCLONE



The ultra lightweight Cyclone sand tires bring traction, flotation, predictable turning and sidehilling to a new level. The ultra lightweight rib front completes the Cyclone sand setup. The Cyclone is a proven sand dune tire with experience at major sand parks in the USA. The premium rubber compound used in the Cyclone sand tire is part of the magic with this tire. The rubber is strong, yet flexible and lightweight, to bring a new level of traction while lasting a long time. The Cyclone sanddune tire works well in dry light sand, wet heavy sand, and even in volcanic sand.

- Lightweight design
- Alternating centered dual ribs
- 8 large paddle design
- Back support ridges for controlled slides on ridge-back dunes

FRONT	Size	WPS#	
	19x6-10	570-2000	
	21x7-10	570-2001	
REAR	Size		WPS#
	20x11-8	Left	570-2002L
		Right	570-2002R
	20x11-9	Left	570-2003L
		Right	570-2003R
	20x11-10	Left	570-2004L
		Right	570-2004R

BAZOOKA



The Bazooka MX/X-Country features 4 ply construction and a race-grade high-silica rubber compound that offers incredible traction and ultra long tread wear. Only the best quality materials are used in the carcass design and large sidewall lugs increase cornering traction and stability. The result is the perfect MX track or cross-country trail riding tire without the high price typically associated with performance tires.

- Performance rubber compound for lasting durability
- Large sidewall lugs for great cornering
- Perfect compound for trail or track riding

FRONT	Size	Ply Rating	WPS#
	19x6-10	4 PR	570-3100
21x7-10	4 PR	570-3104	
REAR	Size	Ply Rating	WPS#
	18x10-8	4 PR	570-3103
	18x10-9	4 PR	570-3101
	18x10-10	4 PR	570-3102
	20x11-8	4 PR	570-3105
	20x11-9	4 PR	570-3106
20x11-10	4 PR	570-3107	
21x11-9	4 PR	570-3108	







POLARIS

SEDONA
TIRE AND WHEEL

MOTORCYCLE TIRES



MX907HP (HARD-PACK TERRAIN)



The MX907HP features a compound designed for blue-groove hard-pack terrain traction. A cross-patch tread design provides a larger contact patch that maximizes both in-line and cornering traction.

- Multi-knob tread pattern technology assures a large footprint
- Siped and dimpled knobs add more bite-edges for the ultimate in traction
- Rigid 4 ply carcass enhances stability and absorbs impacts

	Description	WPS#
FRONT	80/100-21	870-1065
REAR	110/100-18	870-1060
	120/90-18	870-1061
	100/90-19	870-1062
	110/90-19	870-1063
	120/80-19	870-1064

MX887IT (INTERMEDIATE TERRAIN)



The MX887IT is an ideal intermediate to hard terrain tire with its rigid 4-ply carcass design that helps reduce sidewall flex for a more planted feel.

- Works in intermediate to hard terrain
- Side knobs offers superior grip at extreme angles
- Reversible tread pattern and symmetrical knob design allows for equal traction in both directions

	Description	WPS#
FRONT	2.50-10	870-1011
	60/100-14	870-1013
	70/100-17	870-1000
	70/100-19	870-1001
	80/100-21	870-1002
REAR	2.75-10	870-1012
	80/100-12	870-1014
	90/100-14	870-1004
	90/100-16	870-1005
	110/100-18	870-1006
	120/90-18	870-1007
	100/90-19	870-1008
	110/90-19	870-1009
120/80-19	870-1010	



MX880ST (SOFT TERRAIN)



The MX880ST features an intermediate/soft terrain compound ideal for sand and mud. The MX880ST offers performance without a high price so you can spend more time at the track or on the trail.

- Open Cross Block supported tread pattern
- Side knobs with 8 biting edges offer excellent cornering performance
- Rigid 4 ply rated carcass design
- Open tread pattern cleans out quickly in sand and mud

FRONT	Description	WPS#
	70/100-17	870-1050
80/100-21	870-1051	

REAR	Description	WPS#
	90/100-14	870-1052
110/100-18	870-1053	
120/90-18	870-1054	
100/90-19	870-1055	
110/90-19	870-1056	
120/80-19	870-1057	

DUNATIK MX



The Dunatik gives you serious sand performance with its ultra-light carcass and paddle design. It gives serious dune performance at a seriously good price. It also brings traction and flotation to a new level.

- Ultra-light 2-ply nylon carcass design

Description	WPS#
110/100-18 8 paddle	870-2002
110/90-19 8 paddle	870-2000
110/90-19 10 paddle	870-2001





SEDONA
THE BEYOND WHEEL

WHEELS





**BEADLOCK
WHEELS**



SPLIT SIX BRONZE BEADLOCK



The Split Six is our newest true beadlock wheel to hit the Sedona product line. From racing to recreation this wheel is built with performance and value in mind. Keep your tires Locked-N-Loaded with the Sedona Split Six Beadlock.

- Constructed of Hi-Grade aluminum
- Ultra strong and lightweight
- Dual drilled beadlock ring
- Inset valve stem location
- Caps included

[Sizing chart on page 48](#)

SPLIT SIX BEADLOCK



The Split Six is our newest true beadlock wheel to hit the Sedona product line. From racing to recreation this wheel is built with performance and value in mind. Keep your tires Locked-N-Loaded with the Sedona Split Six Beadlock.

- Constructed of Hi-Grade aluminum
- Ultra strong and lightweight
- Dual drilled beadlock ring
- Inset valve stem location
- Caps included

[Sizing chart on page 48](#)

STORM BEADLOCK



Need a true race-inspired beadlock wheel that will stand up to the punishment of the Mint 400? Our dual-drilled beadlock design is ideal for track side maintenance.

- Constructed of high-grade aluminum
- Strong and lightweight
- Dual drilled beadlock technology
- Inset valve stem location
- Caps included

[Sizing chart on page 49](#)

NON-BEADLOCK WHEELS



SPARX



The ALL-NEW Sedona SPARX wheel is an 8-Spoke design featuring an automotive quality Satin-Black painted finish and a machined "rivet" look. Available in the common 14x7 sizes as well as a larger 15x7. Mount a set of our 30x10R-15 8-Ply Rated Sedona Mud Rebel RT tires on the 15x7 Sedona Sparx wheel for an aggressive look that will outperform the competition.

- Constructed of high-grade aluminum
- Strong and lightweight
- Dual drilled beadlock ring
- Inset valve stem location
- Caps included

[Sizing chart on page 48](#)

CHOPPER



Looking for a super clean high-gloss wheel? The NEW Sedona Chopper wheel is available in all black or with machined blades. Painted with high-quality automotive painting processes these wheels are designed to hold up and look good even in the toughest conditions.

- Constructed of high-grade aluminum
- Strong and lightweight
- Inset valve stem location
- Caps included
- Only available in 14x7

[Sizing chart on page 47](#)

CHOPPER MACHINED



Looking for a super clean high-gloss wheel? The NEW Sedona Chopper wheel is available in all black or with machined blades. Painted with high-quality automotive painting processes these wheels are designed to hold up and look good even in the toughest conditions.

- Constructed of high-grade aluminum
- Strong and lightweight
- Inset valve stem location
- Caps included
- Only available in 14x7

[Sizing chart on page 47](#)

RUKUS



Cause a RUKUS with Sedona's RUKUS wheels! Customize your Sedona Rukus wheels to match the color of your machine color with the optional Color inserts. Each wheel has four (4) interchangeable color injected plastic inserts that can be changed to your liking. Run it with the stock Gunmetal Grey inserts or chose from Red, Blue, Orange or Green!

- Constructed of Hi-Grade aluminum
- Ultra strong and lightweight
- Dual drilled beadlock ring
- Inset valve stem location
- Caps included

Sizing chart on page 47.
Color inserts on page 58.



HOLLOW POINT



Originally designed as the perfect non-beadlock wheel to go along with our Sedona Duntik UTV sand tires, the Sedona Hollow Point wheels are available in a 14x8 (front) and a 14x10 (rear). Or run the 14x8 Sedona Hollow Point wheel on all four corners of your UTV for a wider stance and increased stability. Mount a set of 30x10R-14 Sedona Rock-A-Billy tires on these wheels to add a truly custom look to your UTV.

- Constructed of high-grade aluminum
- Strong and lightweight
- Dual drilled beadlock ring
- Inset valve stem location
- Caps included

[Sizing chart on page 47](#)

RIOT



Disturb the norm with Sedona's Riot Wheel. Available in a wide range of sizes and offset this wheel is sure to cause a revolution!

- Constructed of Hi-Grade aluminum
- Ultra strong and lightweight
- Dual drilled beadlock ring
- Inset valve stem location
- Caps included

[Sizing chart on page 47](#)

STORM



High-strength aluminum with polished black accents, these Storm ATV/UTV wheels are sleek, lightweight and strong.

- Constructed of high-grade aluminum
- Strong and lightweight
- Dual drilled beadlock technology
- Inset valve stem location
- Caps included

Sizing chart on page 49

SPYDER



The Spyder wheel is manufactured from aluminum with a stealthy black finish. Rugged hardened construction to withstand anything a ATV or UTV can throw at them.

- Constructed of Hi-Grade aluminum
- Ultra strong and lightweight
- Dual drilled beadlock ring
- Inset valve stem location
- Caps included

[Sizing chart on page 48](#)

WHEEL SIZING CHARTS

CHOPPER

Size	Industry Offset	True Offset	Bolt Pattern	WPS#
14x7	5+2	+10mm	4/110 12mm Tapered	570-1290
14x7	5+2	+10mm	4/137 12mm Tapered	570-1291
14x7	4+3	+5mm	4/156 12mm Tapered	570-1292

CHOPPER MACHINED

Size	Industry Offset	True Offset	Bolt Pattern	WPS#
14x7	5+2	+10mm	4/110 12mm Tapered	570-1280
14x7	5+2	+10mm	4/137 12mm Tapered	570-1281
14x7	4+3	+5mm	4/156 12mm Tapered	570-1282

HOLLOW POINT

Size	Industry Offset	True Offset	Bolt Pattern	WPS#
14x8	4+4	0mm	4/110 12mm Tapered	570-1330
14x8	4+4	0mm	4/137 12mm Tapered	570-1331
14x8	4+4	0mm	4/156 12mm Tapered	570-1332
14x10	5+5	0mm	4/110 12mm Tapered	570-1333
14x10	5+5	0mm	4/137 12mm Tapered	570-1334
14x10	5+5	0mm	4/156 12mm Tapered	570-1335

RIOT

Size	Industry Offset	True Offset	Bolt Pattern	WPS#
12x7	5+2	-47mm	4/110 12mm Tapered	570-1250
12x7	2+5	+10mm	4/110 12mm Tapered	570-1251
12x7	5+2	-47mm	4/115 12mm Tapered	570-1252
12x7	5+2	+10mm	4/137 12mm Tapered	570-1255
12x7	4+3	+5mm	4/156 12mm Tapered	570-1256
14x7	6+1	+30mm	4/110 12mm Tapered	570-1257
14x7	5+2	+10mm	4/110 12mm Tapered	570-1258
14x7	2+5	-47mm	4/110 12mm Tapered	570-1259
14x7	5+2	+10mm	4/115 12mm Tapered	570-1260
14x7	5+2	+10mm	4/137 12mm Tapered	570-1261
14x7	6+1	+30mm	4/156 12mm Tapered	570-1263
14x7	4+3	+5mm	4/156 12mm Tapered	570-1264
15x7	5+2	+10mm	4/110 12mm Tapered	570-1265
15x7	5+2	+10mm	4/115 12mm Tapered	570-1266
15x7	5+2	+10mm	4/137 12mm Tapered	570-1267
15x7	4+3	+5mm	4/156 12mm Tapered	570-1269

RUKUS

Size	Industry Offset	True Offset	Bolt Pattern	WPS#
14x7	5+2	+10mm	4/110 12mm Tapered	570-1270
14x7	5+2	+10mm	4/115 12mm Tapered	570-1271
14x7	5+2	+10mm	4/137 12mm Tapered	570-1272
14x7	4+3	+5mm	4/156 12mm Tapered	570-1273
14x7	6+1	+30mm	4/110 12mm Tapered	570-1274
14x7	6+1	+30mm	4/156 12mm Tapered	570-1275

WHEEL SIZING CHARTS

SPARX

Size	Industry Offset	True Offset	Bolt Pattern	WPS#
14x7	5+2	+10mm	4/110 12mm Tapered	570-1300
14x7	2+5	-47mm	4/110 12mm Tapered	570-1301
14x7	5+2	+10mm	4/137 12mm Tapered	570-1302
14x7	4+3	+5mm	4/156 12mm Tapered	570-1303
14x7	6+1	+30mm	4/110 12mm Tapered	570-1304
14x7	6+1	+30mm	4/137 12mm Tapered	570-1305
14x7	6+1	+30mm	4/156 12mm Tapered	570-1306
15x7	5+2	+10mm	4/110 12mm Tapered	570-1307
15x7	5+2	+10mm	4/137 12mm Tapered	570-1308
15x7	4+3	+5mm	4/156 12mm Tapered	570-1309

SPLIT SIX BEADLOCK BRONZE

Size	Industry Offset	True Offset	Bolt Pattern	WPS#
14x7	5+2	+10mm	4/110 12mm Tapered	570-1340
14x7	5+2	+10mm	4/137 12mm Tapered	570-1342
14x7	4+3	+5mm	4/156 12mm Tapered	570-1343
14x7	6+1	+30mm	4/110 12mm Tapered	570-1344
14x7	6+1	+30mm	4/156 12mm Tapered	570-1345
14x10	5+5	0mm	4/110 12mm Tapered	570-1346
14x10	5+5	0mm	4/137 12mm Tapered	570-1348
14x10	5+5	0mm	4/156 12mm Tapered	570-1349
15x6	5+1	+38mm	4/137 12mm Tapered	570-1352
15x6	5+1	+38mm	4/156 12mm Tapered	570-1353

SPLIT SIX BEADLOCK

Size	Industry Offset	True Offset	Bolt Pattern	WPS#
14x7	5+2	+10mm	4/110 12mm Tapered	570-1240
14x7	5+2	+5mm	4/115 12mm Tapered	570-1241
14x7	5+2	+30mm	4/137 12mm Tapered	570-1242
14x7	4+3	+30mm	4/156 12mm Tapered	570-1243
14x7	6+1	0mm	4/110 12mm Tapered	570-1244
14x7	6+1	0mm	4/156 12mm Tapered	570-1245
14x10	5+5	0mm	4/110 12mm Tapered	570-1246
14x10	5+5	0mm	4/137 12mm Tapered	570-1248
14x10	5+5	+10mm	4/156 12mm Tapered	570-1249
15x6	5+1	+38mm	4/137 12mm Tapered	570-1350
15x6	5+1	+38mm	4/156 12mm Tapered	570-1351

SPYDER

Size	Industry Offset	True Offset	Bolt Pattern	WPS#
12x7	5+2	+10mm	4/110 12mm Tapered	570-1140
12x7	2+5	-47mm	4/110 12mm Tapered	570-1141
12x7	5+2	+10mm	4/115 12mm Tapered	570-1142
12x7	4+3	+5mm	4/156 12mm Tapered	570-1146
12x7	5+2	+10mm	4/137 12mm Tapered	570-1147
14x7	5+2	+10mm	4/110 12mm Tapered	570-1150
14x7	5+2	+10mm	4/115 12mm Tapered	570-1151
14x7	4+3	+5mm	4/156 12mm Tapered	570-1153
14x7	5+2	+10mm	4/137 12mm Tapered	570-1155

WHEEL SIZING CHARTS

STORM

Size	Industry Offset	True Offset	Bolt Pattern	WPS#
12x7	5+2	+10mm	4/137 12mm Tapered	570-1159
12x7	5+2	+10mm	4/110 12mm Tapered	570-1160
12x7	2+5	+10mm	4/110 12mm Tapered	570-1161
12x7	5+2	+10mm	4/115 12mm Tapered	570-1162
12x7	4+3	+10mm	4/156 12mm Tapered	570-1166
14x7	5+2	+5mm	4/110 12mm Tapered	570-1167
14x7	5+2	+10mm	4/115 12mm Tapered	570-1168
14x7	4+3	+10mm	4/156 12mm Tapered	570-1170
14x7	5+2	+10mm	4/137 12mm Tapered	570-1172

STORM BEADLOCK

Size	Industry Offset	True Offset	Bolt Pattern	WPS#
14x7	5+2	+5mm	4/110 12mm Tapered	570-1176
14x7	5+2	+10mm	4/137 12mm Tapered	570-1178
14x7	4+3	+10mm	4/156 12mm Tapered	570-1179
14x7	4+3	4+3	4/156 12mm Tapered	570-1179

WHEEL OFFSET GUIDE

Legend

- █ Hub Face / Wheel Mounting Surface
- | Wheel Center

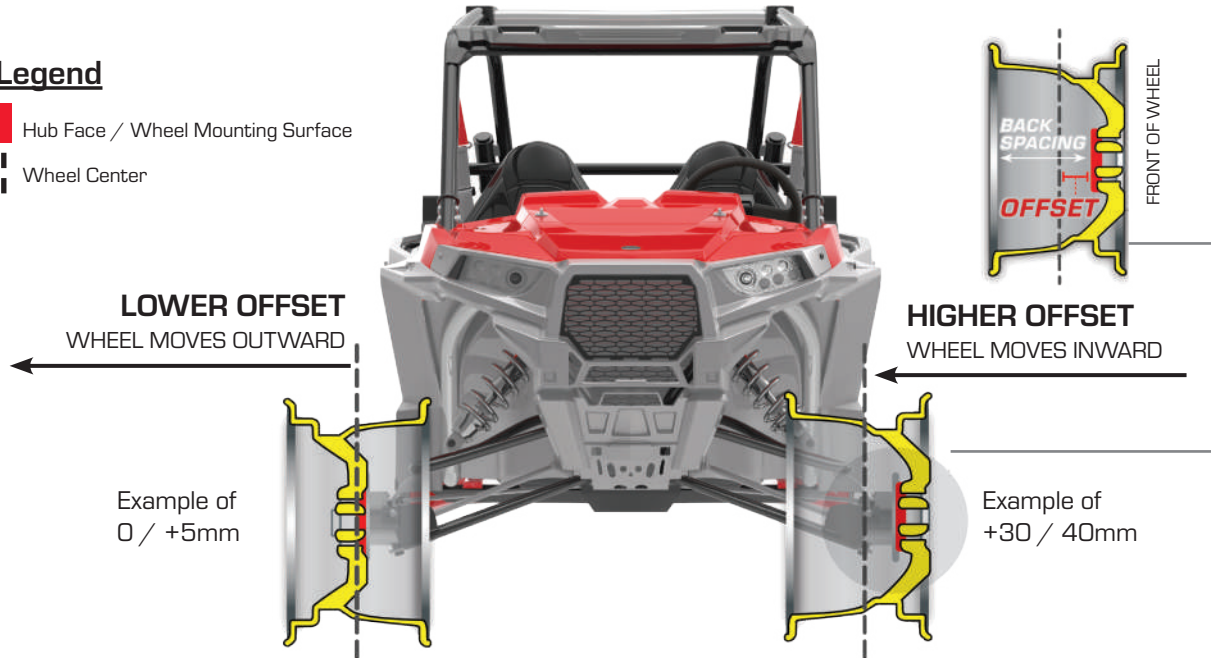

TRUE OFFSET: The measurement from the wheel's mounting surface to the center line of the wheel. This measurement will be stamped in the back of your wheels as ET. ET is another term used to describe wheel offset. Example: -47mm / 0mm / +5mm / +10mm / +30mm / +38mm / +40mm

INDUSTRY OFFSET: Also known as backspacing, is the measurement from the wheel's mounting surface to the back edge of the wheel. In the ATV/UTV world, backspacing measurement generally looks like this... 2+5, 5+2, 4+3 or 6+1 and may not always be exact. This measurement description roughly indicates how much wheel will be on the inside and outside of the Wheel mounting surface.

DISCLAIMER: Please note, offset and or backspacing measurements are determined by the wheel manufacturers. Measurements can vary slightly between wheel brands. This chart is designed to provide you with a general overview and description of wheel offset and or backspacing measurements. Changing from an OE (Original Equipment) offset can cause clearance issues. Check all clearances at all suspension positions before use.

**The information and images above are intended for informational use only. Images may not represent exact measurements.*

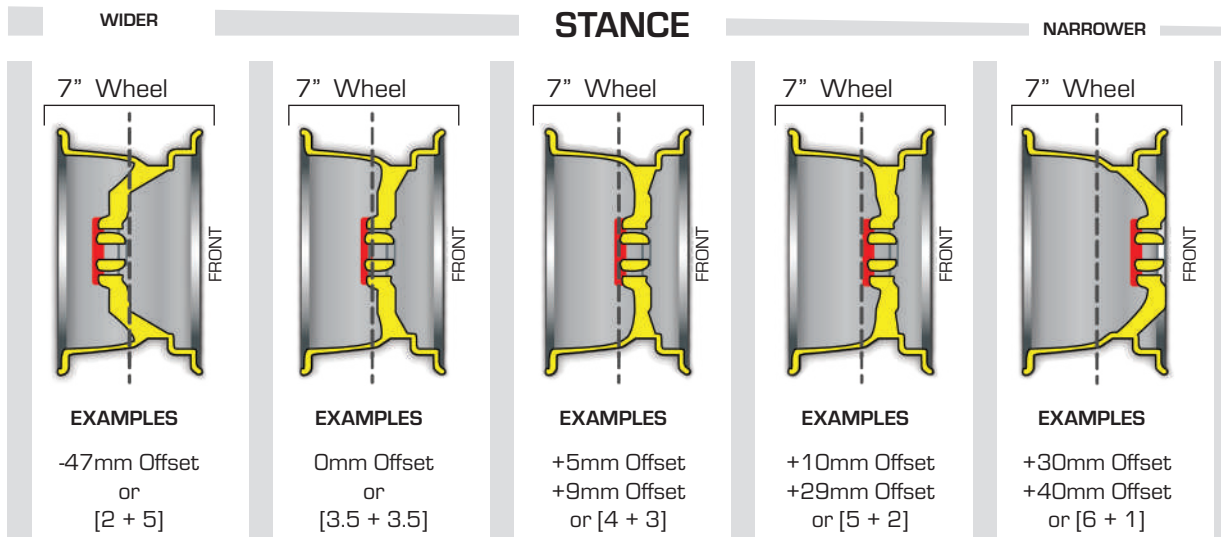



TUBES & ACCESSORIES





STEM TYPE REFERENCE



TR-4



TR-6



TR-13



TR-15

TR-15 Side
(Same as TR-15 at a 45° angle)



TR-87

ATV TUBES



- Great tube at a great price
- Packaged in a heavy-duty box
- Designed to fit perfectly in your tire

Size	Stem	WPS#
145/70-6	TR87	87-0018
16x8.00-7	TR6	87-0020
16x7.50-8	TR13	87-0023
18x9.50-8	TR6	87-0024
20x7.00-8	TR6	87-0026
22x11.00-8	TR6	87-0028

Size	Stem	WPS#
22x11.00-8	TR13	87-0029
22x12.00-8	TR6	87-0027
20x11.00-9	TR6	87-0030
22x11.00-9	TR6	87-0032
25x12.00-9	TR6	87-0034
21x7.00-10	TR6	87-0036
22x8.00-10	TR6	87-0038
22x11.00-10	TR6	87-0040
25x12.00-10	TR6	87-0042
23.5x8.00-11	TR6	87-0044
24x8.00-11	TR6	87-0045
24x9.00-11	TR6	87-0046
24x10.00-11	TR6	87-0047
25x8.00-12	TR6	87-0048
25x10.00-12	TR6	87-0050
25x10.00-12	TR13	87-0051
25x12.00-12	TR6	87-0054
26x12.00-12	TR6	87-0056

HEAVY DUTY TUBES



- T³ (Tapered Tube Technology) Technology offers variable tube thickness to keep weight down and put strength where you need it
- Less unsprung weight and better cooling
- The latest in tube technology
- Built with a high grade synthetic and natural rubber blend
- Heavy 2.5mm outer thickness tapers to a thinner, lighter 1.75mm thickness against the rim

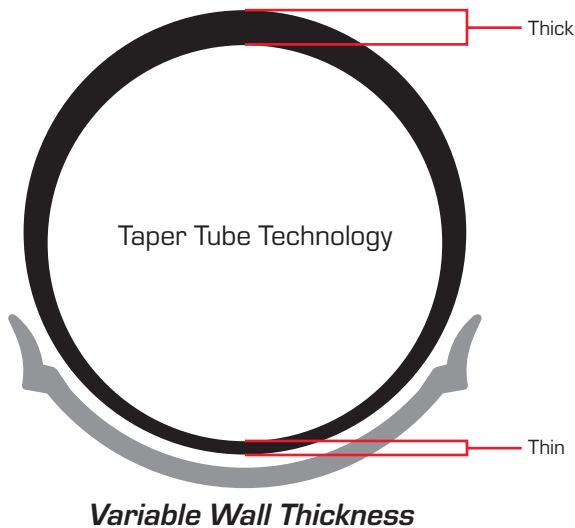

Fits Tire Size	Stem Type	WPS#
2.50/2.75-10 HD	TR-4	87-0310
3.00/3.25-12 HD	TR-4	87-0311
2.75/3.00-14 HD	TR-4	87-0312
2.75/3.00-17 HD	TR-4	87-0356
400/460-17 HD	TR-4	87-0360
4.50/5.10-17 HD	TR-4	87-0362
3.50/4.00-18 HD	TR-4	87-0370
400/460-18 HD	TR-4	87-0372
4.50/5.10-18 HD	TR-4	87-0376
2.50/2.75-19 HD	TR-4	87-0377
100-110/90-19 HD	TR-4	87-0384
110-120/90-19 HD	TR-4	87-0385
2.75/3.00-21 HD	TR-4	87-0386

MOTORCYCLE TUBES



- Constructed of ultra high grade synthetic and natural rubber for long life and pinch resistance
- Strong 2mm thickness
- Top quality at an economical price
- Talcum powder coated for easy installation
- Rigid, attractive box for easy stacking

Fits Tire Size	Stem Type	WPS#
3.50/4.00-17	TR-4	87-0163
4.00/4.50-17	TR-4	87-0159
4.50/5.10-17	TR-4	87-0160
2.25/2.50-18	TR-4	87-0165
2.50/2.75-18	TR-4	87-0164
2.75/3.00-18	TR-4	87-0166
3.25/3.50-18	TR-4	87-0168
3.50/4.00-18	TR-4	87-0170
4.00/4.50-18	TR-4	87-0172
4.50/5.10-18	TR-4	87-0174
5.00/5.10-18	TR-4	87-0176
2.25/2.50-19	TR-4	87-0183
2.50/2.75-19	TR-4	87-0177
2.75/3.00-19	TR-4	87-0178
3.00/3.25-19	TR-4	87-0181
3.25/3.50-19	TR-4	87-0182
100-110/90-19	TR-4	87-0184
100-120/90-19	TR-4	87-0185
90/100-20	TR-6	87-0190
2.75/3.00-21	TR-4	87-0186
3.25/3.50-21	TR-4	87-0188

Fits Tire Size	Stem Type	WPS#
3.00-8	TR-87	87-0099
3.50/4.00-8	TR-4	87-0104
4.00-8	TR-87	87-0090
4.00-8	TR-4	87-0098
2.50/2.75-10	TR-4	87-0110
2.50/2.75-10	TR-87	87-0107
2.75/3.00-10	TR-4	87-0113
2.75/3.00-10	TR-87	87-0109
3.00/3.25-10	TR-87	87-0117
3.50/4.00-10	TR-87	87-0114
3.50/4.00-10	TR-4	87-0115
4.00/4.50-10	TR-87	87-0118
2.50/2.75-12	TR-4	87-0119
3.00/3.25-12	TR-87	87-0121
3.00/3.50-12	TR-4	87-0120
2.25/2.50-14	TR-4	87-0126
2.75/3.00-14	TR-4	87-0128

Fits Tire Size	Stem Type	WPS#
3.25/3.50-14	TR-4	87-0130
3.60/4.10-14	TR-4	87-0131
140/90, 150/90-15	TR-4	87-0140
170/80-15	TR-4	87-0147
2.00/2.25-16	TR-4	87-0193
2.25/2.50-16	TR-4	87-0142
2.75/3.00-16	TR-4	87-0144
3.25/3.50-16	TR-4	87-0146
3.50/4.00-16	TR-4	87-0141
4.00/4.50-16	TR-4	87-0148
5.00/5.10-16	TR-6 side	87-0150
5.00/5.10-16	TR-6	87-0151
2.25/2.50-17	TR-4	87-0154
2.75/3.00-17	TR-4	87-0156
3.00/3.25-17	TR-4	87-0157
3.25/3.50-17	TR-4	87-0158

REPLACEMENT PARTS



LUG NUTS

Application	WPS #
1/2"-20 60° Tapered chrome lug nut 5/8 head (single lug nut)	57-9407
1/2"-20 Splined 60° tapered lug nut w/key box of 16	57-94171
10mm Flat base OEM style lug nut (single lug nut)	57-94125
10mm 60° Tapered OEM style lug nut (single lug nut)	57-9409
3/8"-24 Flat base Chrome lug nut box of 16	57-94137
10mm Flat base OEM style lug nut box of 16	57-94123
3/8"-24 60° Tapered Chrome lug nut 14mm head box of 16	57-9419
3/8"-24 60° Tapered Black lug nut 14mm head box of 16	57-9419B
10mm x 1.25 60° Tapered Chrome lug nut 14mm head (single lug nut)	57-94120
10mm x 1.25 60° Tapered Chrome lug nut 14mm head box of 16	57-94121
10mm x 1.25 60° Tapered Black lug nut 14mm head box of 16	57-94121B
10mm x 1.25 Flat base Chrome lug nut 14mm head box of 16	57-94122
12mm x 1.25 Flat base Chrome lug nut 17mm head box of 16	57-94130
10mm x 1.50 60° Tapered Chrome lug nut box of 16	57-94134
12mm x 1.50 60° Tapered Chrome lug nut box of 16	57-94129
12mm x 1.25 60° Tapered Chrome lug nut 17mm head box of 16	57-94136
12mm x 1.25 60° Tapered Chrome lug nut 14mm head box of 16	57-94138
12mm x 1.50 Splined 60° tapered lug nut w/key box of 16	57-94131
12mm x 1.50 Splined 60° Black tapered lug w/ key box of 16	57-94131B
Replacement key for use with kit 57-94131 and 57-94131B	57-94135
Spike Chrome Lug Nut 3/8"-24 Tapered w/Key	570-0100
Spike Chrome Lug Nut Tapered 10mmx1.25 w/Key	570-0102
Spike Chrome Lug Nut Tapered 12mmx1.25 w/Key	570-0104
Spike Chrome Lug Nut Tapered 12mmx1.50 w/Key	570-0106
Spike Black Lug Nut 3/8"-24 Tapered w/Key	570-0101
Spike Black Lug Nut Tapered 10mmx1.25 w/Key	570-0103
Spike Black Lug Nut Tapered 12mmx1.25 w/Key	570-0105
Spike Black Lug Nut Tapered 12mmx1.50 w/Key	570-0107
Replacement key for use with Spike Lug Nut	570-0110

REPLACEMENT PARTS

Application	WPS #
Beadlock Ring Black 14"	570-1536
Beadlock Ring bolt kit	570-1520
Split 6 Blk/Mac 14" Beadlock Ring	570-1239
Split 6 Black 14" Beadlock Ring	570-1238
Beadlock Plastic Spacer 14"	570-1630S
Beadlock Plastic Spacer 15"	570-1631S

BEADLOCK RINGS



Application	WPS #
4/PK Wheel Inserts - GREY - fits 5+2 / 4+3	570-0013
4/PK Wheel Inserts - GREY - fits 6+1	570-0018
4/PK Wheel Inserts - RED - fits 5+2 / 4+3	570-0014
4/PK Wheel Inserts - RED - fits 6+1	570-0019
4/PK Wheel Inserts - GREEN - fits 5+2 / 4+3	570-0015
4/PK Wheel Inserts - GREEN - fits 6+1	570-0021
4/PK Wheel Inserts - BLUE - fits 5+2 / 4+3	570-0016
4/PK Wheel Inserts - BLUE - fits 6+1	570-0022
4/PK Wheel Inserts - ORANGE - fits 5+2 / 4+3	570-0017
4/PK Wheel Inserts - ORANGE - fits 6+1	570-0020

RUKUS WHEEL INSERTS



REPLACEMENT CENTER CAPS

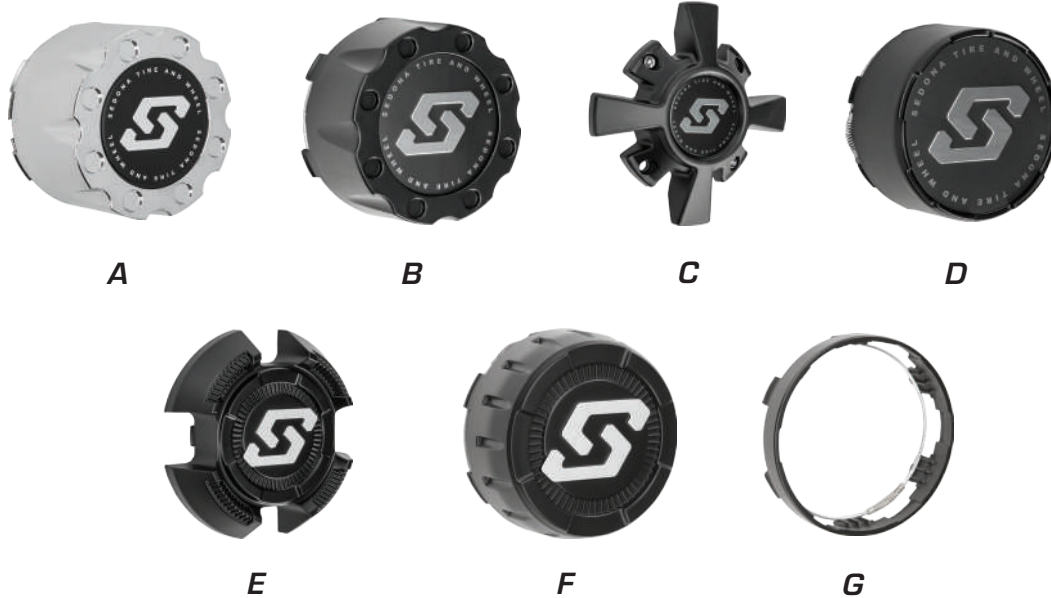

	Application	WPS #
A	Chrome cap 4/137&4/156	570-0002
B	Black Cap - ** fits all Sedona wheels	570-0003
C	Riot Wheel Cap	570-0009
D	Split 6 Center Cap 4/110-4/115	570-0010
	Split 6 Center Cap 4/137-4/156	570-0011
E	Rukus Center Cap - All	570-0012
F	Sparx & Hollow Point Center Cap 4/110	570-0023
	Sparx Hollow Point Center Cap 4/137 - 4/156	570-0024
	Chopper Wheel Center Cap fits all Chopper wheels	570-0026
G	Cap spacer ring for 4/110 bolt pattern for Viking wheels	570-0025

V-BAR ATV/UTV TIRE SNOW CHAINS

Sedona Tire and Wheel V-bar snow tire chains offer the ultimate in traction for icy, snow and muddy conditions. Excellent for plowing applications and winter riding. Available in 4 sizes to accommodate almost every possible ATV/UTV application. The all new "D" size works great for the newer oversized tires on today's larger ATV/UTVs.

- Offers "Ultra-Traction" with V-Bar cleats
- V-Bar cleats are hardened steel for extended life
- Installation hooks keep chains snug and secure
- Packaged in a durable storage bag for easy storage
- Optional chain bungee # 61-4720 available to insure chain tension for dependable and consistent traction on snow and ice

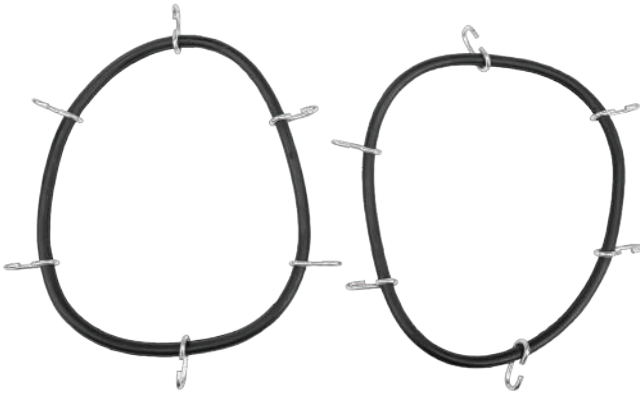

WPS #	Size	Description	Fitment
61-4716	"A"	8 V-Bars per cross section	Fits: 21x10x8, 22x11x9, 22x10x10
61-4717	"B"	9 V-Bars per cross section	Fits: 22x11x10, 22x10x12, 25x8x12
61-4718	"C"	10 V-Bars per cross section	Fits: 25x12x9, 25x11x10, 26x10x12
61-4719	"D"	11 V-Bars per cross section	Fits: Oversize Tires (most 27" and 28" tires)
61-4720	BUNGEEES		ALL



SEDONA
TIRE AND WHEEL

Learn more about powersports wheels and tires we have.