

Installation & Operations Manual Armory X Rack- Full Size Ranger

Patent Pending



Installation information:

- This product has an installation rating of: **Easy**
- Approximate installation time: **30 Minutes**
- This product is easiest to install with: **2 people**

Seizmik makes Windshields, Doors, Tops, Hood Racks, Brush Guards, and other great accessories for utility vehicles & side x sides. Our products are engineered tough for long life and tested under the harshest of conditions.

Always observe the warnings and precautions in this manual when using your Seizmik products. For best results, carefully follow the instructions in this manual and make no modifications.

Parts List

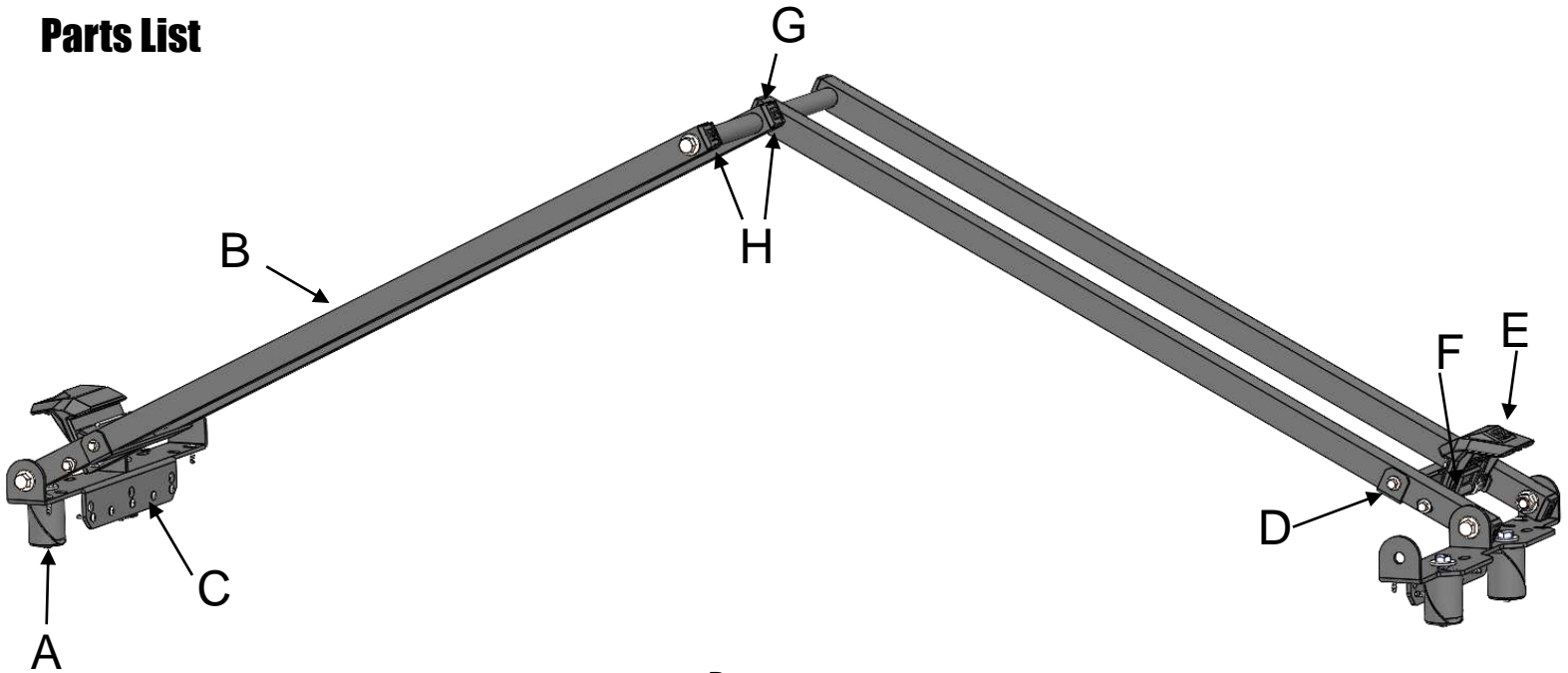

Parts:

- A. Wedge Bolt Assembly (4)
- B. Gun Rail Assembly (2)
- C. Base Plate (2)
- D. Spring Plate (2)
- E. Paddle Latch (2)
- F. Paddle Latch Spring (2)
- G. Top Spacer
- H. End Caps (8)

Hardware:

- (1) M10 350mm Flange Head Bolt
- (2) M6 175mm Flange Head Bolt
- (4) M10 40mm Hex Head Bolt
- (4) M8 60mm Hex Head Bolt
- (4) M6 40mm Flange Head Bolt
- (5) M10 nylock nut
- (6) M6 Flange nylock nut
- (5) M10 Washer
- (4) M8 Washer

X Rack Assembly

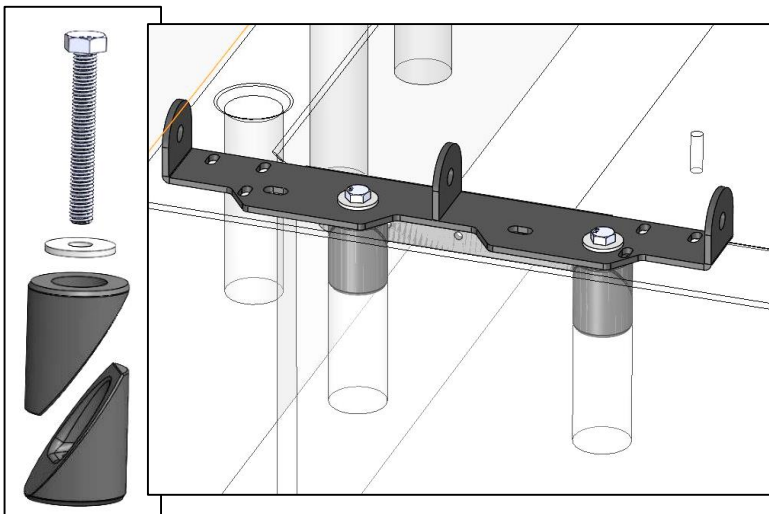

1. Install 2 Wedge bolt assemblies (A) per side of the bed using included M8x60mm bolts. Use the forward most lock and ride holes as shown above and tighten down until the plate is secure in the bed side.

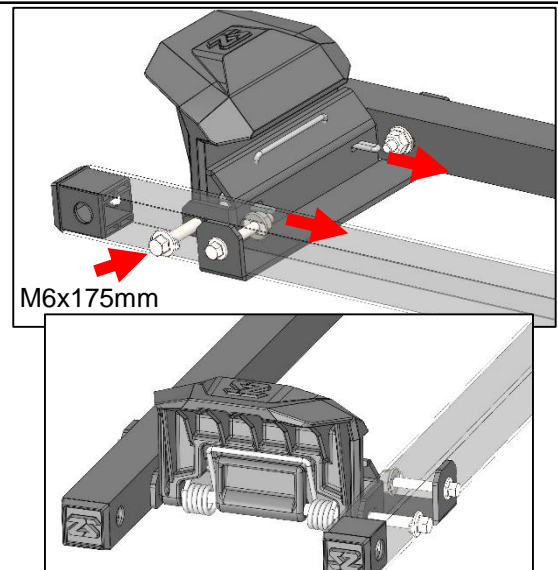

2. The Gun Rail Assembly should be loosely bolted together as shown above using an M6x175mm bolt and 2 M6x35mm bolts. The Spring Plate (D) slides forwards and backwards to ensure every gun case fits securely in the rails. Make sure the assembly slides forwards and backwards easily, it will be adjusted in step 7.

X Rack Assembly

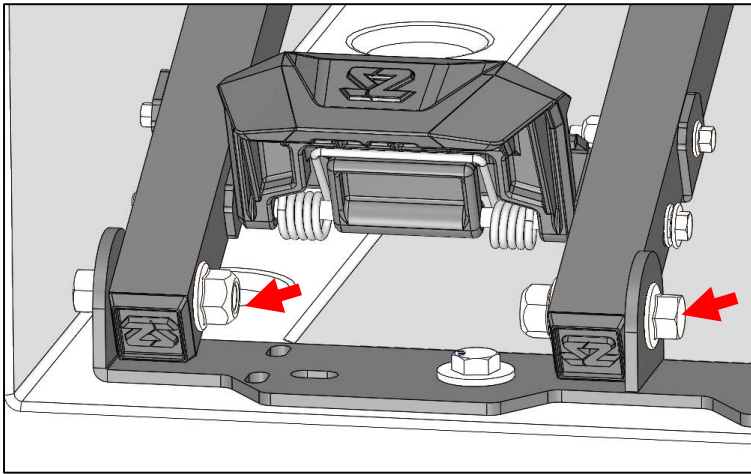

3. Loosely bolt the gun rail assembly to the base plate using 2 M10x40mm bolts and flange nuts per side. The driver side rail should be mounted in the forward most position while the passenger side rail should be mounted in the rearward position so that the rails may be bolted together at the top. Do not tighten down at this point.

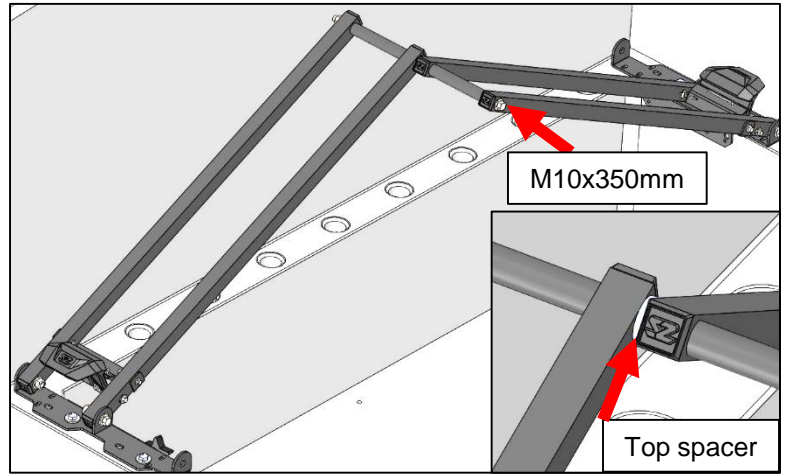

4. Pivot the Gunrails (B) upward and bolt together as shown using the M10x350mm flange bolt and locking flange nut. Be sure to place the Top Spacer (G) in between the Gunrails (B) to maintain proper alignment. Tighten the M10x350mm bolt until snug. Over tightening may cause square tubing to deform.

Armory SST Installation and Adjustment

At this point, the Armory SST Gun Case must be placed in the rack and the spring plate(s) (D) must be adjusted.

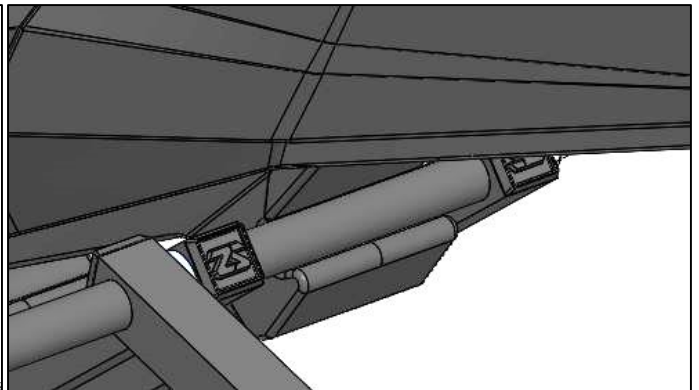
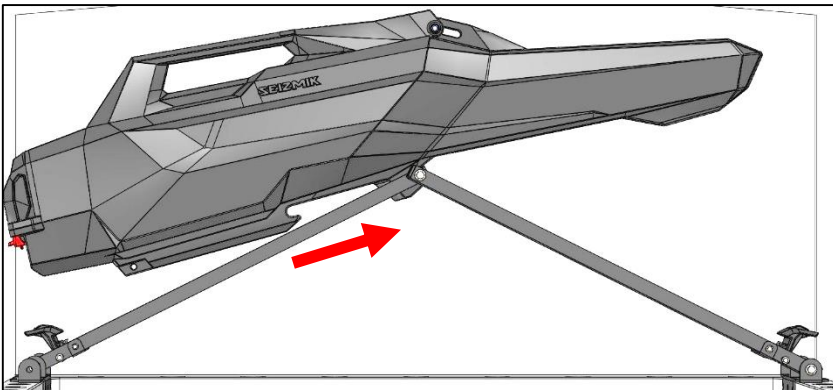

5. Using the front hook of your Armory SST Gun Case, capture the upper tubing of the Gun rail pushing firmly to ensure full engagement.

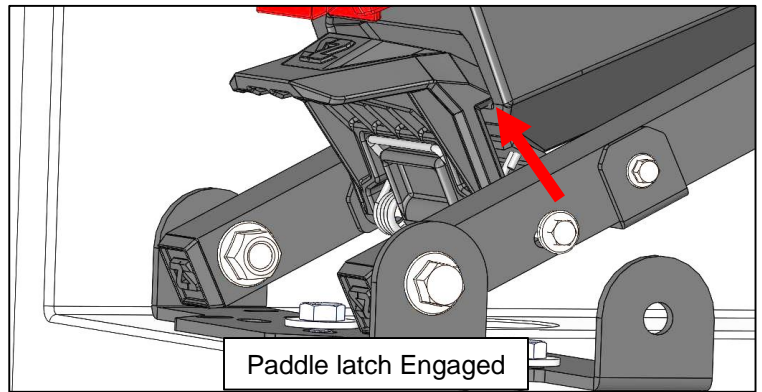
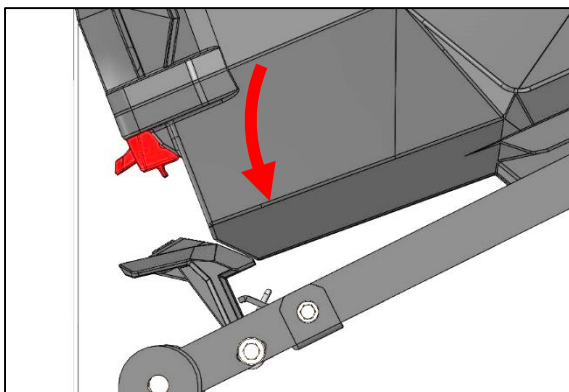

6. While keeping the front hook engaged, pivot the rear of the Armory SST Gun Case downward and push firmly to move and snap the paddle latch (E) into place.

Armory SST Installation and Adjustment

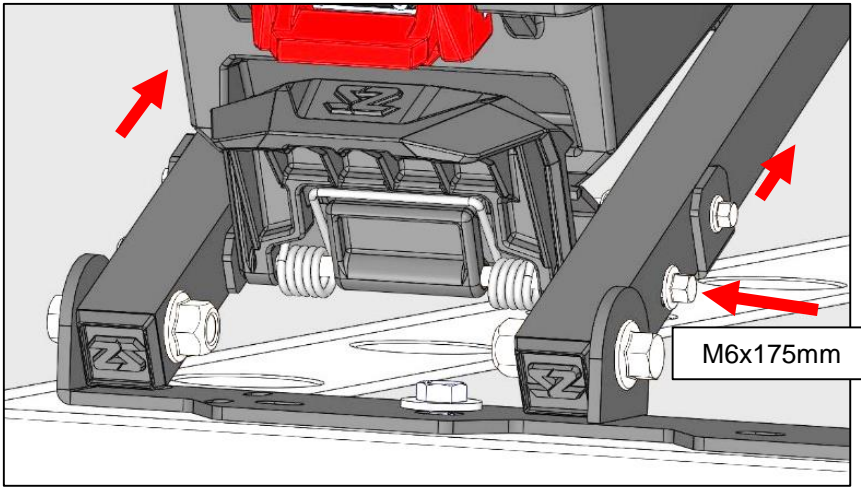

7. To ensure the Armory SST Gun Case is secure in the X Rack, push the spring plate assembly (Should still be only loosely bolted in) forward into the rear of the gun case so that the paddle latch is fully engaged and that the case does not rattle or move around. With the Spring plate assembly pushed forward, tighten down the M6x175mm Flange bolt snugly so that the spring plate does not slide away from the gun case.

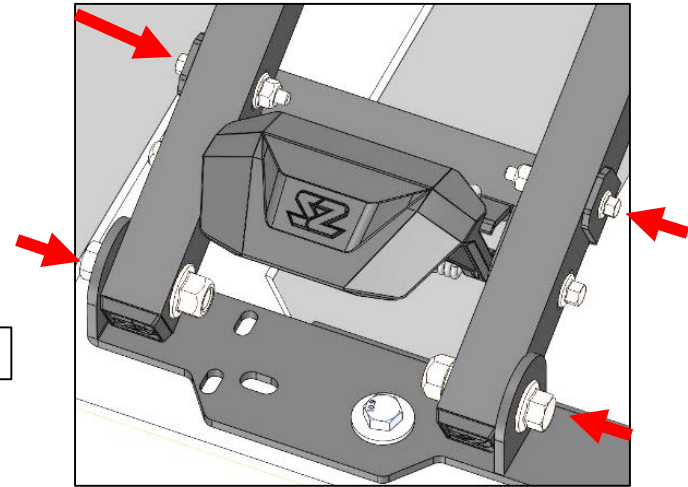

8. At this point, remove the gun case from the X rack making sure you don't move the spring plate upon removal. With the gun case out of the rack, snug down the other 2 M6x35mm flange bolts and locking nuts. You may now also snug down the 2 M10x40mm bolts at this time. Do not over tighten. Over tightening may cause square tubing to deform.



Armory X Rack Shown with 1 Armory SST Gun Case



Armory X Rack Shown with 2 Armory SST Gun Cases

Congratulations – You have now finished the installation of your Seizmik Armory X Rack.

Features include:

- Rack holds up to 2 gun cases (sold separately)
- Heavy gauge steel frame holds gun cases steady under tough conditions
- Spring loaded binding for quick and secure case load and release
- Thick steel mounting plate installs quickly and easily
- Designed specifically for UTVs with safety in mind—gun barrels are kept facing up and away from users

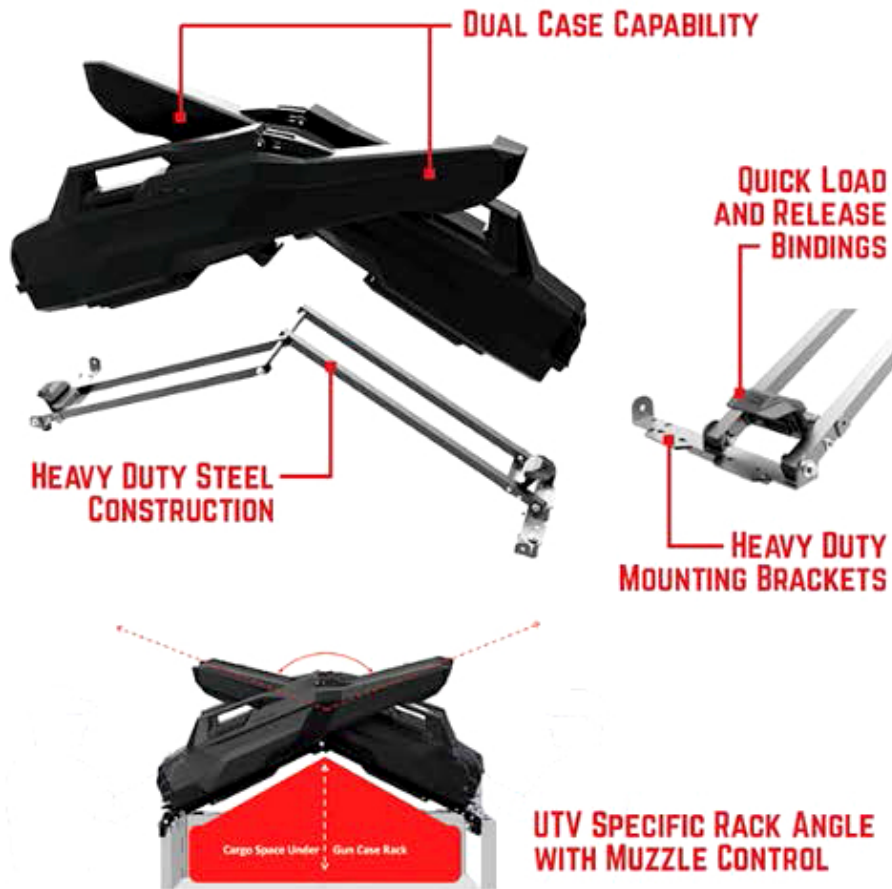

PART #	FITMENT
07101	Full Size Ranger - works with Lock & Ride®
07102	Mid Size Ranger-works with Lock & Ride®, or drill and bolt in for Mid Size Gator, Pioneer 700, beds 44"- 48"†
07103	Kubota RTV X, beds 55"- 58"† - drill & bolt in
07104	Pioneer 1000, Pro Mule, Defender, beds 51.5"-55.5"† - drill & bolt in
07105	John Deere Full Size Gator - clamps attach to bed rails or drill and bolt in to steel beds

Find out more about luggage systems & organizers we have.