

## Installation Manual RZR PRO XP Rear Windshield Panel

Part Number  
Uncoated Poly#26104  
Hard Coated Poly #26105



### Kit Contents:

1. Upper Windshield
2. Lower Windshield
3. 13.25" 90-degree Bulb Gasket (2)
4. 49" 90-degree Bulb Gasket
5. 63" 180-degree Bulb Gasket
6. 1.75" Plastic Clamp (2)
7. Bracket (4)
8. Bracket Cover (8)
9. 6mm Flat Washer (14)
10. 6mm Hex Flange Nut (14)
11. 6x30mm Socket Button Head Cap Screw (14)

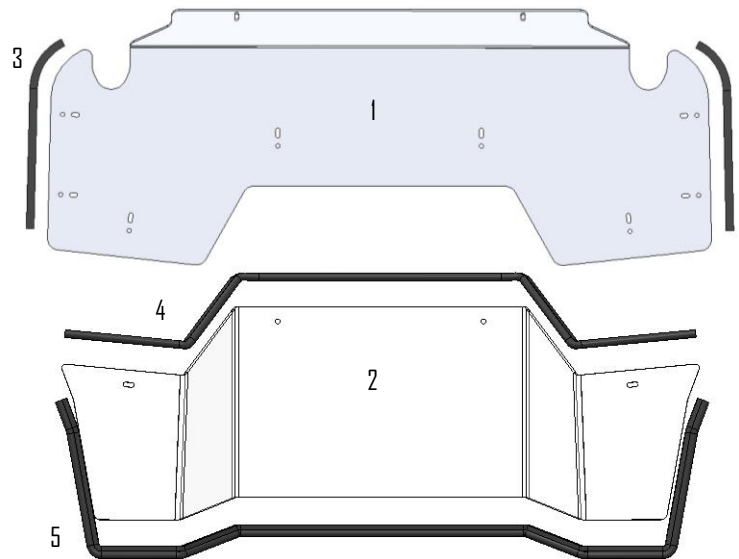
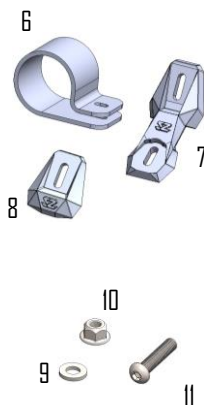

### Installation Information:

This product does not require any modifications to your vehicle. Please familiarize yourself with all the steps before beginning assembly.

### Compatibility Info:

This windshield is designed to work with other Seizmik branded Accessories for the RZR PRO XP as well as OEM Polaris hard tops. Please note Seizmik cannot guarantee fitment with other branded aftermarket products. Please research installation details on our products and others when trying to combine different branded accessories.

Seizmik makes Windshields, Mirrors, Door Kits, Light Bars, Hood Racks, and other great accessories for UTV's to maximize the vehicles usefulness. To help you do what you do better.

# Installation:



1. Peel plastic 4" back on edges of windshield. Remove completely after windshield is fully installed.

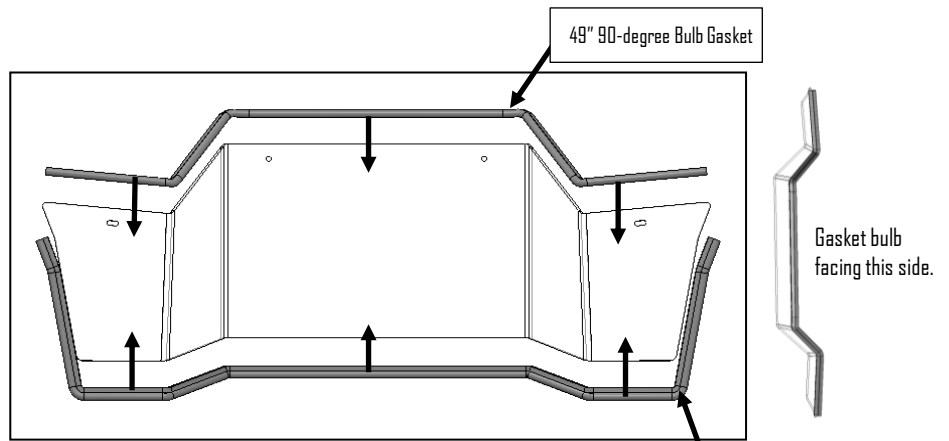

2. Push 49" 90-degree bulb gasket onto lower windshield with the bulb section oriented as shown. Push 63" 180-degree Bulb Gasket onto lower windshield.

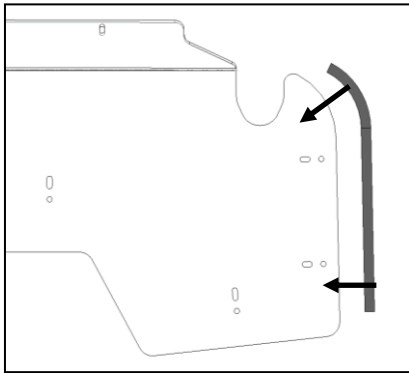

3. Push the 13.25" gaskets on the upper windshield with the bulb section oriented as shown.

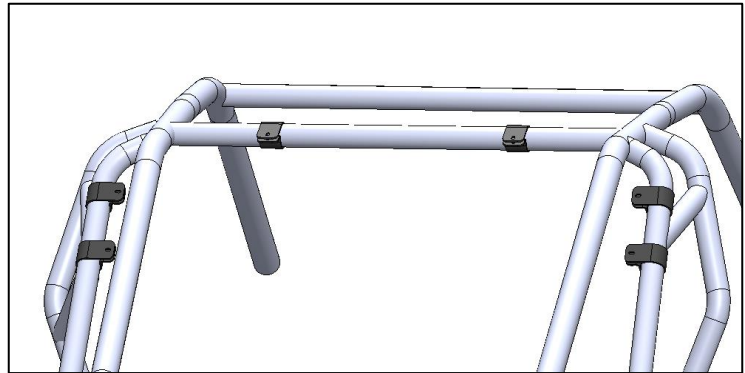

4. Place clamps on roll cage in approximate locations shown. Be careful not to pinch fingers.

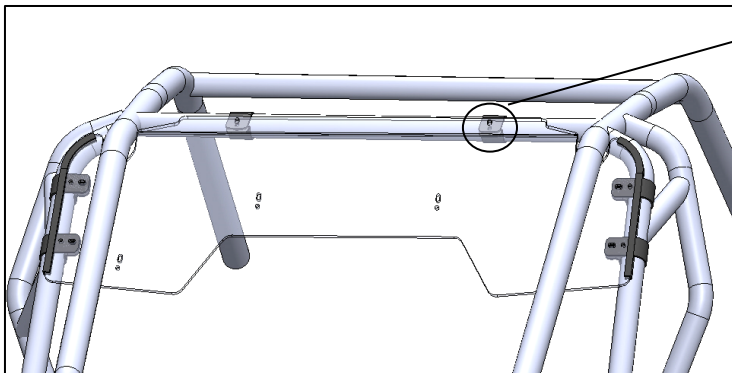

5. Place upper windshield in location shown. Gasket bulb should be against roll cage.

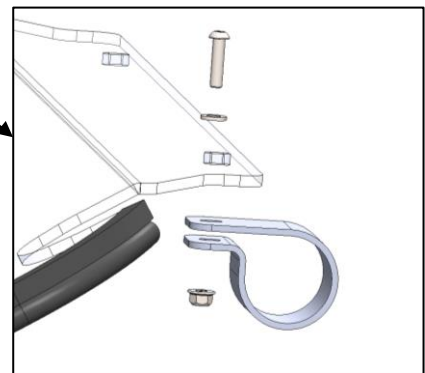

6. Insert bolt through washer and windshield, loosely install nuts on both top clamps.

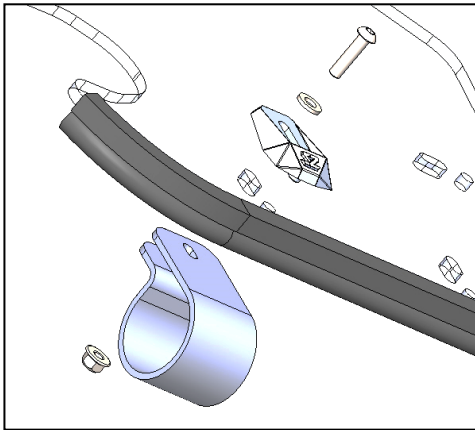

**7.** Insert bolt through washer, bracket cover, and windshield, loosely install nuts on 4 side clamps.

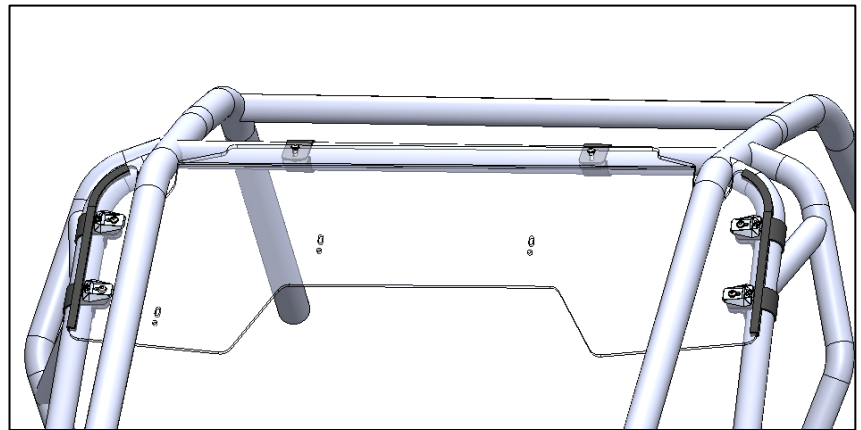

**8.** Once all clamps are loosely attached it should look like this.

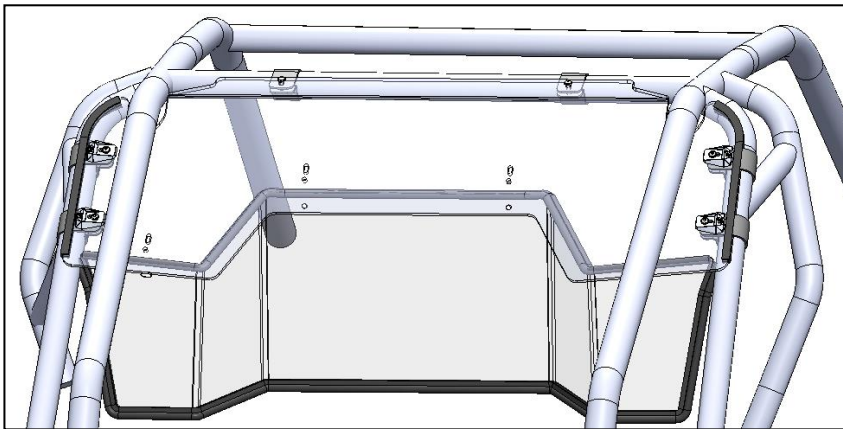

**9.** Insert lower windshield. It should fit snugly against rear speakers, behind seat belt, and against upper windshield.

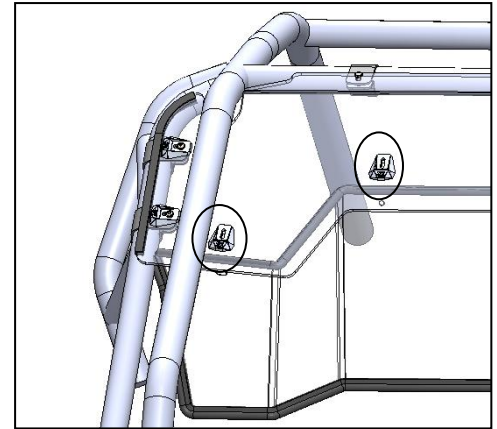

**10.** Place 4 remaining bracket covers on upper windshield as shown.

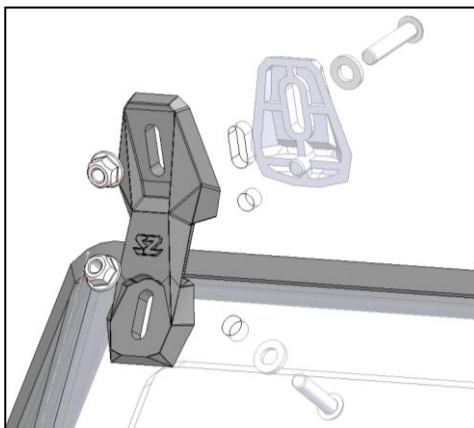

**11.** Use brackets to connect upper and lower windshield. Insert bolt through washer, bracket cover, and windshield and loosely install nuts on all 4 brackets. Only top bolt has bracket cover.

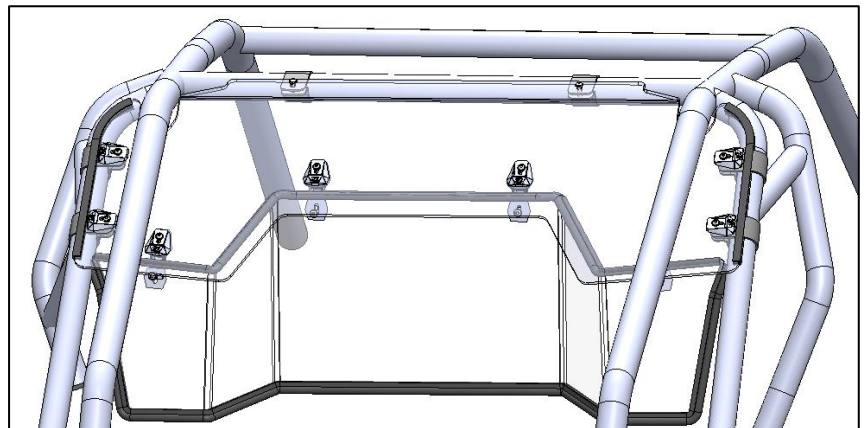

**12.** The bracket slots allow for adjustment in the lower windshield so that you may ensure the windshield gasket seals along bottom edge. Make sure windshield is centered and snug, tighten all bolts.