



Installation Information:

This product does not require drilling or modifications to the vehicle. Please familiarize yourself with all the steps before beginning assembly.

Compatibility Info:

This windshield is designed to work with other Seizmik branded Accessories for the Can Am Defender as well as OEM Can Am branded hard tops. Please note Seizmik cannot guarantee fitment with other branded aftermarket products. Please research installation details on our products and others when trying to combine different branded accessories.

Seizmik makes Windshields, Mirrors, Cab Systems, Light Bars, Storage Boxes, Hood Racks, and other great accessories for UTV's to maximize the vehicles usefulness. To help you do what you do better.

Kit Contents:

1. Folding Windshield with stiffening rib
2. Bulb Gasket
3. Pro-fit Windshield Lever Assembly (2)
4. Windshield Holder Assembly (3)
5. Pro-fit Windshield Clamp assembly (2)

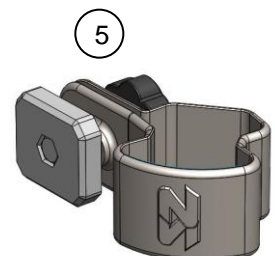
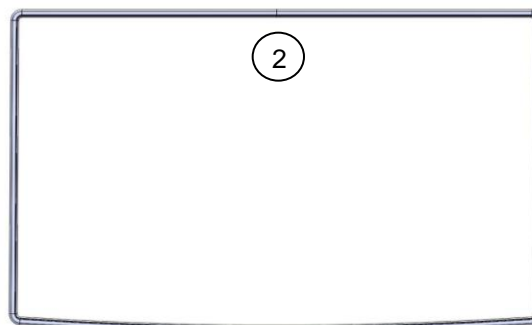
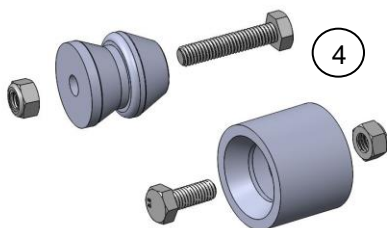
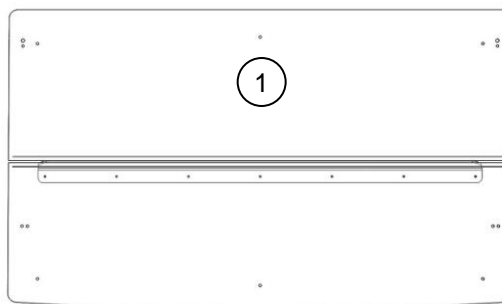



1. Peel the plastic film back from all edges and holes of the windshield before beginning. Remove after windshield is fully installed.

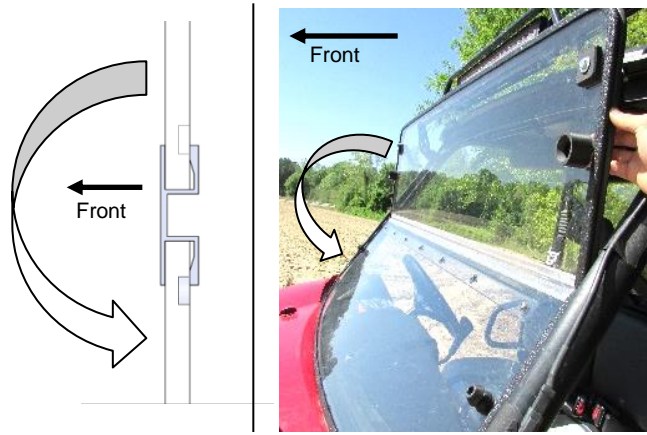

2. **NOTE: The orientation of gasket and parts are very important. See above.** The hinge will ONLY allow the windshield to fold down flat in one direction. You may find it helpful to place a piece of tape marking the front side to avoid confusion in the following steps.

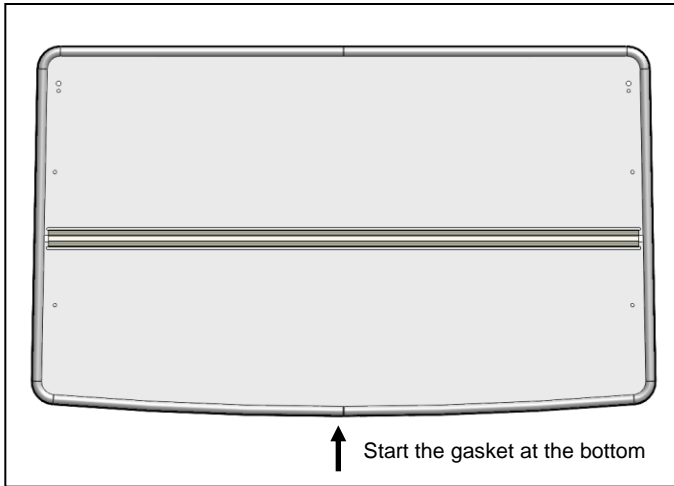

3. Attach the weather strip by pressing the channel in the gasket onto the windshield with the bulb facing the **BACK** of the windshield. The gasket will seal between the windshield and the vehicle. Start the gasket at the middle of the bottom windshield.

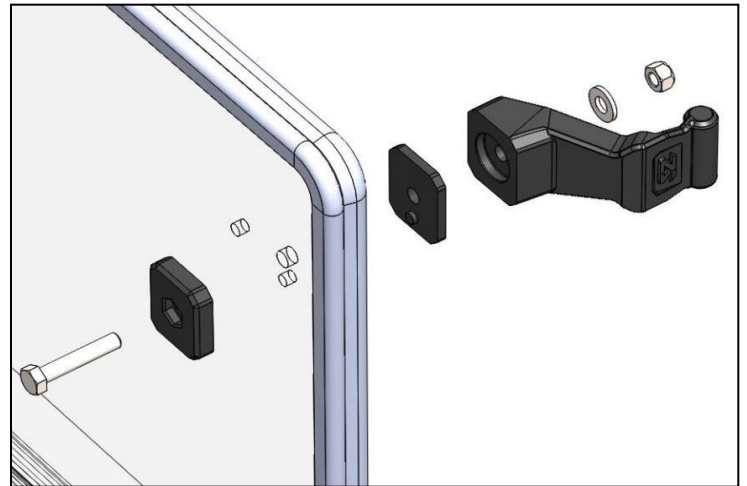

4. Assemble a windshield lever in the upper corner of the windshield using the two holes closest to the edge as shown. The levers will be on the **INSIDE** of the windshield. Tighten the nut so that the levers require a slight amount of force to turn them. Repeat for the other side.

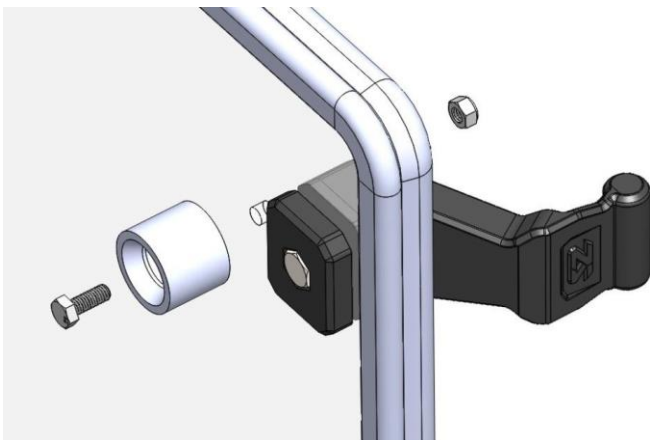

5. Assemble the female portion of the windshield holder in the upper corner hole next to the lever as shown on the **FRONT** of the windshield. Repeat for the one in the center and other side.

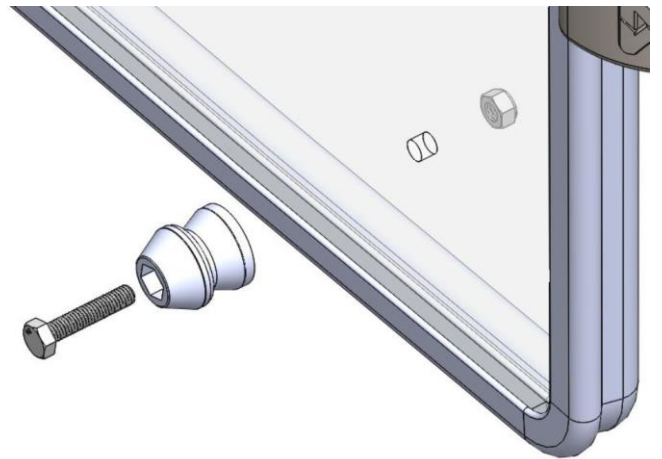

6. Assemble the male portion of the windshield holder in the lower corner hole as shown on the **FRONT** of the windshield. Repeat for the one in the center and other side.



7. Attach the pro-fit roll cage clamps to the vehicle in the approximate location shown.

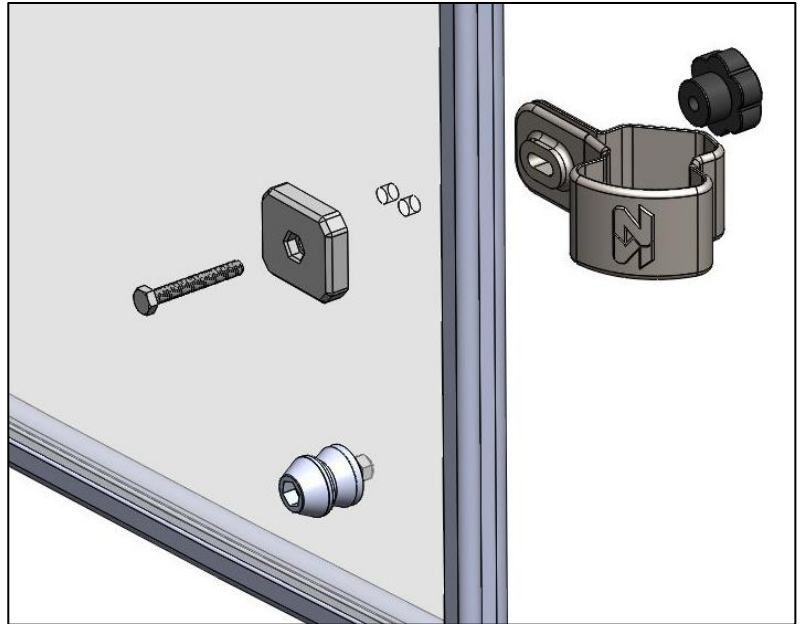

8. Attach the windshield as shown. Before tightening the knobs, adjust the position of the unfolded windshield in the roll cage so that the gaps are the same on both sides and that there is enough gap at the tip for it to fold easily. When you are happy with the position, tighten the knobs.

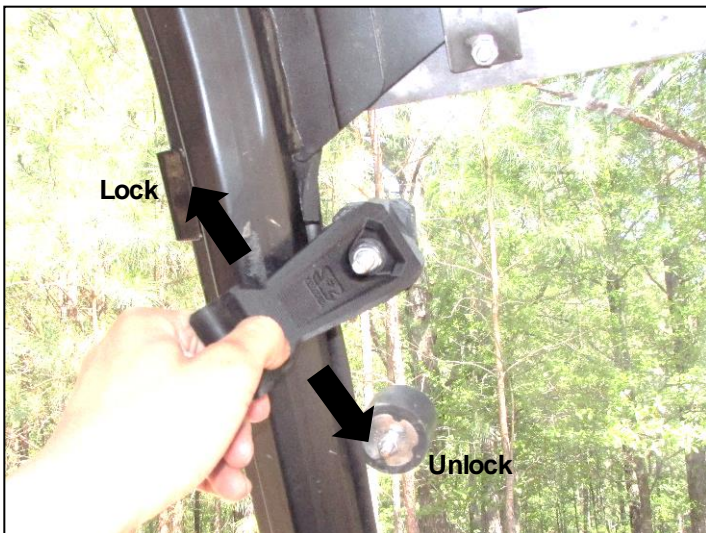

15. Rotate both levers perpendicular to the roll cage to lock the windshield in place. To release the top section of the windshield, rotate the lever 90°.



16. Push the top half of the windshield down and firmly press the rubber plugs against each other to lock windshield in down position. (Your vehicle may not be the same as the photo but they work the same).