



Winch Packing List

DESCRIPTION	QUANTITY
1. Winch Assembly with Wire Rope	1
2. Cap Bolt M8* 30	2
3. Lock Washers	2
4. Flat Washers.....	2
5. M8 Nuts.....	2
6. Clevis Hook w/Pin	1
7. Handle Bar Control	1
8. Strap	1
9. Remote.....	1
10. Winch Plate.....	1
11. Solenoid.....	1

Warnings and Cautions



As you read these instructions, you will see WARNINGS, CAUTIONS, NOTICES and NOTES.

Each message has a specific purpose. WARNINGS are safety messages that indicate a potentially hazardous situation, which, if not avoided could result in serious injury or death. CAUTIONS are safety messages that indicate a potentially hazardous situation which, if not avoided, could result in minor or moderate injury. A CAUTION may also be used to alert against unsafe practice. CAUTIONS and WARNINGS identify the hazard, indicate how to avoid the hazard, and advise of the probable consequence of not avoiding the hazard. NOTICES are messages to avoid property damage. NOTES are additional information to help you complete a procedure. **PLEASE WORK SAFELY!**



MOVING PARTS ENTANGLEMENT HAZARD

Failure to observe these instructions could lead to severe injury or death. To avoid injury to hands or fingers:

- **Always** keep hands clear of rope, hook loop, hook and fairlead opening during installation, operation and when spooling in or out.
- **Always** use extreme caution when handling hook and rope during spooling operations.
- **Always** use supplied hook strap whenever spooling rope in or out, during in stallation, and during operation.
- **Always** keep vehicle in sight during winching operation.
- **Always** wear heavy leather gloves when handling rope.



CHEMICAL AND FIRE HAZARD

Failure to observe these instructions could lead to severe injury or death.

- **Always** remove jewelry and wear eye protection.
- **Never** lean over battery while making connections.
- **Always** verify area is clear of fuel lines, fuel tank, brake lines, electrical wires, etc.

When drilling.

- **Never** route electrical cables:
 - Across any sharp edges.
 - Through or near moving parts.
 - Near parts that become hot.
- **Always** insulate and protect all exposed wiring and electrical terminals.
- **Always** install terminal boots as directed in installation instructions.



MOVING PARTS ENTANGLEMENT HAZARD

Failure to observe these instructions could lead to minor or moderate injury.

- **Always** keep wired remote control lead clear of the drum, rope and rigging. Inspect for cracks, pinches, frayed wires or loose connections. Replace remote control if damaged.
- **Always** pass wired remote control through a window to avoid pinching lead in door, when using remote inside a vehicle.
- **Never** leave remote control where it can be activated during freespooling, rigging, or when the winch is not being used.
- **Always** require operator and bystanders to be aware of vehicle and or load.

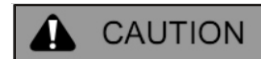

MOVING PARTS ENTANGLEMENT HAZARD

Failure to observe these instructions could lead to minor or moderate injury. General Safety:

- **Always** know your winch. Take time to fully read the Installation Guide and the Basic Guide to Winching Techniques in order to understand your winch and its operation.
 - **Never** operate this winch if you are under 16 years of age.
 - **Never** operate this winch when under the influence of drugs, alcohol or medication.
 - **Never** exceed winch or rope capacity listed on product data sheet. Double line using a snatch block to reduce winch load.
- Installation Safety:
- **Always** choose a mounting location that is sufficiently strong to withstand the maximum pulling capacity of your winch.
 - **Always** use factory approved mounting hardware, components, and accessories.
 - **Always** use grade 5 (grade 8.8 metric) or better mounting hardware.
 - **Never** weld mounting bolts.
 - **Always** use care when using longer bolts than those supplied from factory. Bolts that are too long can damage the base and/or prevent the winch from being mounted securely.



- **Always** mount the winch and attach the hook to the rope's end loop before connecting the electrical wiring.
- **Always** spool the rope onto the drum in the direction specified by the winch warning label on the winch and/or documentation. This is required for the automatic brake (if so equipped) to function properly.
- **Always** prestretch wire rope and respool under load before use. Tightly wound wire rope reduces chances of “binding”, which can damage the rope.



MOVING PARTS ENTANGLEMENT HAZARD

Failure to observe these instructions could lead to minor or moderate injury.

- **Always** inspect, rope, hook, and slings before operating winch. Frayed, kinked or damaged rope must be replaced immediately. Damaged components must be replaced before operation. Protect parts from damage.
- **Never** leave remote control plugged into winch when free spooling, rigging, or when the winch is not being used.
- **Never** hook rope back onto itself. This damages the rope.
- **Always** use a choker chain, choker rope, or tree trunk protector on the anchor.
- **Always** remove any element or obstacle that may interfere with safe operation of the winch.
- **Always** take time to use appropriate rigging techniques for a winch pull.
- **Always** be certain the anchor you select will withstand the load and the strap or chain will not slip.
- **Never** engage or disengage clutch if winch is under load, rope is in tension or drum is moving.
- **Always** select an anchor point as far away as possible. This will provide the winch with its greatest pulling power.
- **Never** winch with less than 5 wraps of rope around the drum. The rope could come loose from the drum.
- **Never** touch rope or hook while in tension or under load.
- **Never** touch rope or hook while someone else is at the control switch or during winching operation.
- **Always** stand clear of rope and load and keep others away while winching.
- **Always** be aware of stability of vehicle and load during winching, keep others away. Alert all bystanders of any unstable condition.
- **Never** use winch to secure a load.

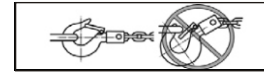

MOVING PARTS ENTANGLEMENT

HAZARD

Failure to observe these instructions could lead to minor to moderate injury.

- **Always** use a hook with a latch
- **Always** insure hook latch is closed and not supporting load.
- **Never** apply load to hook tip or latch. Apply load only to the center of hook.
- **Never** use a hook whose throat opening has increased, or whose tip is bent or twisted.



FALLING OR CRUSHING HAZARD

Failure to observe these instructions could lead to severe injury or death.

- **Never** use winch to lift or move persons.
- **Never** use winch as a hoist or to suspend a load.

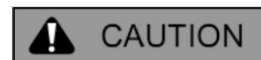

CUT AND BURN HAZARD

Failure to observe these instructions could lead to minor or moderate injury.

To avoid injury to hands and fingers:

- **Always** wear heavy leather gloves when handling a rope.



- **Never** let rope slip through your hands.
- **Always** be aware of possible hot surface at winch motor, drum or rope during or after winch use.

NOTICE

AVOID WINCH AND EQUIPMENT

DAMAGE

- **Always** avoid side pulls which can pile up rope at one end of the drum. This can damage rope or winch.
- Always ensure the clutch is fully engaged or disengaged.
- Never use winch to tow other vehicles or objects. Shock loads can momentarily exceed capacity of rope and winch.
- Always avoid “powering out” for extended distances. This causes excess heat and wear on the winch motor and brake.
- Always use care to not damage the vehicle frame when anchoring to a vehicle during a winching operation.
- Never “jog” rope under load. Shock loads can momentarily exceed capacity of rope and winch.
- Never use winch to secure a load during transport.
- Never submerge winch in water.
- Always store the remote control in a protected, clean, dry area.
- Always double line or pick distant anchor point when rigging. This maximizes pulling power and avoids overloading the winch.

CAUTION

To prevent accidental activation of the winch and serious injury, complete the winch installation and attach the hook before installing the wiring.

Safety

When installing your ATV winch system, read and follow all mounting and safety instructions. Always use caution when working with electricity and remember to verify that no exposed electrical connections exist before energizing your winch circuit. For specifications and performance data, refer to the specification sheet supplied with your winch.

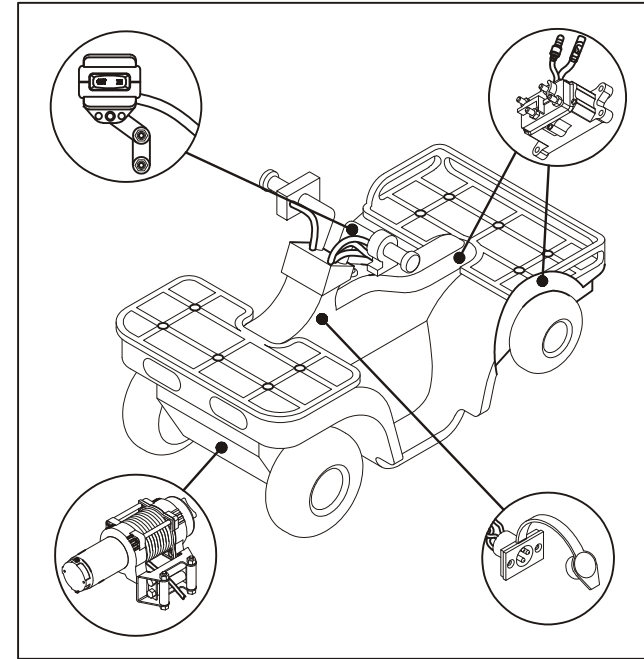

Figure 3: To install the complete kit, you will need to mount the winch, contactor handlebar mounted Mini-rocker switch and remote socket (optional on some models).

Step 1 - Mount the Winch

To secure the winch, always use:

A flat, secure mounting location at least 4.8 mm (3/16 in.) thick.

Lock washers.

Hex head cap screws when using a one-piece winch mount plate.

Note: When using separate winch mount and fairlead plates use hex head capscrews on the motor side of the base as shown in Figure 4.

Torque the mounting bolts to 16 N-m (12 lb-ft)

Remove bottom tie bolt. This bolt should be retained for winch service.

Attach the clevis hook to the wire rope.

Put clutch in freespool position.

Manually feed cable loop through fairlead.

- Attach hook to cable loop and re-engage clutch.

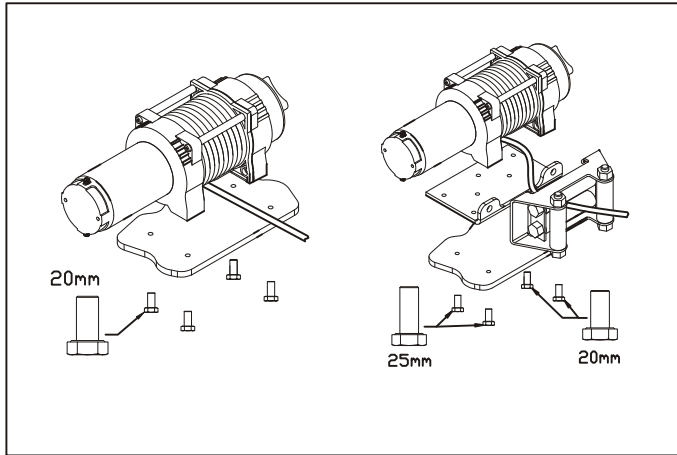

Figure 4: Orientation of winch to, mounting plate and bolt lengths.

Step 2 - Mount the Contactor or Control Box

The contactor is a primary safety feature in your winch system. It disconnects your winch from its power source when the ATV is not in use. The contactor must be correctly installed to work properly.

It is recommended that the contactor be mounted close to the battery and in a location that is as clean and dry as possible. Exact location will vary, depending on the ATV. Usual locations include inside, on top, or on the side of rear storage box, and on a few models, under the seat.

Ensure the contactor mounting location selected provides sufficient clearance from all metal structures such as frame tubes. Do NOT place tools or other items in a position that might come in contact with the contactor directly.

Drill the mounting holes for the contactor at this time, then move on to step four as it will be easier to attach all the wiring to the contactor before attaching it to the ATV. Do NOT mount the contactor at this time.

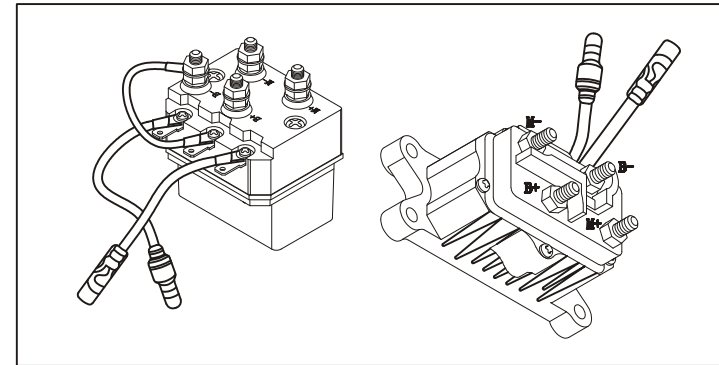
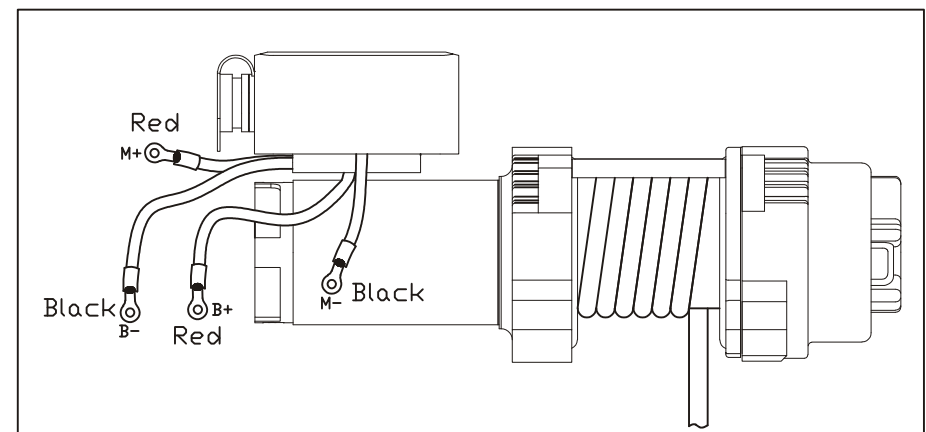

Figure 5. Contactors for ATV winch

NOTE: Install the control box

Mount the control box on winch.

Connect the short red cable marked “M+” to the “+” terminal of the motor.
 Connect the short black cable marked “M-” to the “-” terminal of the motor.
 Connect the long red cable marked “B+” to the “+” terminal of the battery.
 Connect the long black cable marked “B-” to the “-” terminal of the battery.





Step 3- Mount the Handlebar Switch

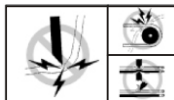

TO PREVENT SERIOUS INJURY OR DEATH FROM ELECTRICAL FIRE:

- Do NOT route electrical cables across sharp edges.
- Do NOT route electrical cables through or near moving parts.
- Do NOT route electrical cables through or near any high heat parts.
- Avoid pinch and wear/abrasion points when installing all electrical cables.

TO AVOID INJURY AND PROPERTY DAMAGE:

- Use caution when moving or repositioning any vehicle controls so as to not compromise the safe operation of the ATV. Select a mounting position that will provide clearance for all vehicle controls.
- Before securing the switch cable with tie wraps, make sure that the handlebars have full range of motion.

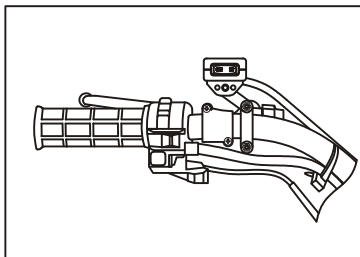

Figure 6: handlebar mount.
assembly Exact positioning may vary depending on ATV make and model.

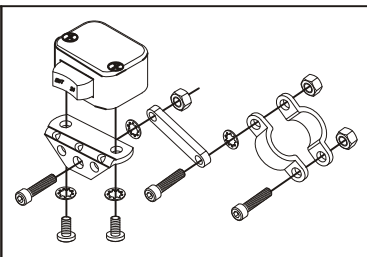

Figure 7: Mini-rocker switch

- It is recommended that the switch be installed on the left handlebar. A piece of electrical tape around the handlebar will help prevent rotation of mount on the handle bar.
- Do NOT tighten over any hoses or cables.
- Once the handle bar switch is mounted, route the two bullet terminal wires back to where the contactor will be mounted. Splice the end of the red wire to a key controlled accessory circuit of the ATV (use the provided wire splice). Using a test light, locate a suitable wire from the ATV key switch. The wire should only have power when the key is in the "ON" position.

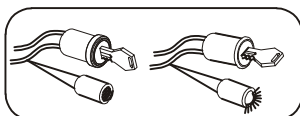

Figure 8: Use a test light to locate a suitable wire



Step 4 - Mount the Connector for Remote



TO PREVENT SERIOUS INJURY OR DEATH FROM EXPLOSION:

- Do NOT drill into gas tank.
- Verify the area is clear behind the mounting location before drilling.
- After determining the mounting location for the remote socket, drill three holes and install. (see figure 9)
- Once the remote socket is mounted, route the two bullet terminal wires back to where the contactor will be mounted. Splice the end of the red wire to a key controlled accessory circuit of the ATV (use the provided wire splice). Using a test light, locate a suitable wire from the ATV key switch. The wire should only have power when the key is in the "ON" position.

NOTE: If installing both switches, both red wires MUST be spliced to a key controlled accessory circuit of the ATV as described above.

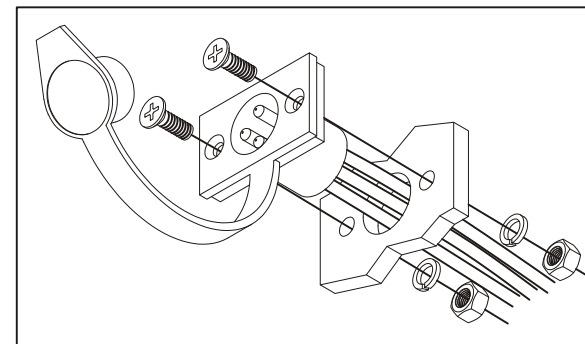

Figure 9. Remote socket installation.

Step 5 - Install the Wiring



Place the supplied terminal boots on wires before securing to the contactor. All wires must be attached to the contactor before mounting the contactor to the ATV.

- Connect one terminal (marked "M+") of contactor to terminal positive (+) of the motor with red cable.
- Connect one terminal (marked "M-") of contactor to terminal negative (-) of the motor with black cable.

- Connect one terminal (marked “B+”) of contactor to terminal positive (+) of the battery with red cable .
- Connect one terminal (marked “B-”) of contactor to terminal negative (-) of the battery with black cable.
- If installing both the handle bar switch and the remote socket, first attach the terminals on the green and black remote socket wires into the contactor (green to green, black to black), second connect the red cable of remote socket to the terminal (marked “B+”) of the contactor , or connect the red cable of remote socket to the key.

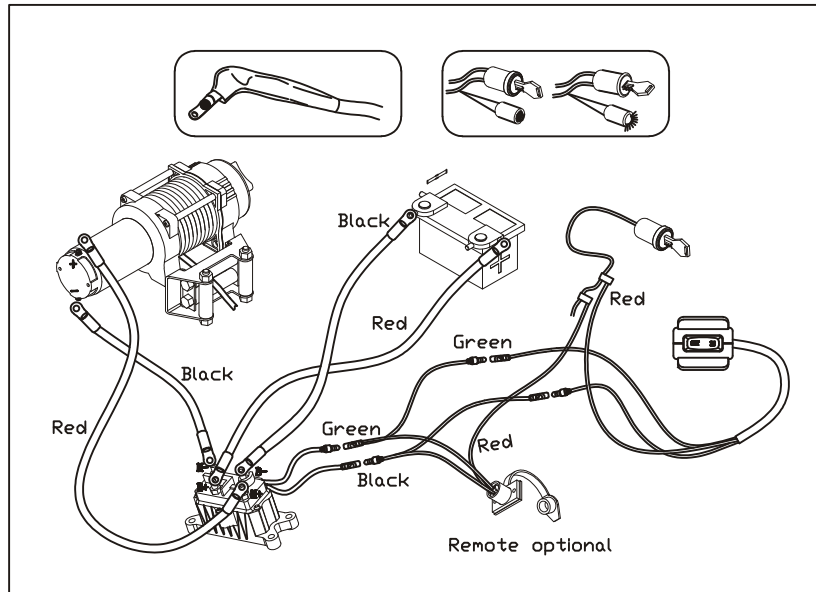

Figure 11. Wiring Installation diagram

- **Always** remove jewelry and wear eye protection.
- **Never** lean over battery while making connections.
- **Always** verify area is clear of fuel lines, fuel tank, brake lines, electrical wires, etc.

When drilling.

- **Never** route electrical cables:
 - Across any sharp edges.
 - Through or near moving parts.
 - Near parts that become hot.
- **Always** insulate and protect all exposed wiring and electrical terminals.
- **Always** install terminal boots as directed in installation instructions.

Step 6 - Check the System

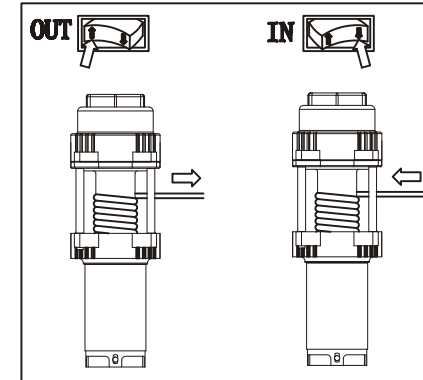

Before using the winch, verify the following:

- Wiring to all components is correct. All loose wires are tie wrapped tight.
- There are no exposed wiring or terminals. Cover any existing terminal exposures with terminal boots, heat shrink tubing or electricians tape.
- Turn ATV key switch to ON position. Check winch for proper operation. The wire rope should spool in and out in the direction indicated on the switch.

WINCH MAINTENANCE :

- No further internal lubrication is required for the life of the winch . The winch should not immersion in water (waterproof winch should not be soaked in water for a long time) . If the winch immersions in water by accident , you should loose the earth screw , put the net water as soon as possible . And you should use the winch within 3 days , make the motor to work and not stop until hands can feel it hot , as it can rid of water vapor into the motor .
- Lubricate the cable periodically, to replace a new cable as soon as possible if it glitch occurs, fracture, and creases.
- You should clean and lubricate after using; Also should store the winch in the dry and drain place, disengage the clutch , and avoid children to contact and play .
- Each assembly or connection screw is loosen, or corrosion , please repair and replace timely

Troubleshooting

NO.	SYMPTOM	POSSIBLE	SUGGESTED
1	Motor does not turn on	<ul style="list-style-type: none"> - Switch Assembly not connected properly - Loose battery cable Connections - Solenoid malfunctioning - Defective Switch Assembly - Defective motor - Water has entered motor 	<ul style="list-style-type: none"> - Insert Switch Assembly all the way into the connector. - Tighten nuts on all cable connections. - Tap solenoid to loosen contacts. Apply 12volts to coil terminals directly A clicking indicates proper activation. - Replace Switch Assembly - Check for voltage at armature port with Switch pressed. If voltage is present replace motor. - Allow to drain and dry. Run in short bursts without load until completely dry.
2	Motor runs but Cable drum does not turn	-Cam Ring (clutch) not engaged	-Move Cam Ring to the "in" position. If problem persists, a qualified technician needs to check and repair.
3	Motor runs slowly or without normal power	- Insufficient current or voltage	<ul style="list-style-type: none"> - Battery weak, recharge. Run winch with vehicle motor running. - Loose or corroded battery cable connections. Clean ,tighten, or replace
4	Motor runs too hot	- Long period of operation	-Let winch cool down periodically
5	Winch runs in one direction only	<ul style="list-style-type: none"> - Defective or stuck solenoid - Defective Switch Assembly 	<ul style="list-style-type: none"> - Tap solenoid to loosen contacts. - Repair or replace solenoid. - Replace Switch Assembly

Winch Assembly Drawing

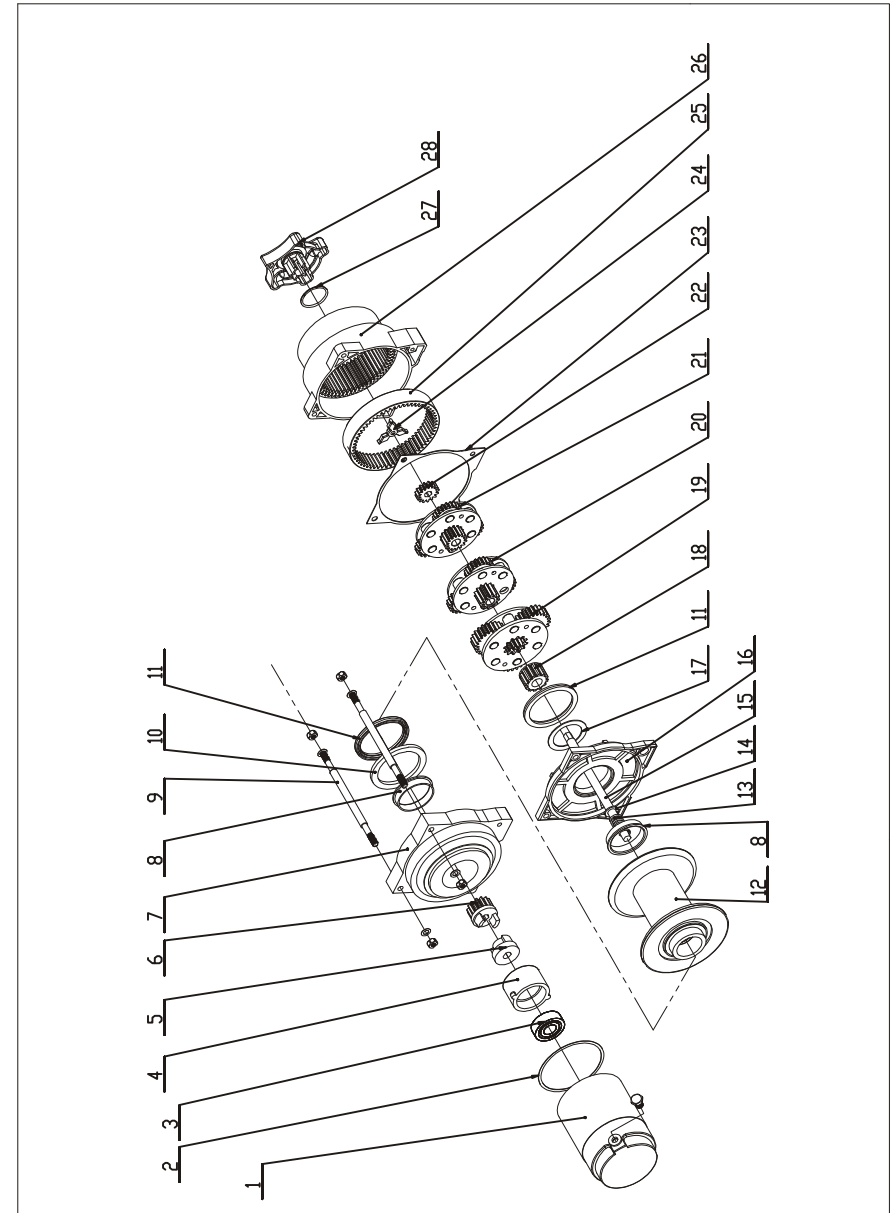



Winch Parts List

NO .	Part#	S.B part#	QTY	Description
1	300100	97203-01	1	Motor
2	300200	97203-02	1	gasket
3	300300	97203-03	1	bearing
4	300001	97203-04	1	bearing bushing
5	300002	97203-05	1	brake base
6	300003	97203-06	1	brake gear
7	300004	97203-07	1	drum support motorside
8	300400	97203-08	2	drum bushing
9	300005	97203-09	2	tie rod
10	300006	97203-10	1	bushing for waterproof
11	300007	97203-11	2	o-ring for waterproof
12	300008	97203-12	1	drum
13	300009	97203-13	1	spring
14	300010	97203-14	2	Split snap ring
15	300011	97203-15	1	shaft
16	300012	97203-16	1	gear box cover
17	300500	97203-17	1	Gasket
18	300013	97203-18	1	splined gear
19	300014	97203-19	1	Gear carrier assembly state 3
20	300015	97203-20	1	Gear carrier assembly state 2
21	300016	97203-21	1	Gear carrier assembly state 1
22	300017	97203-22	1	sun gear
23	300018	97203-23	1	gasket
24	300019	97203-24	1	Slide block for clutch
25	300020	97203-25	1	gear ring
26	300021	97203-26	1	gear box body
27	300022	97203-27	1	bushing
28	300023	97203-28	1	clutch knob
29	300022	97203-29	1	Wire rope and hook
30	300033	97203-30	1	Remote
31	300035	97203-31	1	Handle Bar Control
32	300036	97203-32	1	Winch Plate
33	300045	97203-33	1	Solenoid



XRC 3.0 (3,000lb) WINCH

Specifications

Rated line pull. 3000lbs (1360kgs) single line

Motor. Permanent magnetic DC 12V with 3.9hp/2.9kw output

Gear train. 3 stage planetary

Gear ratio. 136:1

Wire rope. 7/32" x 32'

Drum size. 50mm x 75mm

Dimensions. L x W x H (334mm x 114mm x 120mm)

N.W. 7.5 kg

G.W. 11 kg

Line Pull	lbs	0	1000	2000	3000
	kg	0	454	907	1361
Line Speed	ft/min	24.5	14.7	10.5	6.9
	m/min	7.5	4.5	3.2	2.1
Motor	Amps	15	75	120	175