

# TRAILFX

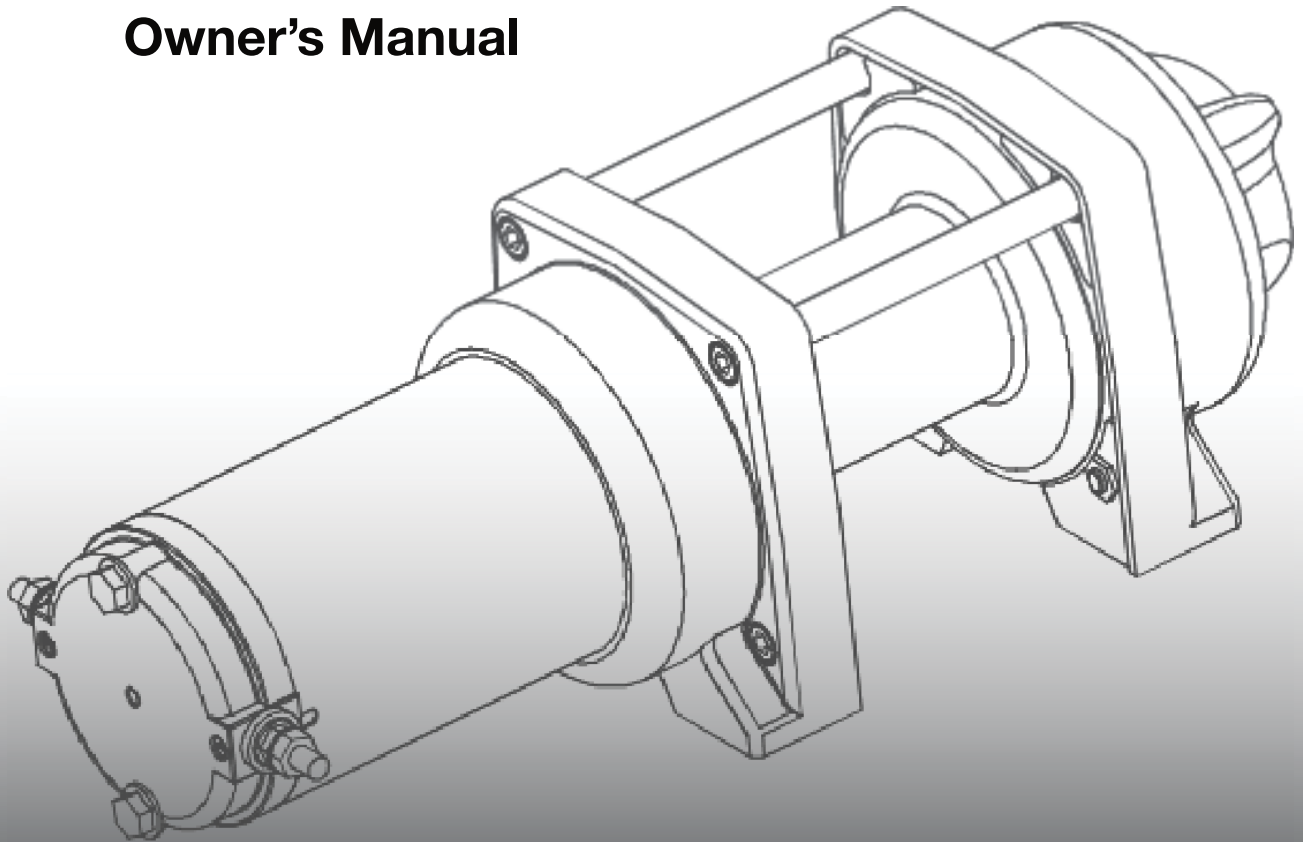

**ATV / UTV Winch**

**Owner's Manual**



# Key Winch Components

Part numbers : W35B and WS35B

## Motor Housing

Houses the series wound 12V DC motor which drives the gear system and ultimately driving the drum.

## Freespool Lever

Engages or Disengages the gear drive system allowing operator to pull the rated load or free spool the rope.

## Gear Housing

Houses maintenance free 3-stage planetary gear system that can be either 'Engaged' or 'Disengaged' by the operator.

## Fairlead

High quality fairlead for guiding the winch rope to and from the drum.

## Hook

Forged hook designed to safely handle rated winch load.

## Rope

High strength Wire / Synthetic rope designed to pull rated load safely. Always remain within the rated load per layer as specified in this manual and warning label. Always replace the rope with exactly the same type, length and rope strength as specified in this manual.

## Roller Fairlead ( Applicable for wire rope winch )

High quality roller fairlead for guiding the winch rope to and from the drum.

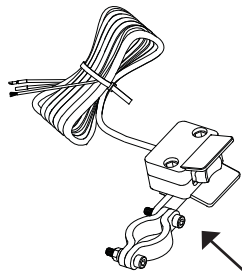

## Mini Rocker Switch

Allows the operator to control the winch direction from ATV handlebar itself.

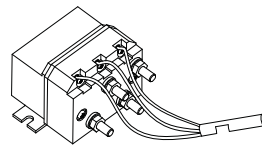

## Solenoid

Solenoid supplies power to the motor via mini rocker switch / remote control switch. Solenoid meets IP67 for water resistance.

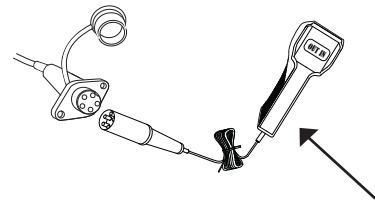

## Remote Control

Allows the operator to control the winch direction from a safe distance.

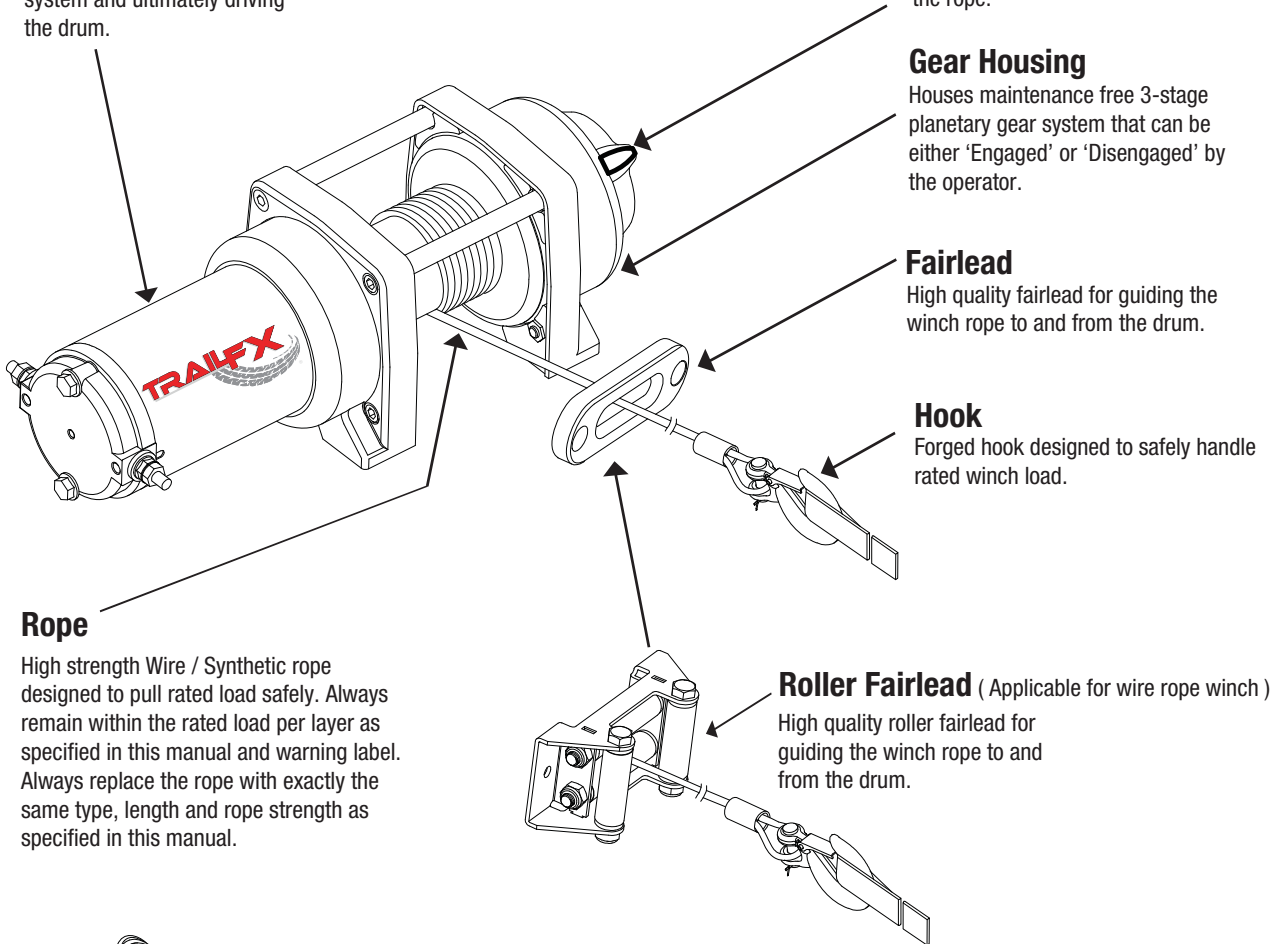

# Key Winch Components

Part numbers : W45B and WS45B

## Motor Housing

Houses the series wound 12V DC motor which drives the gear system and ultimately driving the drum.

## Freespool Lever

Engages or Disengages the gear drive system allowing operator to pull the rated load or free spool the rope.

## Gear Housing

Houses maintenance free 3-stage planetary gear system that can be either 'Engaged' or 'Disengaged' by the operator.

## Fairlead

High quality fairlead for guiding the winch rope to and from the drum.

## Hook

Forged hook designed to safely handle rated winch load.

## Rope

High strength Wire / Synthetic rope designed to pull rated load safely. Always remain within the rated load per layer as specified in this manual and warning label. Always replace the rope with exactly the same type, length and rope strength as specified in this manual.

## Roller Fairlead ( Applicable for wire rope winch )

High quality roller fairlead for guiding the winch rope to and from the drum.

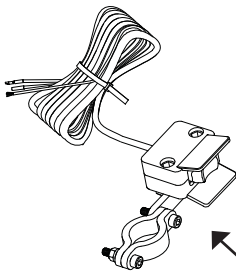

## Mini Rocker Switch

Allows the operator to control the winch direction from ATV handlebar itself.

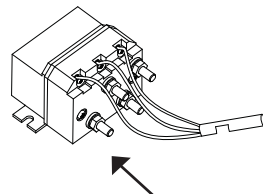

## Solenoid

Solenoid supplies power to the motor via mini rocker switch / remote control switch. Solenoid meets IP67 for water resistance.

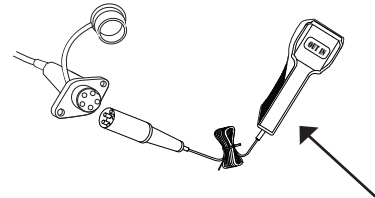

## Remote Control

Allows the operator to control the winch direction from a safe distance.

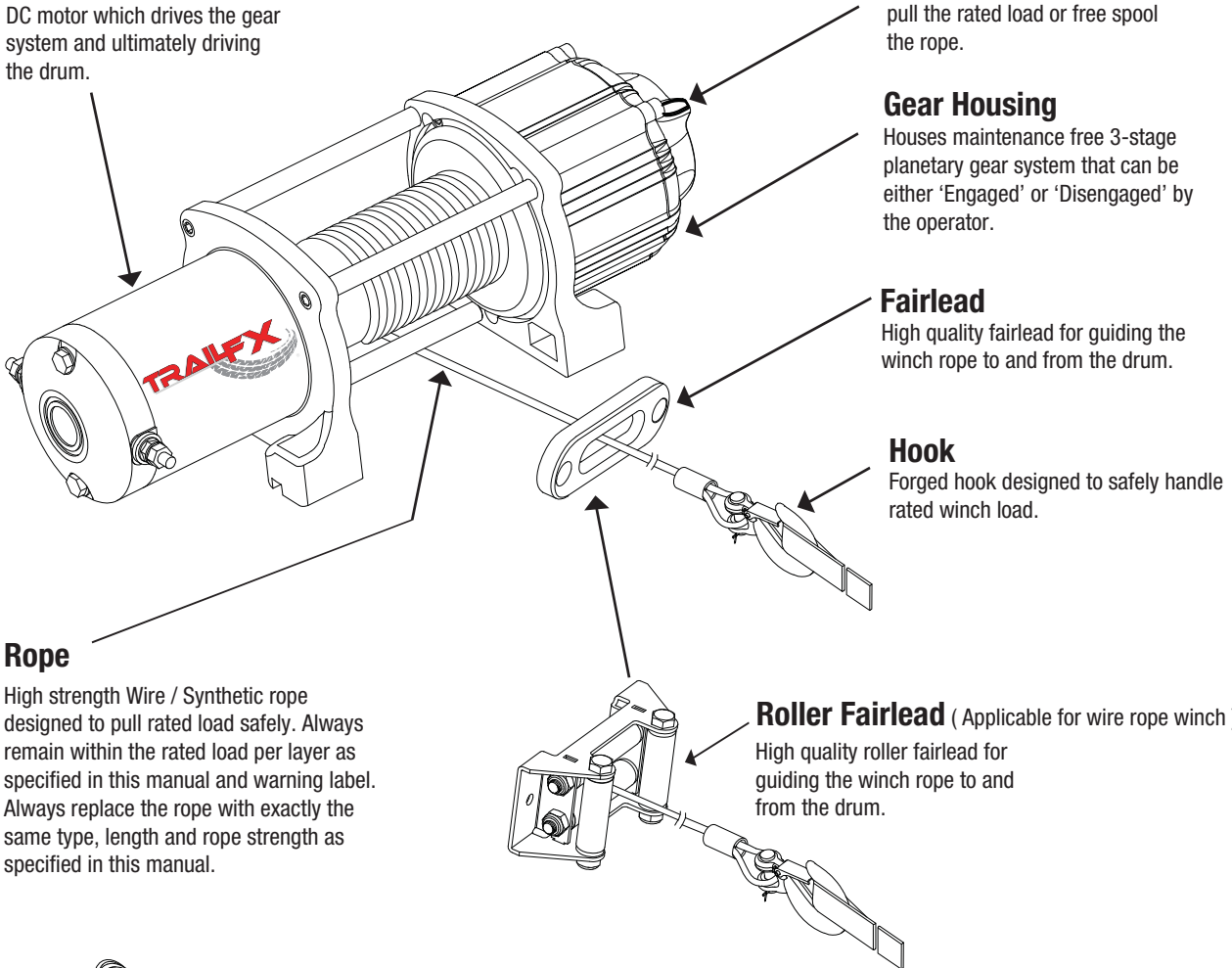

## Safety Precautions



**Observe safety precautions for personal safety and the safety of others.**

**Improper equipment operation may cause personal injury and equipment damage.**

**Never operate this winch if you are under 16 years of age.**

**Never operate this winch when under the influence of drugs, alcohol or medication.**

Read the following carefully before attempting to operate your winch and keep the instructions for future reference.

### 1. Dress Properly:

- Do not wear loose clothing or jewelry. They can be caught in moving parts.
- Wear proper winching gloves when handling the winch rope. Do not handle rope with bare hands as broken strands can cause injuries.
- Non-skid footwear is recommended.

### 2. Keep a Safe Distance:

- Ensure that all persons stand clear of winch rope and load during winch operation, 1.5 times of the length of the rope is recommended. If a rope pulls loose or breaks under load, it can lash back and cause serious injury or death.
- Do not step over the rope.
- All visitors and onlookers should be kept away from the work area.
- Keep proper footing and balance at all times.

### 3. Do Not Abuse Electrical Cables:

- Never carry your winch by the electrical cables or yank it to disconnect it from the receptacle.
- Keep electrical cables from heat, oil and sharp edges.

### 4. Do Not Overwork the Winch:

- If the motor becomes uncomfortably hot to touch, stop and let it cool for a few minutes.
- Shut off power to the winch if the motor stalls.



**Do not exceed maximum line pull ratings shown in tables.**

**Shock loads must not exceed these ratings.**

### 5. Avoid Unintentional Starting:

- Winch clutch should be disengaged when not in use and fully engaged when in use.

### 6. Check Damaged Parts:

- Before using, you should check your winch carefully. Any part that is damaged should be properly repaired or replaced. Technical support and replacement parts may be obtained by contacting customer service as specified on the back cover of the manual or on the warranty card.

### 7. Repair Your Winch:

- When repairing, use only identical replacement parts or it may cause considerable danger to the user. Replacement parts may be obtained from customer service as specified in page number 16.

### 8. Re-spool the Rope:

- Winching gloves must be worn while re-spooling. It is necessary to maintain a slight load on the rope. Hold the rope with one hand and the remote control switch with the other. Start as far back and in the center as you can. Walk up keeping load on the rope as the winch is powered in.
- Do not allow the rope to slip through your hand and do not approach the winch too closely.
- Turn off the winch and repeat the procedure until all the rope is spooled except 3 ft.
- Disconnect the remote control switch and finish spooling in rope by rotating the drum by hand with clutch disengaged.
- On hidden winches, spool in rope under power but keep hands clear.

## Winch Operation Warnings

Read the following carefully before attempting to operate your winch and keep the instructions for future reference.

1. The uneven spooling of rope, while pulling a load, is not a problem, unless there is rope stacked up on one end of the drum. If this happens, reverse the winch to relieve the load and move your anchor point further to the center of the vehicle. Once complete, you can unspool and rewind for a more balanced lay of the rope.
2. Store the remote control switch inside your vehicle where it will not get damaged. Inspect it before you plug in.
3. Turn ATV key switch to ON position. Check winch for proper operation. The rope should spool in and out in the direction indicated on the rocker switch / remote control.
4. When ready to begin spooling in, plug in remote control switch or use handle bar rocker switch with clutch disengaged. Do not engage clutch with motor running.
5. Never connect the hook back to the rope as this causes rope damage. Always use a sling or chain of suitable strength.
6. Observe your winch while winching if possible, standing at a safe distance. Stop the winching process every meter or so to assure the rope is not pulling in one corner. Jamming the rope can break your winch.
7. Ensure "D" rated, or bow shackles are used in conjunction with an approved tree trunk protector to provide a safe anchor point.
8. When extending the winch rope, ensure that at least five wraps of rope remain on the drum at all times. Failure to do this could result in the rope parting from the drum under load. Serious personal injury or property damage may result.
9. After winch use, always prepare your winch for storage. Inspect the installation, rope, rigging, and accessories for any damage that may have occurred during use. Inspect the winch by checking the tightness of mounting bolts and checking the winch for any loose components or fasteners.
10. The solenoid is a primary safety feature in your winch system. It disconnects your winch from the battery when the ATV is not in use. The solenoid must be correctly installed for the winch to work properly.



**11. All winches are provided with a red marking on the rope which identifies where (5) rope wraps remain on the winch drum. No recovery should be attempted beyond this marking or serious injury may occur.**

12. Since the maximum line pull is achieved on the first layer of the winch, it is desirable to pull off as much line as you can for heavy pulls. Doubling or tripling snatch blocks can help. You must leave at least five wraps minimum on the drum or see red rope NOT exposed!
13. Draping a heavy blanket or similar object over the extended winch rope is recommended as it will dampen any back lash should a failure occur.
14. Neat, tight spooling avoids rope binding, which is caused when a load is applied and the rope is pinched between the others. If this happens, alternatively power the winch in and out. Do not attempt to work a bound rope under load, free by hand.
15. Apply blocks to wheels when vehicles are on an incline.
16. Battery:
  - Be sure that the battery is in good condition. Avoid contact with battery acid or other contaminants.
  - Always wear eye protection when working around a battery.
  - Have the engine running when using the winch, to avoid rapid degradation of the battery.

## ATV Winch Kit Mounting:

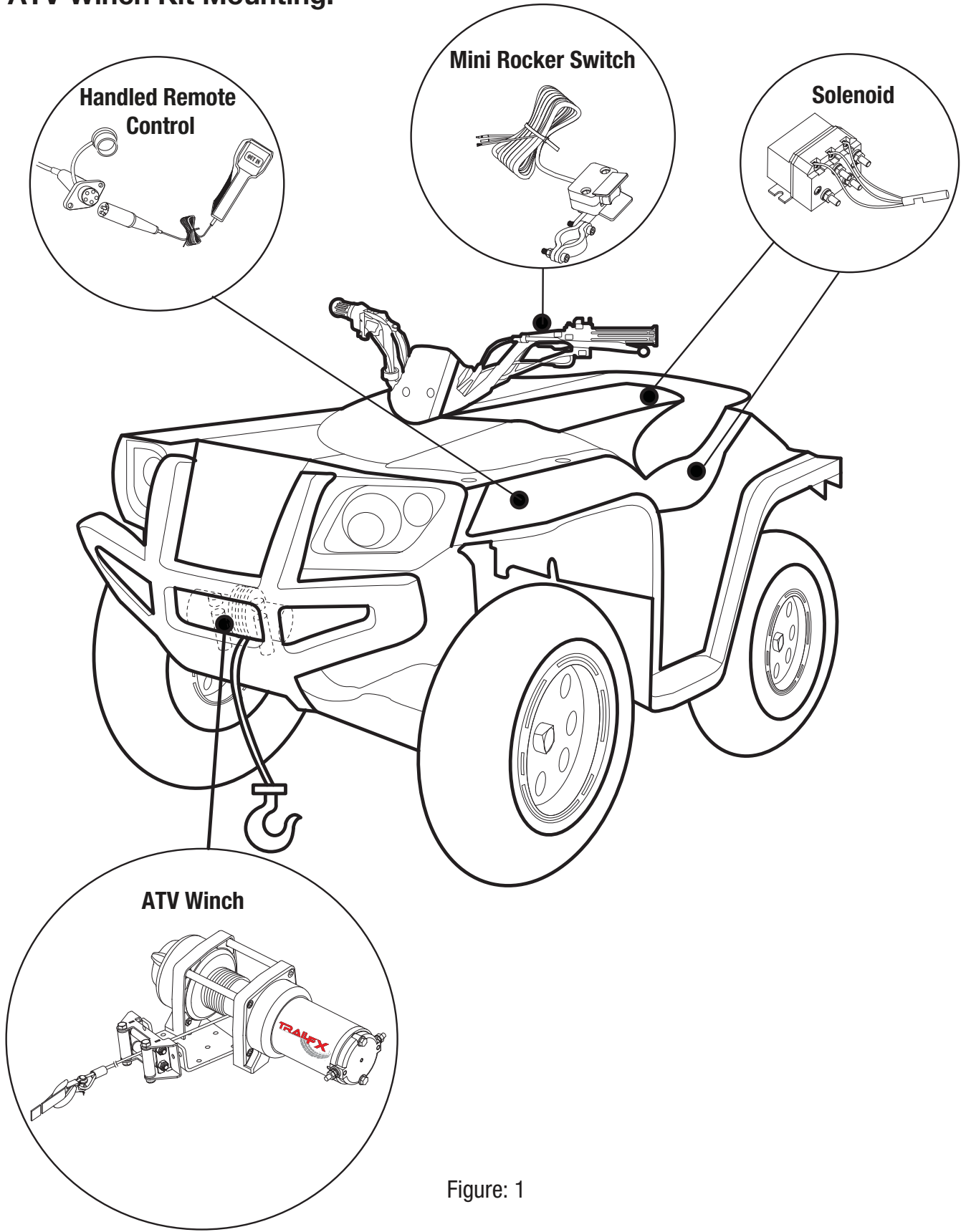
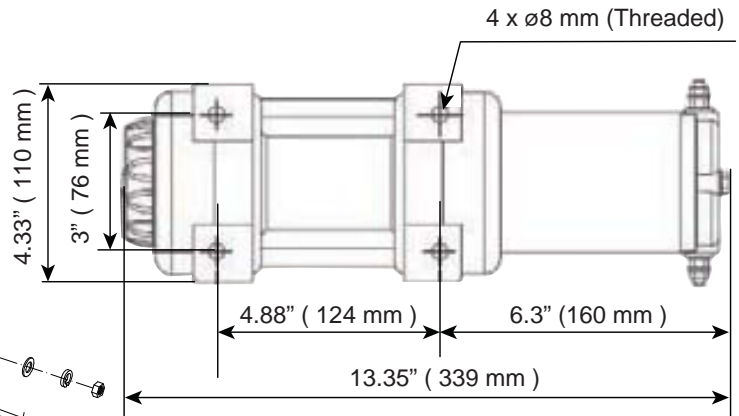
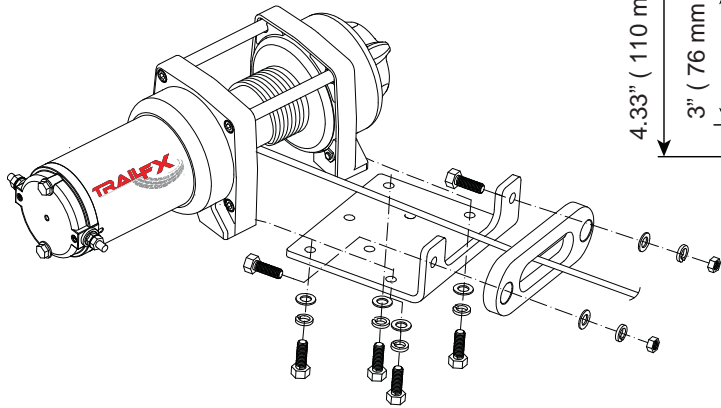

Figure: 1

To install an ATV winch, you need to mount the winch, solenoid, Handlebar Mini Rocker switch & Remote socket (female Receiver). Winch & Accessory mounting locations may vary depending on your ATV/UTV Make/Model. Please read the ATV Winch Kit mounting instructions provided on the next page.

## WINCH MOUNTING

### W35B, WS35B



### W45B, WS45B

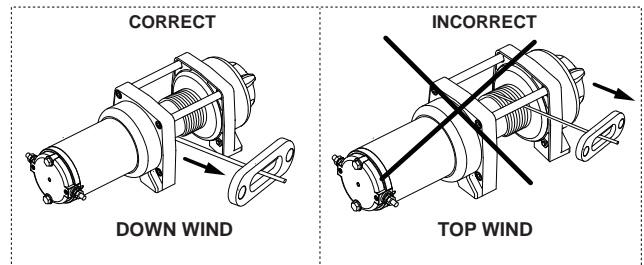
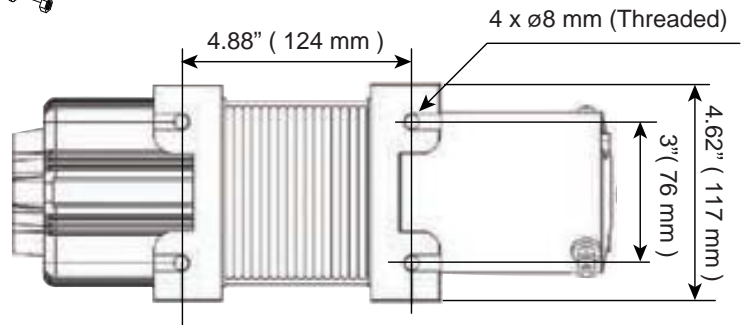
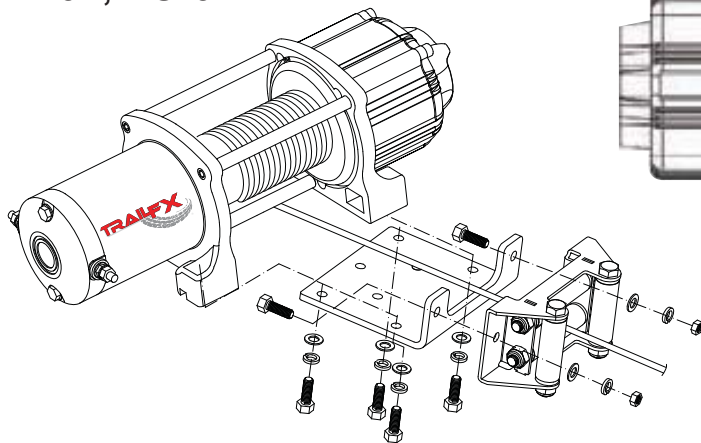

Figure: 2

## Solenoid Mounting

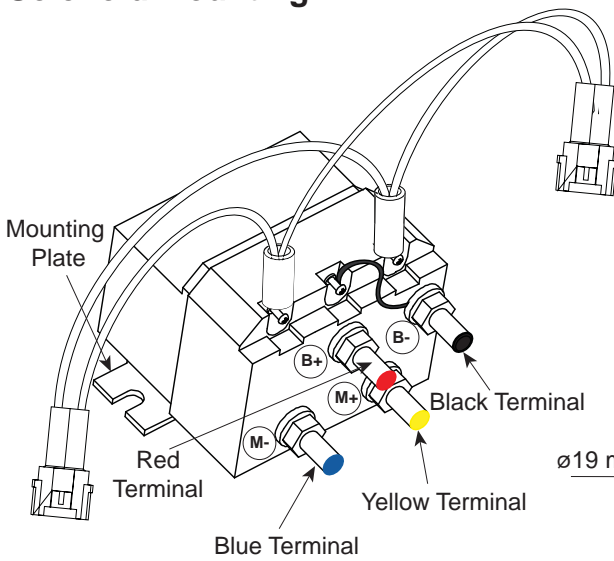

Figure: 3

## Handlebar Mini Rocker Switch

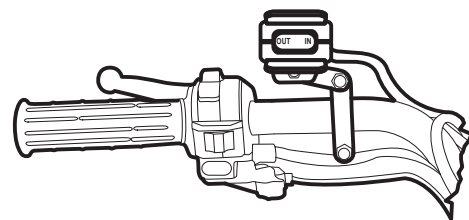

Figure: 4

## Handheld Remote Control

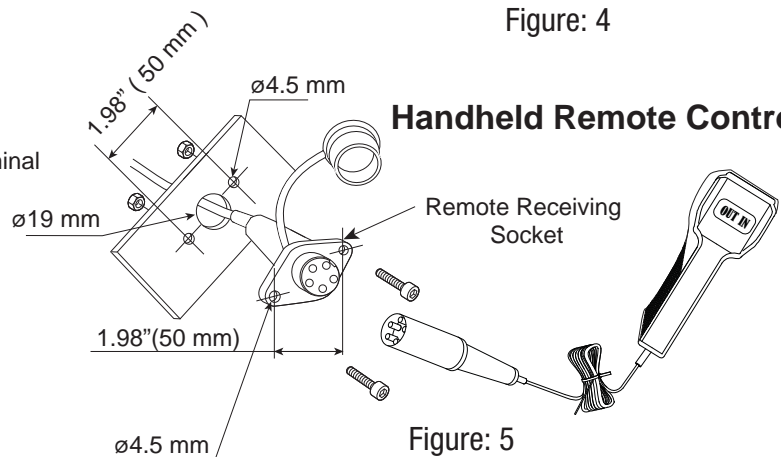

Figure: 5

## **Winch Mounting:**

1. To secure the winch, always use a flat, secure mounting location at least 3/16 inch (4.8 mm) thick.
2. 5/16-18 x 1 inch grade 5 hexagonal head cap screws and lock washer supplied with TrailFX ATV/UTV Winch kit.
3. Torque mounting bolts to 12 lbs/ft (1.7 kg-m).
4. Attach roller fairlead / aluminium fairlead to winch mounting plate using 3/8-16 bolts, nuts and washers
5. Attach the clevis Hook to the rope.
6. Put the clutch in freespool position & manually feed cable loop through fairlead.
7. Attach hook to cable loop and re-engage the clutch.
8. Refer to figure No. 2 for the mounting pattern & dimensions.
9. After mounting, rope should be in the under wind direction as shown in the figure 2. Over-winding the rope may damage the winch and void warranty.

## **Solenoid Mounting:**

1. The solenoid disconnects the winch from the power source (Battery) when ATV is not in use.
2. The solenoid should be mounted on a safe, clean place close enough to the battery.
3. The solenoid can be placed under the seats, in the rear storage box, or as recommended by the ATV manufacturer.
4. The solenoid should have enough clearance from other metal parts of the ATV to avoid direct contact, which may lead to solenoid malfunction.
5. Drill mounting holes for the solenoid, however do not mount the solenoid until you attach all the cables from the battery, handlebar mini rocker switch & remote control.
6. Cable colors should be matched with the contact terminal color codes (M+, M-, B+, B-) as shown in the figure 3.

## **Handlebar Mini Rocker Switch Mounting:**

1. Using the supplied black coated mounting clamp & screws, mount the mini rocker switch on the handlebar.
2. A small piece of electrical tape could be used to avoid rotation of mini rocker switch cable after mounting on the handlebar. (**NOTE:** It's recommended to mount this mini rocker switch on the left side of the handlebar).
3. After mounting the mini rocker switch, route the cables to the place where the solenoid is mounted. Connect the small red lead into the wire that electrifies with the ignition switch "ON" and not electrifies with the ignition switch "OFF" as shown in the figure No 6. The wire should only have power when the ATV/UTV key is in the "ON" position (Preferably fuse controlled).

## **Remote Control Socket Mounting:**

1. Select a place to mount the remote control socket (female receiver).
2. Drill 3 holes as per the pattern & dimensions shown in the figure 5 and mount the socket.
3. After mounting the remote socket, route the cables to the place where the solenoid is mounted. Connect the small red lead into the wire that electrifies with the ignition switch "ON" and not electrifies with the ignition switch "OFF" as shown in the figure No 6. The wire should only have power when the ATV/UTV key is in the "ON" position (Preferably fuse controlled).
4. Keep the remote socket closed with the built in cap when not in use.

## Electrical Connection:

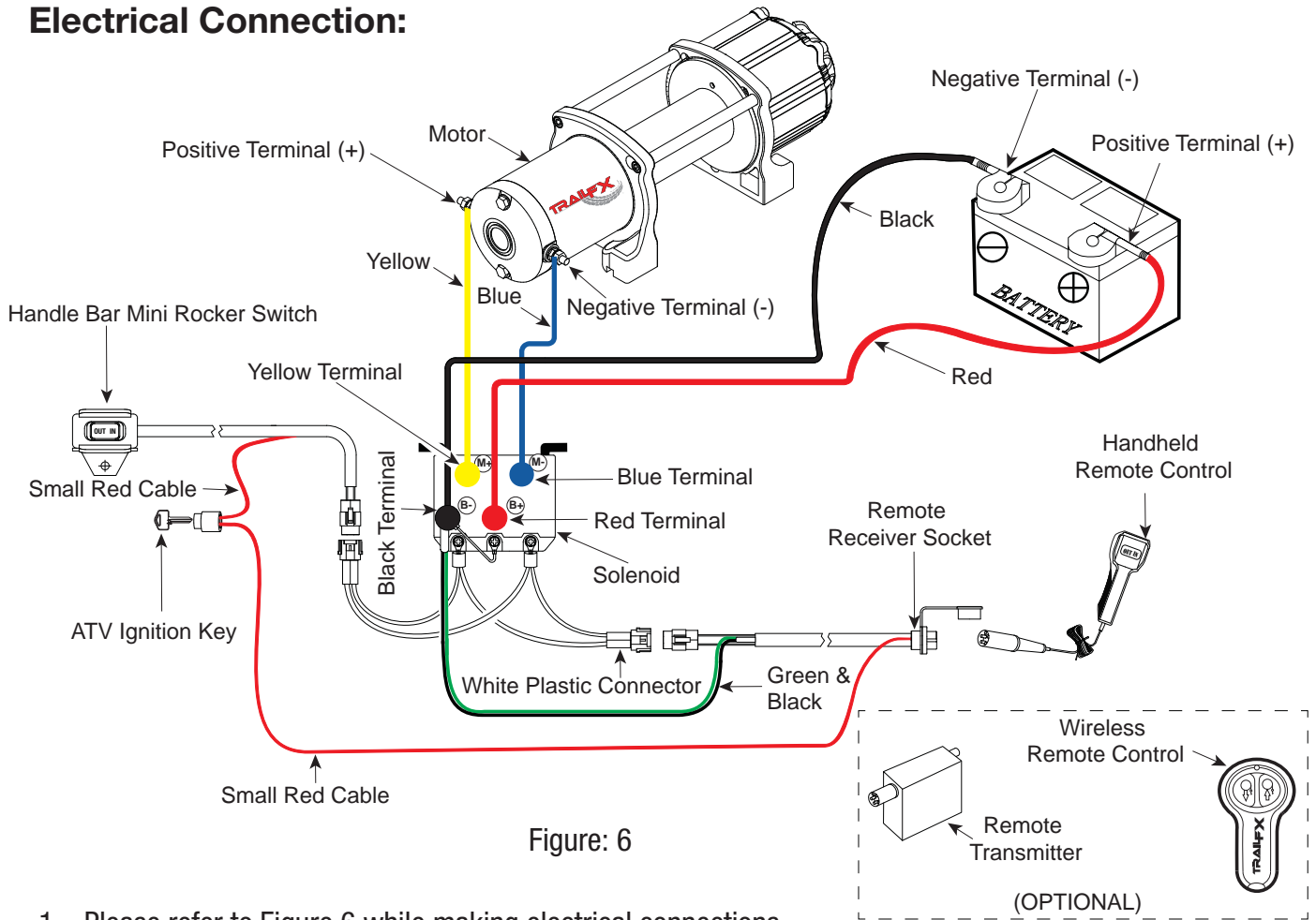

Figure: 6

1. Please refer to Figure 6 while making electrical connections.
2. Connect one end of the "Yellow" cable to the positive (+) Terminal of the winch motor.
3. Connect the other end of the "Yellow" cable to the "Yellow Terminal marked as M+" on the solenoid.
4. Connect one end of the "Blue" cable to the negative (-) Terminal of the winch motor.
5. Connect the other end of the "Blue" cable to the "Blue Terminal marked as M-" on the solenoid.
6. Connect one end of the "Red" cable to the "Red terminal marked as B+" on the solenoid.
7. Connect one end of the "Black" cable to the "Black terminal marked as B-" on the solenoid.
8. There are 2 white plastic connectors provided from the solenoid.
9. Connect any one of the white plastic connectors with the black jacketed cable which is connected to the handlebar mini rocker switch on the other end.
10. Connect the other white plastic connector with the black jacketed cable which is connected to the remote receiver socket on the other end.
11. Make sure that the 2 small red cables coming from the handlebar mini rocker switch & handheld remote control are connected to the ATV Ignition switch as stated under the handlebar mini rocker switch mounting Instructions & remote control mounting instructions on the previous page.
12. Connect the loose end of the "Red" cable from the red terminal of solenoid to the positive (+) terminal of the battery.
13. Connect the loose end of the "Black" cable from the black terminal of the solenoid to the negative (-) terminal of the battery.
14. Make sure that all the cable connections are properly connected with the referred terminals and are secured, clear of sharp edges & metal objects.
15. Use the provided black color cable / terminal protectors to protect connection points.
16. Use extra electrical insulation tape & cable tie wraps to secure wiring.

# Winch Operation

## Suggestion

The best way to get acquainted with how your winch operates is to make a few test runs before you actually need to use it. Plan your test in advance. Remember you can hear your winch as well as see it operate. Recognize the sound of a light steady pull, a heavy pull, and sounds caused by load jerking or shifting. Soon you will gain confidence in operating your winch and its use will become second nature to you.

## Operating

1. Ensure the vehicle is secure by applying the parking brake or chocking the wheels.
2. Pull out the rope to the desired length and connect to an anchor point. The winch clutch allows rapid uncoiling of the rope for hooking onto the load or anchor point. The shifter tab located on the gear housing of the winch operates the clutch as follows:
  - a) To disengage the clutch, rotate the clutch shifter tab into the “FREESPOOL” position. Rope may now be free spooled off the drum.
  - b) To engage the clutch, move the clutch shifter tab into the “ENGAGED” position. The winch is now ready for pulling.
3. Recheck all rope rigging before proceeding.
4. Plug in the winch remote control or use the handlebar mini rocker switch. It is recommended that the winching operation takes place from the driver’s position to ensure safe operation.
5. To commence winching operation, start vehicle engine, place transmission in neutral, maintain engine speed at idle.
6. Operate the handlebar mini rocker switch / remote control switch to IN or OUT until the vehicle has been retrieved. Regularly check the winch to ensure rope is winding onto the drum evenly.
7. TrailFX ATV/UTV Winches are designed for intermittent use only. DC powered motor installed on these winches can operate continuously under load for less than a minute and should be cooled down for several minutes before operating again.
8. Longer runs will make the motor load heavier, causing the motor to create excessive heat, lower speed and increase risk of potential winch failure. If the motor becomes uncomfortably hot to touch, stop and let it cool for a few minutes, before winching again.



## MUST READ



1. Never winch with your vehicle in gear. This could damage your vehicle’s transmission.
2. Never wrap the rope around the object and hook onto the rope itself. This can cause damage to the object being pulled, and kink or fray the rope.
3. Keep hands, clothing, hair and jewelry clear of the drum area and rope when winching.
4. Never use the winch if the rope is frayed, kinked or damaged.
5. Never allow anyone to stand near the rope or in line with the rope behind the winch while it is under power. If the rope should slip or break, it can suddenly whip back towards the winch, causing a hazard for anyone in the area. Always stand safely to the side while winding.
6. Do not leave the remote control plugged in when not in use.



**EVEN UNDER NO LOAD CONDITION, NEVER OPERATE WINCH FOR MORE THAN 2 TO 3 MINUTES CONTINUOUSLY! LONG DURATION PULLS MAY CREATE EXCESSIVE HEAT ON THE MOTOR, CAUSING WINCH FAILURE & VOID WARRANTY!**

## Maintenance

It is highly recommended that the winch be used regularly (once a month). Simply power the rope out 24 ft., free spool 9 ft. and then power back in. This will keep all components in good working condition so that the winch can be relied on when needed. Contact your dealer for technical assistance and repairs.

Trouble Shooting		
Symptom	Possible Cause	Suggested Remedy
Motor does not turn on	Switch assembly not connected properly.	Insert switch assembly firmly to the connector.
	Loose battery cable.	Tighten nuts on cable connectors.
	Solenoid malfunctioning.	Tap solenoid to free contact, applying 12 volts to coil terminal directly. Make an audible clicking when activating.
	Defective rocker switch assembly.	Replace rocker switch assembly.
	Defective motor.	Check for voltage at armature port with switch pressed. If voltage is present, replace motor.
	Water has entered motor.	Drain and dry, run in short bursts without load until completely dry.
Motor runs too hot.	Long period of operation.	Let winch cool down periodically.
Motor runs slowly or without normal power.	Battery runs down.	Recharge battery by running vehicle.
	Insufficient current or voltage.	Clean, tighten or replace the connector.
Motor runs but rope drum does not turn.	Clutch not engaged.	Turn clutch into engaged position, if that does not work, ask a qualified technician to check and repair
Motor runs in one direction only.	Defective or stuck solenoid.	Tap solenoid to free contacts. Repair or replace solenoid.
	Defective rocker switch assembly.	Replace rocker switch assembly.

## Lubrication

All moving parts in the winch are permanently lubricated with high temperature lithium grease at the time of assembly. Lubricate wire rope periodically using light penetrating oil. Inspect for broken strands and replace if necessary. If the rope becomes worn or damaged it must be replaced.

## Rope Installation

Unwind the new rope by rolling it along the ground, to prevent kinking. Remove the old rope and observe the manner in which it is attached to the rope drum flange. Install the new rope in the same way as the old rope is attached to the rope drum flange.



**Replace rope with the same type, exact diameter, length and strength as that of the existing rope. Use of different type rope will void warranty!**

<b>TrailFX ATV / UTV Winch Specifications</b>				
TrailFX Part No.	<b>W35B - Steel Rope</b>	<b>WS35B - Synthetic Rope</b>	<b>W45B - Steel Rope</b>	<b>WS45B - Synthetic Rope</b>
Rated Line Pull	3500lbs (1581kgs) single-line	3500lbs (1581kgs) single-line	4500lbs (2045kgs) single-line	4500lbs (2045kgs) single-line
Motor	3.8 HP Permanent magnet motor	3.8 HP Permanent magnet motor	4.5 HP Permanent magnet motor	4.5 HP Permanent magnet motor
Remote Control	Mini rocker switch & handheld remote control	Mini rocker switch & handheld remote control	Mini rocker switch & handheld remote control	Mini rocker switch & handheld remote control
Electrical Control	250A Solenoid	250A Solenoid	250A Solenoid	250A Solenoid
Gear Train	3 Stage planetary	3 Stage planetary	3 Stage planetary	3 Stage planetary
Gear Ratio	136 : 1	136 : 1	166 : 1	166 : 1
Clutch Type	Cam activated	Cam activated	Cam activated	Cam activated
Braking Action	Mechanical brake	Mechanical brake	Mechanical brake	Mechanical brake
Drum Size (Diameter X Length)	2.0" X 2.9"	2.0" X 2.9"	2.0" X 2.9"	2.0" X 2.9"
Rope (Diameter X Length)	3/16" X 50' Steel rope	3/16" X 50' Synthetic rope (Dyneema SK75 fibre)	13/64" X 40' Steel rope	15/64" X 40' Synthetic rope (Dyneema SK75 fibre)
Fairlead	4 Way roller fairlead	Aluminum fairlead	4 Way roller fairlead	Aluminum fairlead
Recommended Battery	650 CCA Minimum for winching	650 CCA Minimum for winching	650 CCA Minimum for winching	650 CCA Minimum for winching
Battery Lead	3/8" Sq. X 6'	3/8" Sq. X 6'	3/8" Sq. X 6'	3/8" Sq. X 6'
Weight	24 lbs	21 lbs	30 lbs	26.5 lbs
Mounting Pattern	3" X 4.88" (Universal type)	3" X 4.88" (Universal type)	3" X 4.88" (Universal type)	3" X 4.88" (Universal type)

<b>Winch Performance (12V DC)</b>								
<i>Performance specs are based on first layer of drum.</i>								
Line Pull (lbs)	Line Speed Ft / min	Motor Current Amps	Line Speed Ft / min	Motor Current Amps	Line Speed Ft / min	Motor Current Amps	Line Speed Ft / min	Motor Current Amps
0	21	19	21	19	17	20	17	20
1000	15	79	15	79	13	71	13	71
2000	11	138	11	138	10	124	10	124
3000					7	170	7	170
3500	7	225	7	225				
4500					5	227	5	227

Line Pull (Layer)	Line Pull by Layer (lbs)	Rope Capacity (Ft)	Line Pull by Layer (lbs)	Rope Capacity (Ft)	Line Pull by Layer (lbs)	Rope Capacity (Ft)	Line Pull by Layer (lbs)	Rope Capacity (Ft)
1	3500	8.85	3500	8.85	4500	7.5	4500	7.5
2	2561	19.22	2561	19.22	3673	16.3	3673	16.3
3	2234	31.11	2234	31.11	3102	26.8	3102	26.8
4	1981	44.52	1981	44.52	2685	40	2685	40

Motor rating based on input power.

Solenoid meets IP67 specification for water resistance.

# Parts List W35B and WS35B

3500lb

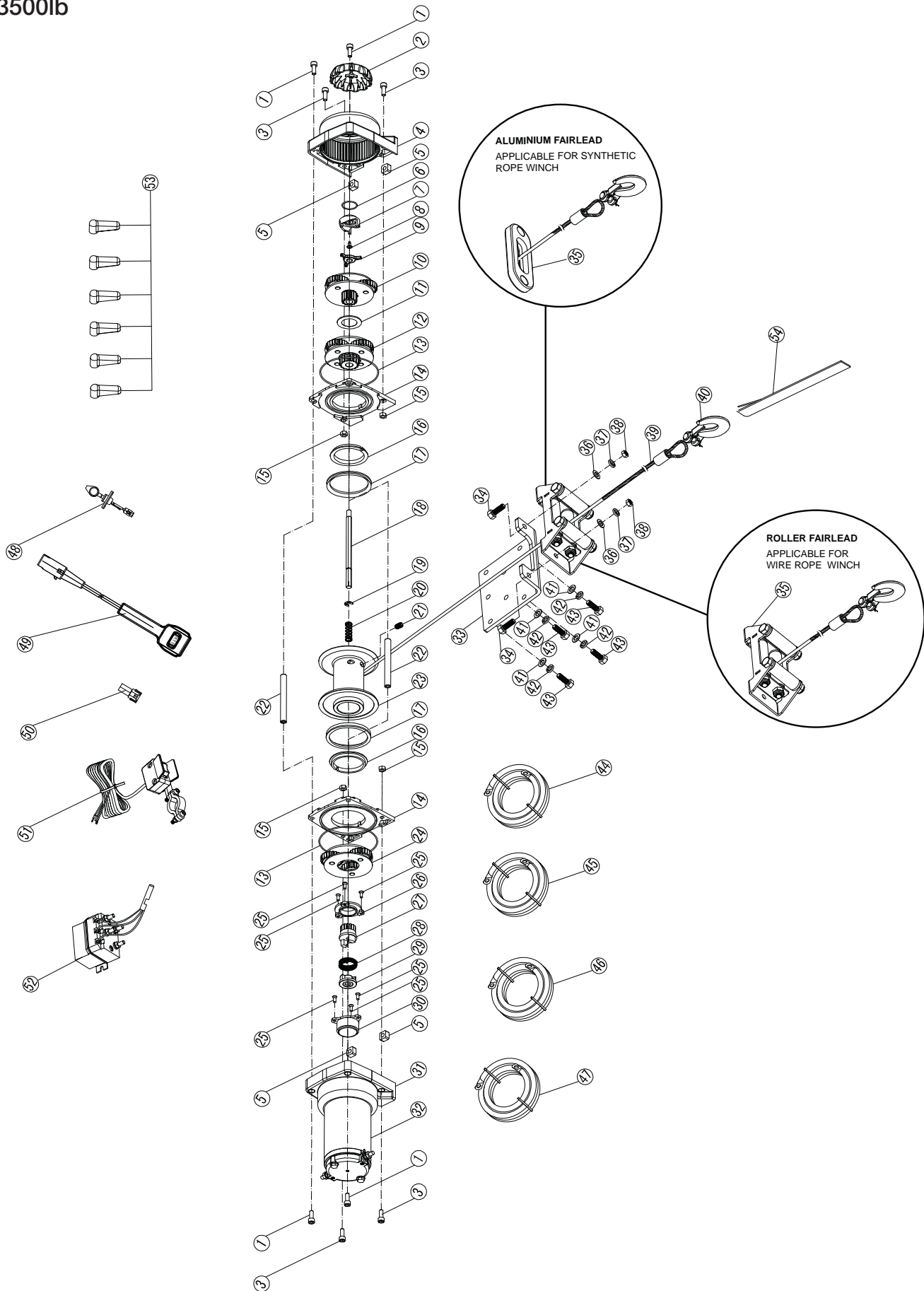

# Parts List W45B and WS45B

4500lb

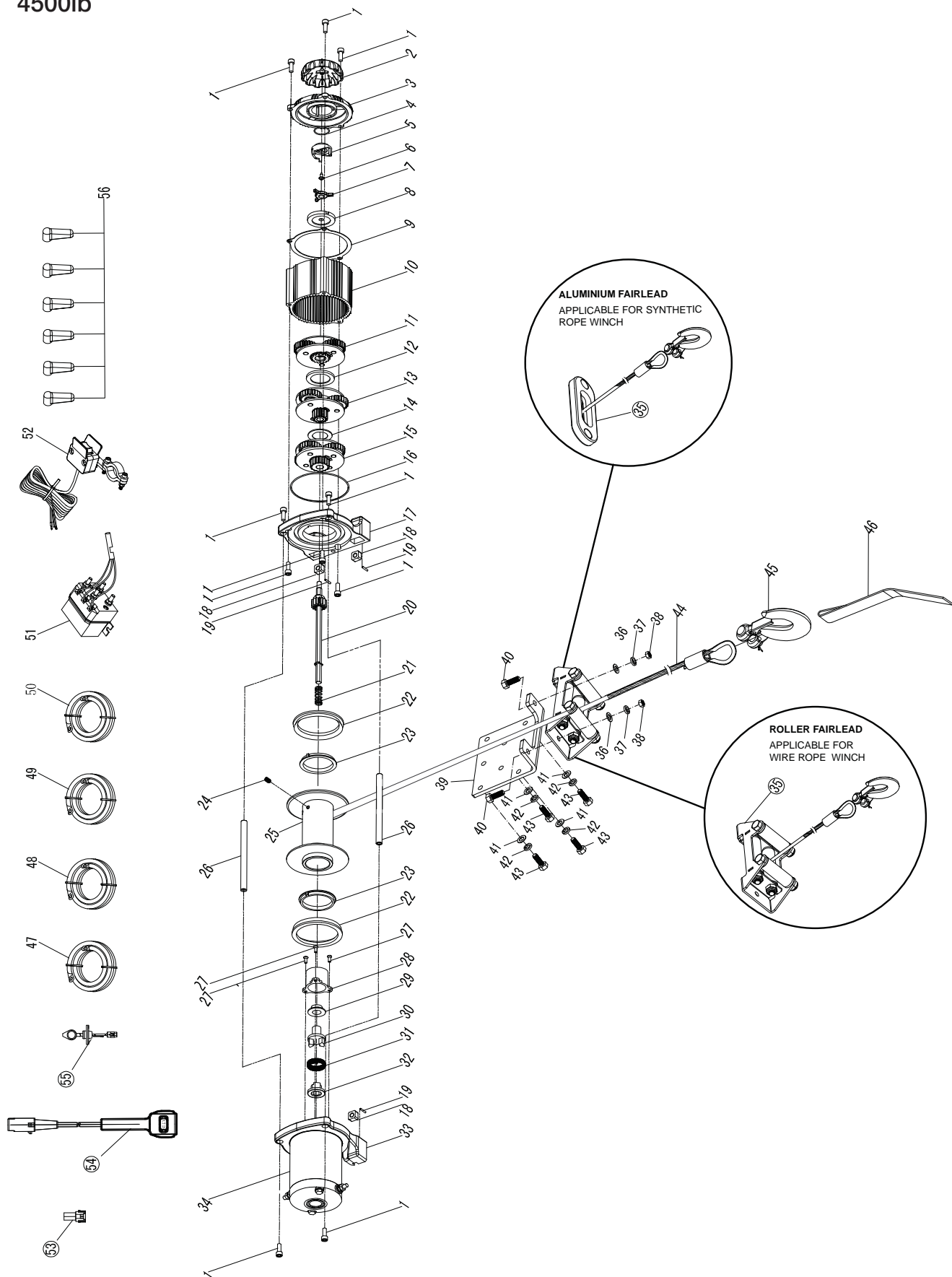

## Parts List W35B and WS35B

No.	Description	Qty
1	Socket head screw	4
2	Clutch knob	1
3	Socket head screw	4
4	Gear box	1
5	Nut	4
6	O Ring	1
7	Clutch knob base	1
8	Screw	1
9	Fork pin	1
10	2nd stage planetary gear	1
11	Spacer	1
12	3rd stage planetary gear	1
13	O Ring	2
14	Gear box cap	2
15	Nut	4
16	Nylon bearing	2
17	Seal	2
18	Drive shaft	1
19	Clip	1
20	Spring	1
21	Screw	1
22	Tie bar	2
23	Drum	1
24	1st stage planetary gear	1
25	Screw	6
26	Locating ring	1
27	Brake caliper	1
28	Spring	1
29	Brake base	1
30	Brake house	1
31	Gearbox (motor side)	1
32	Motor Assy	1
33	Mounting plate	1
34	Bolt	2
35	Fairlead - ( Applicable for synth rope )	1
35	Roller fairlead - ( Applicable for wire rope )	1
36	Washer	2
37	Lock washer	2
38	Nut	2
39	Wire rope	1
40	Hook 1/4	1
41	Washer	4
42	Lock washer	4
43	Bolt	4
44	Power lead red	1
45	Power lead black	1
46	Power lead blue	1
47	Power lead yellow	1
48	Connector Assy	1
49	Control handle	1
50	Plug-in components	1
51	Mini rocker switch	6
52	Solenoid	1
53	Brush	6
54	Hand strap	1

## Parts List W45B and WS45B

No.	Description	Qty
1	Socket head screw	10
2	Clutch knob	1
3	Cover of gear box	1
4	O Ring	1
5	Clutch knob base	1
6	Screw	1
7	Fork pin	1
8	Inner supporter	1
9	Gasket ring	1
10	Ring gear	1
11	1st stage planetary gear	1
12	Bulkhead	1
13	2nd stage planetary gear	1
14	Bulkhead	1
15	3rd stage planetary gear	1
16	O Ring	1
17	Gear box base	1
18	Nut	1
19	Elastic pin	4
20	Shaft Assy	4
21	Spring	1
22	Gasket ring	2
23	Nylon bearing	2
24	Screw	1
25	Drum	1
26	Tie bar	2
27	Screw	3
28	Brake house	1
29	Brake caliper	1
30	Locating ring	1
31	Spring	1
32	Brake base	1
33	Gear box (motor side)	1
34	Motor Assy	1
35	Fairlead - (Applicable for synth rope)	1
35	Roller Fairlead-(Applicable for wire rope)	1
36	Washer	2
37	Lock washer	2
38	Nut	2
39	Mounting plate	1
40	Bolt	2
41	Washer	4
42	Lock washer	4
43	Nut	4
44	Nylon rope	1
45	Hook 1/4	1
46	Hand Strap	1
47	Power lead red	1
48	Power lead black	1
49	Power lead blue	1
50	Power lead yellow	1
51	Solenoid	1
52	Mini rocker switch	1
53	Plug-in components	1
54	Control handle	1
55	Connector Assy	1
56	Brush	6

### Replacement Parts list

Part No.	Description	W35B	WS35B	W45B	WS45B
WA025	Remote control	☆	☆	☆	☆
WA026	Solenoid	☆	☆	☆	☆
WA027	Handlebar rocker switch	☆	☆	☆	☆
WA028	Synthetic rope		☆		
WA029	Synthetic rope				☆
WA030	Wire rope	☆			
WA031	Wire rope			☆	

☆ - Applicable

Part No.	Description	W35B	WS35B	W45B	WS45B
WA032	Roller fairlead	☆		☆	
WA033	Aluminum hawse, black		☆		☆
WA034	Cables set	☆	☆	☆	☆
WA035	Mounting plate	☆	☆	☆	☆
WA036	Forged hook	☆	☆	☆	☆
WA037	Mounting hardware set	☆	☆	☆	☆
WA038	Motor	☆	☆		
WA039	Motor			☆	☆