

Polaris Sportsman 550 & 850 Winch Mount MA11604

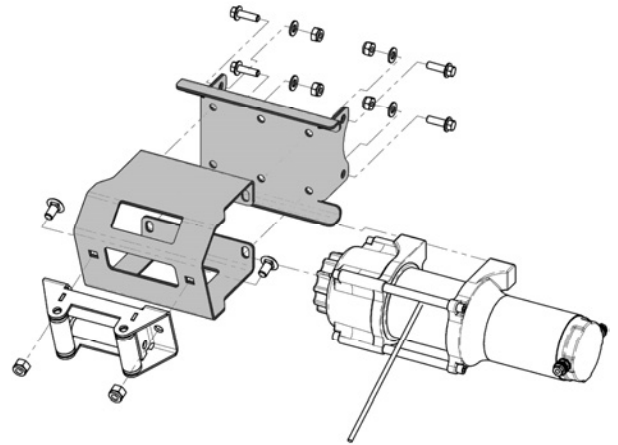

Kit Components:

<u>Qty</u>	<u>Part Description</u>
1.....	Winch Mount mounting channel
1.....	Winch Mount fairlead bracket
4.....	5/16-18 x 1 Hex Head Bolts
4.....	5/16-18 Nylock Nut
4.....	5/16 Flat Washer
1.....	6mm x 18mm Battery Bolt
1.....	Male Terminal (Fastenal: 0705161)
2.....	3/8" x 3/4" Carriage bolt
2.....	3/8" Locking Hex Nuts



INSTALLATION INSTRUCTIONS:

- Assemble the Hawse or Roller Fairlead (not included) to the fairlead bracket as shown using the supplied hardware (see Figure 1).
- Assemble your winch (not included) to the fairlead bracket and mounting channel as shown using the hardware supplied with your winch kit as shown in Figure 1. Don't forget to route your cable through your fairlead and attach your hook.
(NOTE: only 2 bolts will be used on the 2-hole mounted winches)
- Remove the two bolts shown in Figure 2 and remove the plastic bezel. Loosen the 2 bolts as shown in Figure 3 and rotate the metal cover downwards to allow for room to install the winch assembly. If preferred, you can remove the metal bezel in Figure 3 by removing the hardware.

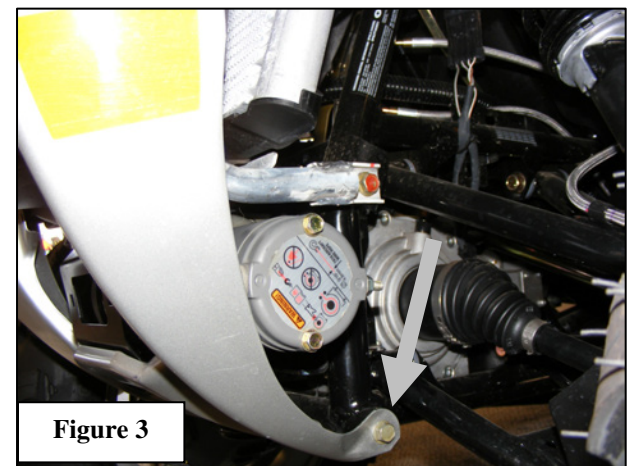
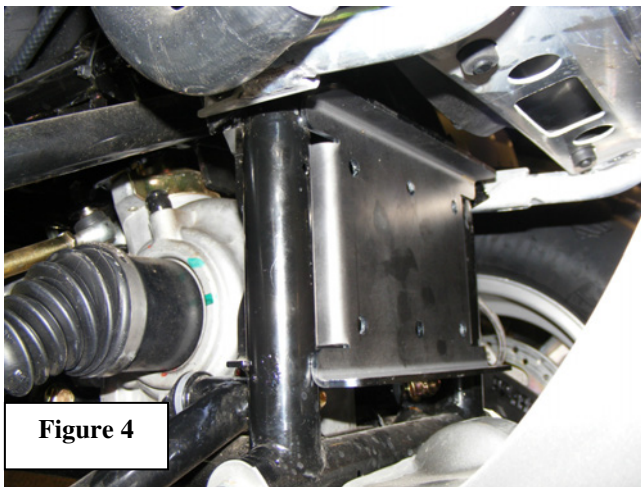
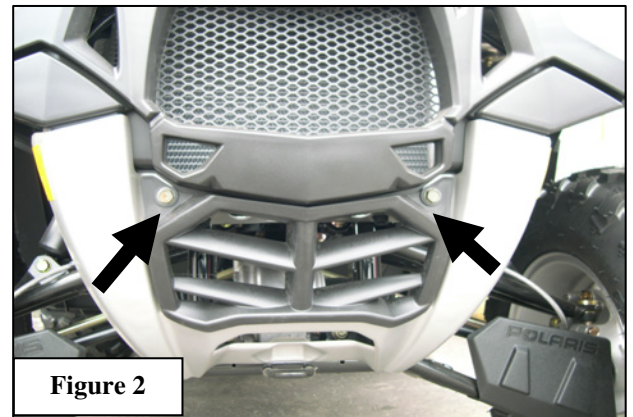

- Mount the entire winch assembly (winch, mount, and fairlead) into location as shown in Figure 4 and assemble using the included 5/16" hardware. The winch assembly should be pushed back and up before tightening the 5/16" bolts. *(NOTE: Figure 4 is only showing the mount bracket for clarification.)*

Polaris Sportsman 550 & 850 Winch Mount MA11604



5. Remove your front rack by releasing Polaris's Quick attaches and locate the winch wires located under the rack as shown in Figure 5.
6. Cut the zip ties that hold the wires in place and route the wires to the location of the winch leads. Remove the Red protective coverings from the wire ends and connect the cable to the appropriate lead on the winch (please refer to your winch's wiring diagram).
7. Remove the seat from your ATV and locate the Blue and Yellow wires in or near the battery Compartment as shown in Figure 6.
8. Locate the two holes shown in Figure 6. This is the mounting location for your Contactor. Mount your winch contactor (included with your winch kit) to this location, using the hardware included with your winch kit. *(NOTE: it is recommended to mount the contactor so that the switch wires are towards the middle of the ATV)*
9. Route the Blue and Yellow wires to the contactor and connect them to the correct locations. (please refer to your winch's wiring diagram)
10. Use the shorter wires (usually Red and Black) from your winch package and connect the contactor to your battery. (please refer to your winch's wiring diagram)
11. Remove the Front Bulkhead Access Cover, located just below the headlight pod as shown in Figure 5.
12. Route the switch wires (not included) from the selected switch location, through the steering post hole, and to the bulkhead (just below the headlight pod). Secure the switch in a desired location.
13. Locate the main wire harness just below the headlight pod. Find the orange/white wire connector and connect the switch accessory wire (if available with your winch kit, usually the Red wire coming out of your switch wiring) from the winch's switch to the orange/white wire using the supplied connector.

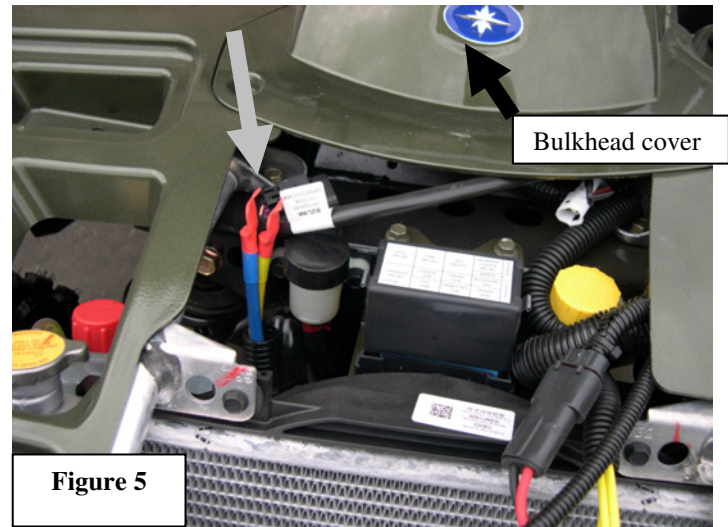

Figure 5

14. Continue Routing the switch wires to the contactor location as shown in Figure 6 and connect them to the contactor

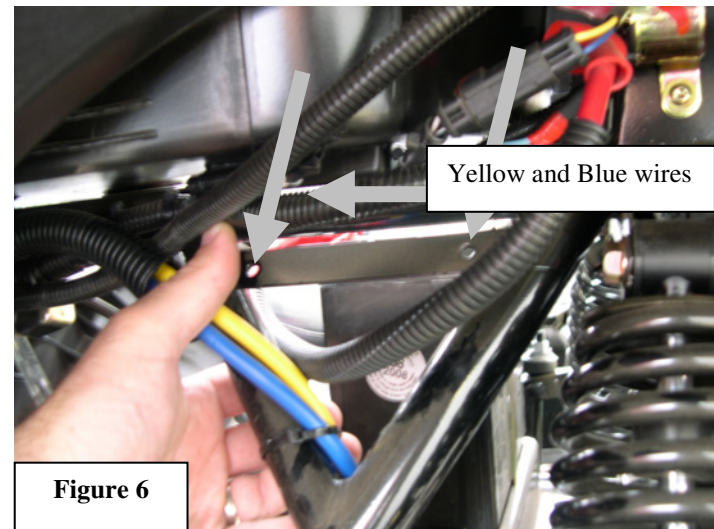

Figure 6

15. Reinstall and tighten all removed and loosened hardware and parts from the previous steps.
16. Test the winch for operation.

