

Teryx Winch Mount

MA11933

Kit Components

Qty	Part Description
1.....	Winch Mount
1.....	Reversible Fairlead Bracket
4.....	3/8" x 1.00" Carriage SN Bolt
2.....	3/8" x 1.00" Hex Head Bolt
6.....	3/8" Nylock Nuts
6.....	3/8" SAE Flat Washers

INSTALLATION INSTRUCTIONS:

1. Remove the front plastic bumper cover, by removing the (4) screws as shown in *Figure 1*.
2. Remove the front bumper, by removing the (4) bolts as shown in *Figure 2*.
3. Assemble your winch to the winch mount using the appropriate hole pattern and the hardware that was supplied with your winch as shown in *Figure 3&4*.
4. Assemble your fairlead to the fairlead bracket using the appropriate hole pattern and the hardware that was supplied with your winch as shown in *Figure 3&4*.

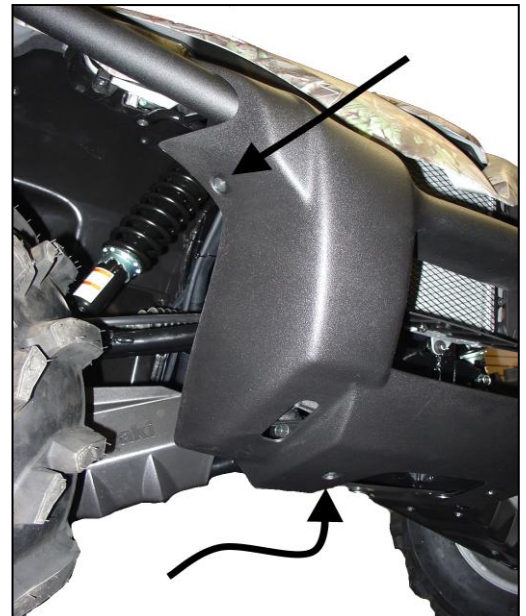

"Figure 1"
Remove Front Plastic Bumper Cover

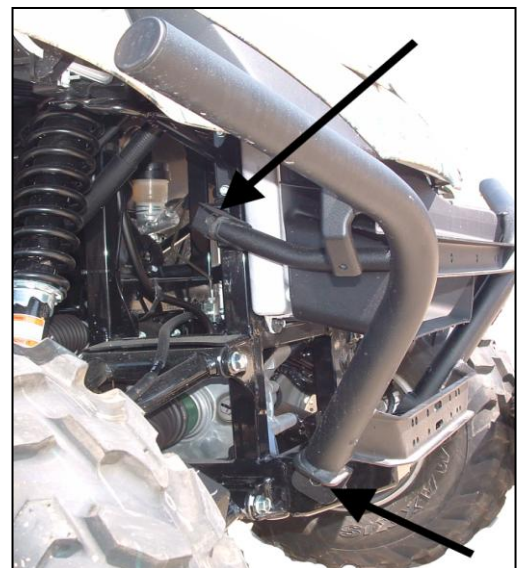

"Figure 2"
Remove the Front Bumper

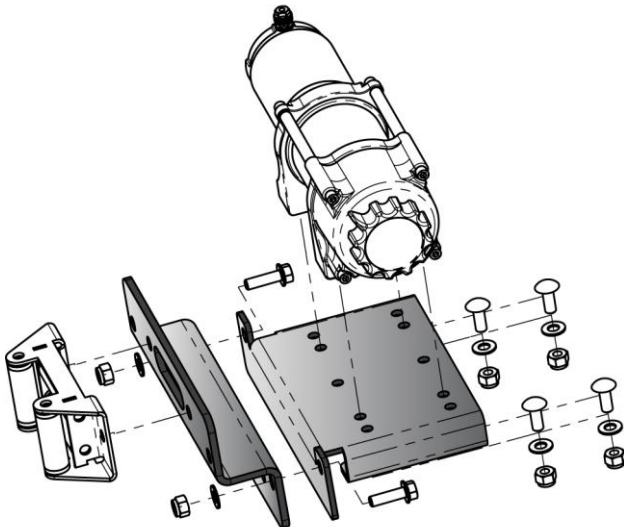

"Figure 3" 4.875" Standard Bolt pattern Set-up

NOTE: The fairlead bracket is reversible to accommodate the standard 4.875" bolt pattern fairleads and the larger 6.60" bolt pattern fairlead bracket found on wide spool winches.

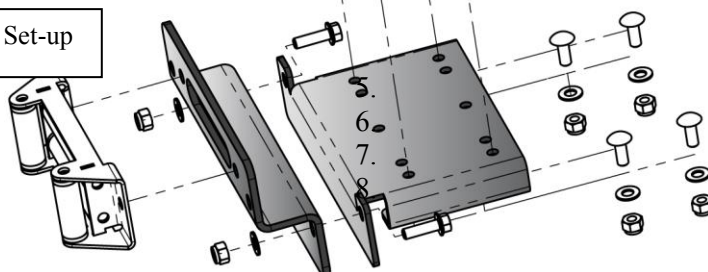

"Figure 4" 6.60" Wide Bolt pattern Set-up

9. You will need to put the supplied carriage bolts in the rectangle cut-outs that are on the bottom flanges of the mount plate (as shown in Figure 3&4) and then place the winch and mount assembly into location with the carriage bolts going through the frame holes on the machine as shown in Figure 5.

NOTE: This can be a tricky part of the install. You need to keep the carriage bolts in the rectangular cut-outs and at the same time you will need to get them thru the holes on the plate that is on your machine's frame.

There are many ways that can help with this step. (none of these are required, but they can help ease the install).

- You can remove the lower radiator plastic splash guard or even just loosen it.
- You can also tape the carriage bolt heads to the flange of the bracket to help keep them from popping out.

10. Once the winch assembly is in location and the carriage bolts are through the appropriate holes you can then assemble the washers and nylock nuts to the carriage bolts, but do not tighten at this time.

11. Replace the front bumper that was removed in Step 2.

12. Place the fairlead bracket into location as shown in Figure 6 (between the winch mount and the bumper frame) and assemble the winch mount to the fairlead bracket and bumper frame using the supplied 3/8" hardware.

13. Tighten the carriage bolts from Step 5.

14. Replace the front plastic bumper cover that was removed in Step 1.

15. Using the instructions provided with your winch, wire accordingly.

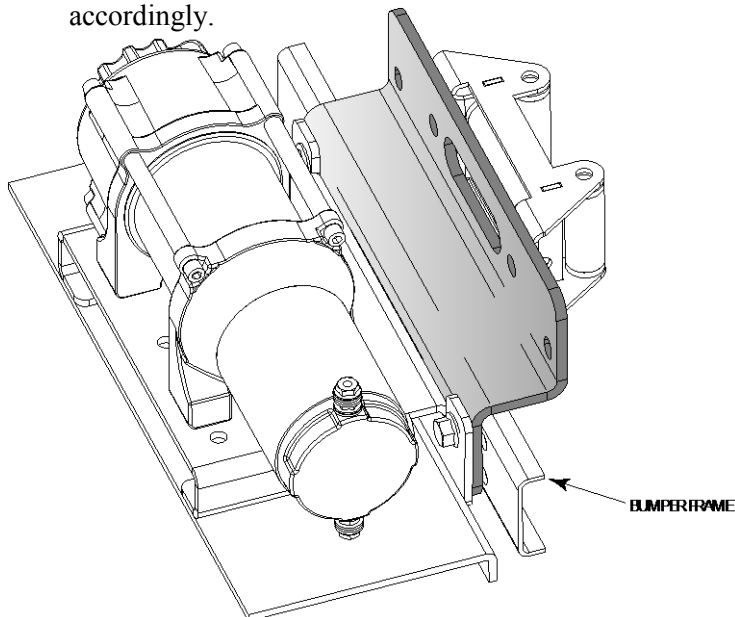

"Figure 6"
Fairlead Bracket in Position

Mini-Rocker Switch Hardware Kit

This allows you to mount your usual handle bar mounted switch to almost any desired location.

- a. Remove handlebar mount hardware from the switch.
- b. Locate desired mounting location
- c. Mark and drill two switch holes through dash using switch housing as a template
- d. Drill a 3rd hole for the switch wiring.
- e. Assemble per Figure 7

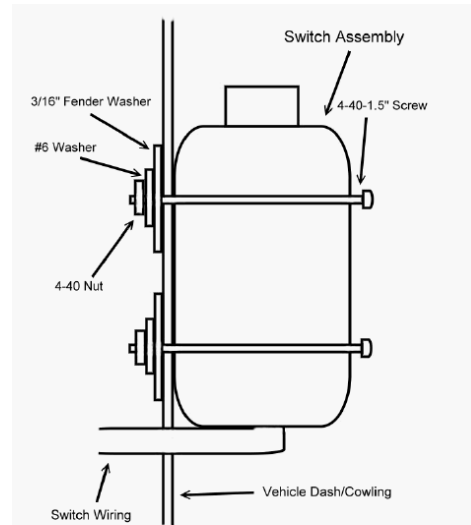

Optional Switch Mount Instructions*

"Figure 7" Mini-Rocker Mounting



"Figure 5"
Winch Mount Assembly in Position

