



## **ARTIC CAT WINCH MOUNT (MA11961)**

*2005 400 Automatic 4x4 TBX*

*2006 400i Automatic 4x4*

*All 2005 500's except the Twin*

*All 2005-2006 650's except the Prowler*

### **HARDWARE FOR WINCH MOUNT KIT**

<b>QTY</b>	<b>DESCRIPTION</b>
1	Winch Mount Plate
5	5/16"-18 x 1-1/4" Bolt
2	5/16"-18 x 1" Bolt
2	8 MM x 16 Hex Head Bolt
6	5/16 Nylock nuts
2	5/16" Lock Washers
2	5/16" Washers

### **MOUNTING INSTRUCTIONS**

\*\*\*All directions referring to right and left are when the rider is sitting on the ATV

For Viper, Superwinch, Cycle Country and other 2-bolt winches, use the two 5/16" x 1" bolts & Nylock nuts to mount the winch to winch plate. Tighten. Be sure when mounting, the winch motor is to the left side. For Warn and Ramsey winches, use the four 5/16" x 3/4" bolts provided to mount the winch to the 4-bolt pattern in the center of the mount plate. Your motor should be on the right side of the vehicle.

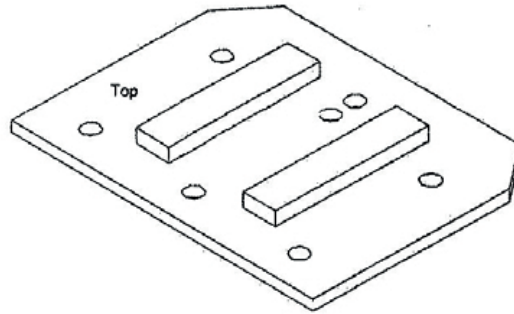

### INSTALLATION INSTRUCTIONS

1. Remove plastic skid plate.
2. Slid the winch mount plate in on top of the horizontal portions of the front frame pipe. Place the (4) 5/16"-18 x 1 1/4" Bolts in the four corner holes from the top down.
3. Hand work bolts through the 4 factory provided holes and hand tighten to the 4 Nylock nuts provided in the kit.
4. Slide winch into ATV from the right side motor side first. Winch motor should mount on left side of ATV. Viper uses a 2 bolt mount. Slide the 5/16"-18 x 1" mounting bolt with washer through the Viper slotted mount plate and though the winch mount plate and hand tighten the 2 Nylock nuts. Flat washers will reside on top of the slotted hole on the Viper winch plate. One bolt goes top down while the back bolt goes bottom up.
5. Mount the Fairlead to the 8MM threaded holes provided by the factory. Work cable through the fairlead by going to free spool position. Do not attempt free spool with tension on the cable. Hold the drum while going to free spool, as new cable will unwind easily. Attach the cable hook.
6. Replace skid plate.
7. The next step is to install the contactor (control relay). There is no right or wrong place. We recommend a dry place away from sharp or moving suspension parts, knowing that it is hard to find a totally dry place on an ATV. You may mount it in the front or back or under the seat. You may mount it with U-bolts (holes on contactor are metric.) or bolts. On this model we installed the contactor in the rear storage compartment because it is dry there. We attached all the wires before bolting it down. We do offer an optional side bracket mount. This bracket allows the contactor to hang on the side of square tubing. There is an additional cost associated with this part, just call us for details.
8. Now the power wires can be run. Take the long set of red/black power wires and attach the red wire to the winch's red terminal and the black wire to the silver terminal. Keep the wire away

from moving suspension parts. We left wire loose as we went down the upper frame. When fastening any wire where moisture could cause problems put dielectric tune-up grease (Permatex 22058 from NAPA) on all connections. Also if you want extra vibration protection Napa has plastic split tube conduct that can also be installed over the wire after it has been routed through the frame. Connecting the wire to the contactor, you will want the red wire attached to the red nut on winch motor to go to the blue terminal on contactor. (Blue is painted on top of contactor terminal). The black wire attached to the silver terminal on winch goes to the yellow terminal on contactor. If you get this wiring backwards this will not damage anything, the control switch on handlebars will just work in reverse.

9. Next run the power wires from the battery into the compartment or location you have chosen for your contactor. The red wire goes to the positive terminal on the battery and the red terminal on the contactor. The black wire goes negative terminal on the battery and the black terminal on contactor. We didn't attach the red wire until all the rest of the wiring was complete. Caution! It is easier to reverse the polarity at the battery then you would think and that can cause damage to your voltage regulator, contactor, and can start fires. The battery is capable of supplying a lot of current even to a short.
10. The last of the wiring is to mount and wire in the control switch on the handle bars. We wrapped a couple wraps of electrical back tape on the handle bars before we clamped the switch down. Remove the center plastic cover that holds the key switch. The cover for the screws pops off with a flat blade screw driver. Remove the two screws with a Phillips screw driver. Pull up on the cover exposing the rear underneath the key switch. Route the control wiring down the vertical wiring harness and join up with the power cable on left side of cowling. Keep the red wire that hangs out near the back of key switch. Route the control wire down to the power wire and follow the power wire back to the contactor location. Fasten the green wire to the green wire on contactor and black wire to the black wire on the contactor. (The connectors are gender specific and can't be reversed.)
11. The red switch control wire is the next item, which often raises some questions. The red control wire hanging out of the control cable near the switch goes to the switch 12 volts on the ATV. Some ATV's will have an accessory wire provided and it is spelled out in the owner's manual. The wire will be fused for it. The wires can be many different colors. You could also call an Arctic Cat Service Center & they will give you the location and color wire for winch control switch 12 volts over the phone. A factory service manual will also have the schematic in it. We found the switch 12 volts by using a 12 volt test light. We poked a hole through the insulation. With the test light clipped to the frame we turned on the key and lit the light. We turn turned off the key and light went out. (Switched 12 volts is defined as 12 volts is removed with the key off, as opposed to battery 12 volts that has power all the time. You can always find switch 12 volts on the back side of the ignition switch.) We found a blue with an orange tracer wire. You may obtain a crimp on side tape terminal for taping into insulated wire at an Auto parts store or hardware store. We bared the insulation and soldered the red wire to the blue/orange wire. We used RTV Silicone on the joint and wrapped it in electrical tape.
12. Lastly, fasten down the contactor with the bolts provided in the winch box. Make sure the 10 MM terminal nuts are tight on the contactor and wire terminal lugs and not shorting. Double check the green and black control wires on the contactor. They can mate hard, so make sure they

are seated. Then, attach the battery wires to the battery. Your winch is operational. With the ignition key on, the relay should click when the handle bar control switch is activated. You should test both halves of the switch. The click is independent of switch 12 volts. It will click even if the battery is not wired to the contactor or winch. Wind in excess winch steel cable by carefully guiding it to the spool. Installation technicians are available to answer questions that may arise.