



motoalliance

MOTOALLIANCE WINCH MOUNT

MA11981

Kubota RTV 900/1140

Thank you for purchasing our MotoAlliance winch mount. You now own a premium custom winch mount allowing you to use your winch with your ATV / SxS. Please note the following instructions and heed all warnings.

- **Please use common sense when operating your ATV / SxS**
- **Read your Winch Operator's Manual and all other Operator Manuals including warning labels, before operating your ATV / SxS**
- **Be observant of moving parts causing entanglement use extreme caution!**

SEVERE INJURY OR DEATH MAY RESULT IF YOU ARE NEGLIGENT.

Please verify that all hardware and parts are included in your package.

Kit Content:

Item Number	Description	Quantity
1	MA11981-1 Main Mounting Bracket	1
2	MA11981-2 Mounting Spacers	2
3	M8 Flat Washer	4
4	M8 Lock Washer	4
5	M8-1.25 x 40mm Hex Head Bolt	4

Exploded View

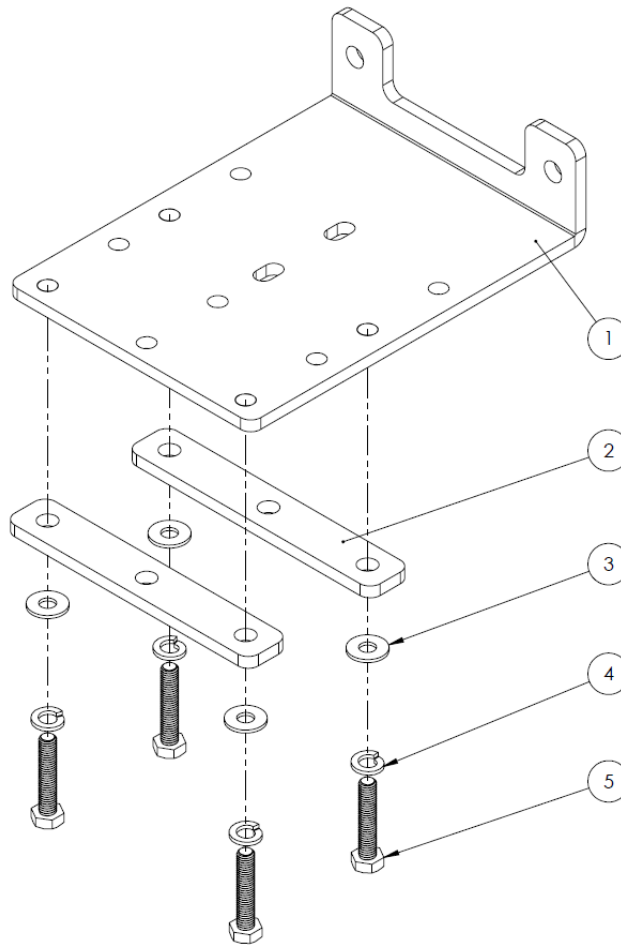

Figure 1

1. Open the hood and access the winch cavity.
2. If the winch includes a Rubber Line Stopper, remove the steel cable or synthetic rope from the winch and set aside.
3. Place the MA11981-2 Mounting Spacers into the winch cavity, making sure the holes line up with the holes in your machine.
4. Slide the MA11981-1 Main Mounting Bracket in through the front of the winch cavity and place it on top of the MA11981-2 Mounting Spacers.
5. Place the winch into the winch cavity, aligning the holes from the winch with the holes in the machine and the MA11981-2 Mounting Spacers, and the MA11981-1 Main Mounting Bracket as shown in Figure 2.

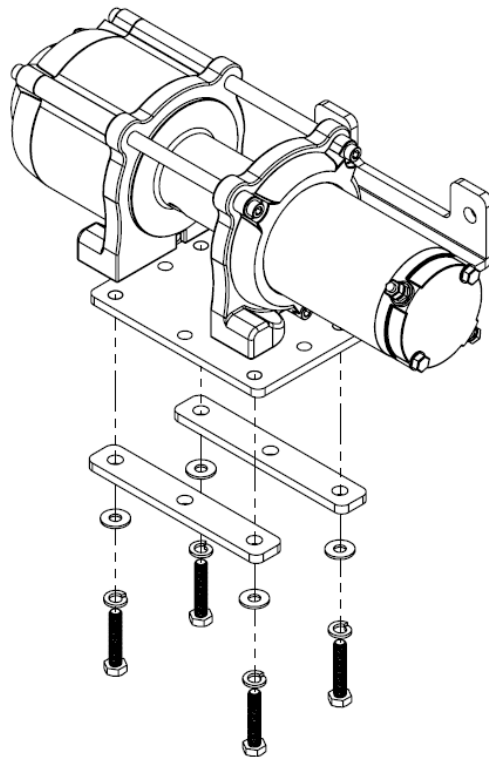

Figure 2

6. Use the provided M8 Hardware to mount up through your machine and mounting plates and into your winch as shown in Figure 3.
7. Once the winch is mounted securely, attach the Roller Fairlead or Aluminum Hawse fairlead to the front of the MA11981-1 Main Mounting Bracket.
8. Pass the cable through the Rubber Line Stopper and then through the Roller Fairlead or Aluminum Hawse. Leave the cable unattached at this point. After the winch is fully installed, reattach the cable to the winch. Leave the cable unwound as it will be wound under load to properly set the cable. See Figure 3.

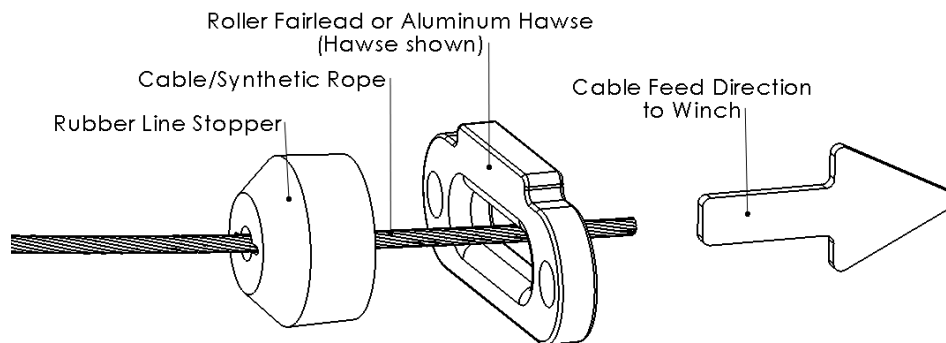

Figure 3

9. Follow the instructions in your Winch manual to wire up your winch.
10. Kubota provides a mounting location for the contactor under the driver's seat but depending on the style of contactor in your winch you may need to redrill the mounting holes or mount the contactor elsewhere.
11. Once the winch is wired up properly, tie the end of the cable off to a secure location (such as a tree, a post, or a full sized truck), set the brake on the machine and wind the winch in carefully (following the duty cycle noted in your winch operations manual), watching to make sure the cable doesn't become tangled. This will help set the cable and prevent future tangles.