

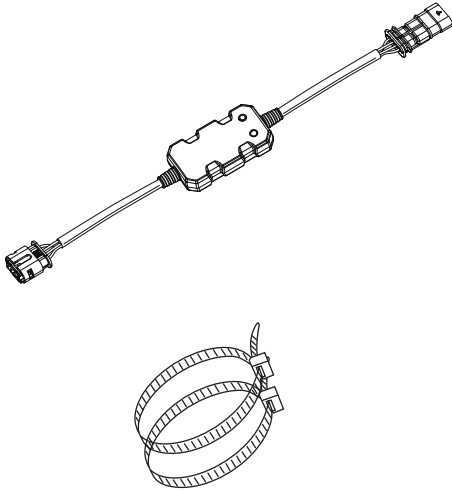

Quick Start Guide

AXON WARN® HUB RECEIVER

KIT CONTENTS



BEFORE YOU BEGIN

1.

Download the WARN® HUB App from the App Store or Google Play.

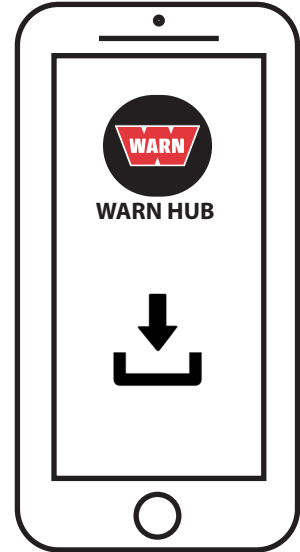

Data rates may apply.
Apple is a trademark of Apple Inc., registered in the U.S. and in other countries. App Store is a service mark of Apple Inc.
Google Play is a trademark of Google Inc.

MOUNT



2.

Determine mounting location and wire routing path.

Recommendation: Under vehicle hood, on vehicle frame or along other wiring bundles. Avoid sharp edges, heat and moving parts.

3.

Using the included zip-ties, mount HUB Receiver firmly to vehicle.

4.

Route the plug ends of the HUB to the vehicle accessory wire harness connections. **NOTE: Make sure to route wires/cables away from sharp edges, heat and moving parts.**

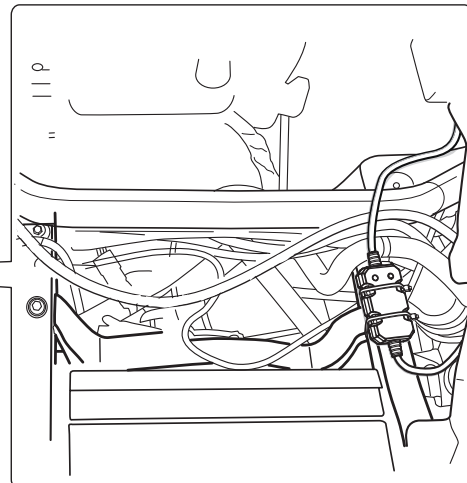
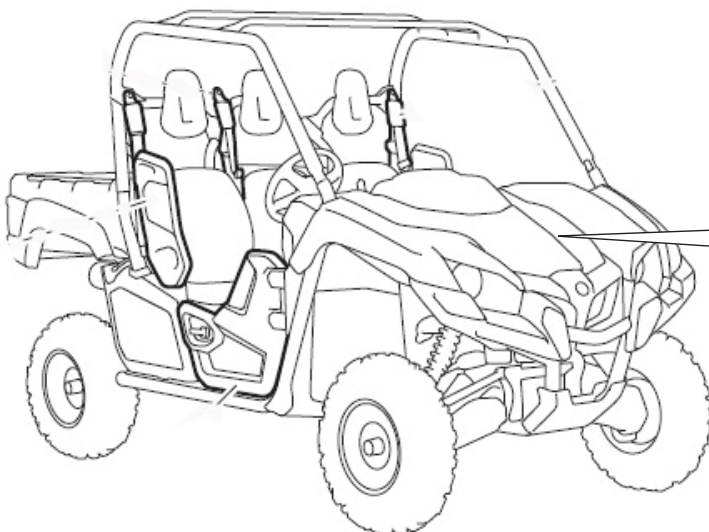

NOTE: Zip tie cables to vehicle in regular intervals to keep cables secure and in place.



Quick Start Guide

AXON WARN® HUB RECEIVER

WIRE

5.

- Disconnect the vehicle accessory wire harness from the winch control switch.
- Plug one HUB Receiver connector into the winch control switch.
- Plug remaining HUB Receiver connector into the accessory wire harness.

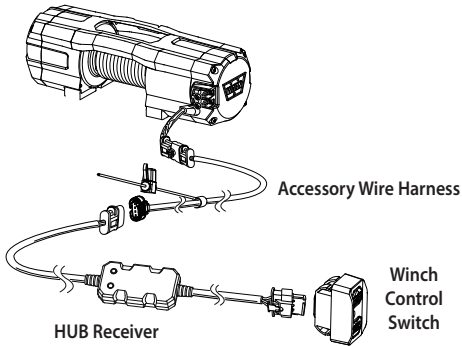

NOTE: Image shows HUB Receiver connection at switch. The HUB Receiver is also adaptable to winch connection if preferred.

POWER

6.

Turn vehicle power on.

NOTE: The HUB Receiver is active when the yellow light is on.

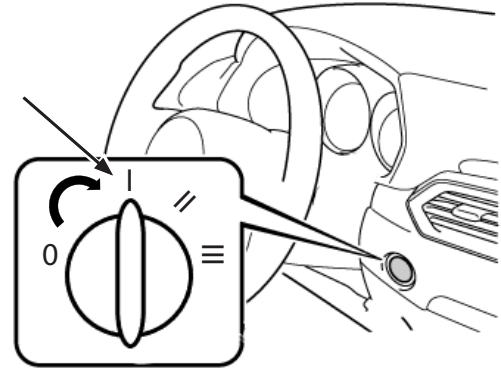

PAIR/CONNECT

7.

Press and hold button on HUB Receiver until blue light flashes (approximately 2 seconds) and then release button.

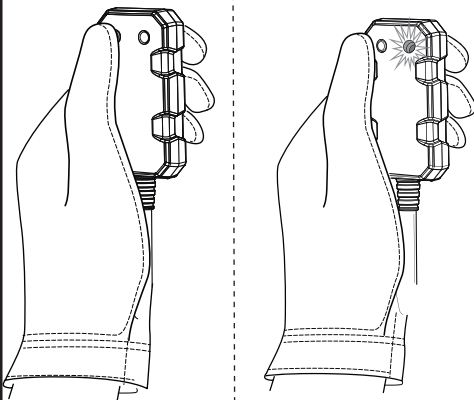

8.

Open app on phone and follow prompts.



9.

When light on the HUB Receiver turns green, you are connected.

Continue following the instructions through your app.

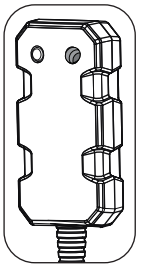
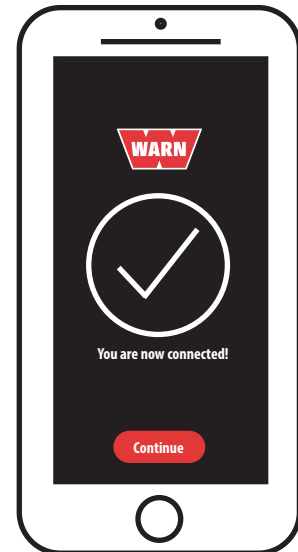



WARN® HUB Receiver



General Safety/ Tips/Trouble Shooting/ Customer Service Guide







Always Know Your Winch. Take time to fully read these instructions, your quick start guide and the Basic Guide to Winching Techniques, in order to understand your product operations.

 WARNING

• For winch applications only. Do not use with a hoist product.

 CAUTION	
	
MOVING PARTS ENTANGLEMENT HAZARD	
Failure to observe these instructions could lead to minor or moderate injury.	
To avoid injury to hands or fingers:	
<ul style="list-style-type: none"> • Never leave the Hub Receiver plugged in when installing, freespooling, rigging, servicing or when the winch is not being used. * Always keep hands clear of winch rope, hook loop, hook and fairlead opening during installation, operation, and when spooling in or out. 	

 WARNING		
		
		
CHEMICAL AND FIRE HAZARD		
Failure to observe these instructions could lead to serious injury or death.		
<ul style="list-style-type: none"> • Always remove jewelry and wear eye protection. • Never route electrical cables across sharp edges. • Never route electrical cables near parts that get hot. • Never route electrical cables through or near moving parts. • Always place the supplied terminal boots on wires and terminals as directed by the installation instructions. • Never lean over battery while making connections. • Never route electrical cables over battery terminals. • Never short battery terminals with metal objects. • Always verify area is clear of fuel lines, fuel tank, brake lines, electrical wires, etc., when drilling. • Always consult operator's manual for proper wiring details. • Always insulate and protect all exposed wiring and electrical terminals. • Always connect red (+) power cable ONLY to the positive (+) terminal of the battery. • Always connect black ground (-) power cable ONLY to the negative (-) terminal of the battery. 		

 NOTICE
<ul style="list-style-type: none"> • For Truck/SUV Hub Receiver Only: Avoid vehicle battery drain by unplugging the remote plug from winch and secure up and out of the way, when not in use.

FCC Regulation

This device complies with Part 15 of the FCC Rule. Operation is subject to the following two conditions:

- (1) this device may not cause harmful interference, and
- (2) this device must accept any interference received, including interference that may cause undesired operation.

This equipment has been tested and found to comply with the limits for a Class B digital device, pursuant to part 15 of the FCC Rules. These limits are designed to provide reasonable protection against harmful interference in a residential installation. This equipment generates, uses and can radiate radio frequency energy, and if not installed and used in accordance with the instructions, may cause harmful interference to radio communications. However, there is no guarantee that interference will not occur in a particular installation. If this equipment does cause harmful interference to radio or television reception, which can be determined by turning the equipment off and on, the user is encouraged to try to correct the interference by one or more of the following measures:

- Reorient or relocate the receiving antenna.
- Increase the separation between the equipment and receiver.
- Connect the equipment into an outlet on a circuit different from that to which the receiver is connected.
- Consult the dealer or an experienced radio/TV technician for help.

§ 15.21 Information to user.

The users manual or instruction manual for an intentional or unintentional radiator shall caution the user that changes or modifications not expressly approved by the party responsible for compliance could void the user's authority to operate the

equipment. In cases where the manual is provided only in a form other than paper, such as on a computer disk or over the Internet, the information required by this section may be included in the manual in that alternative form, provided the user can reasonably be expected to have the capability to access information in that form.

Industry Canada

This device complies with Industry Canada license-exempt RSS standard(s). Operation is subject to the following two conditions:

- (1) this device may not cause interference, and
- (2) this device must accept any interference, including interference that may cause undesired operation of the device.

Under Industry Canada regulations, this radio transmitter may only operate using an antenna of a type and maximum (or lesser) gain approved for the transmitter by Industry Canada. To reduce potential radio interference to other users, the antenna type and its gain should be so chosen that the equivalent isotropically radiated power (e.i.r.p.) is not more than that necessary for successful communication.

This radio transmitter (identify the device by certification number, or model number if Category II) has been approved by Industry Canada to operate with the antenna types listed below with the maximum permissible gain and required antenna impedance for each antenna type indicated. Antenna types not included in this list, having a gain greater than the maximum gain indicated for that type, are strictly prohibited for use with this device.

Tips/Features

Pairing a second receiver

1. Open Settings on smart device.
2. Click 'My HUB Receivers'
3. Click 'Pair a HUB Receiver'
4. Complete pairing following Pair/Connect section in quick start.

Reset receiver

1. Hold button for 10 seconds until blue light on the HUB receiver rapidly flashes.
2. Release button.
3. Forget receiver. **NOTE: Follow your smart device's manufacturers instructions to forget bluetooth pairing.**
4. Follow Pair/Connect instructions in Quick Start Guide to reconnect your smart device to the HUB receiver.

LED Light Key

Yellow: Receiver has power but not paired/connected.

Blue:
 Slow flashing: Receiver is in pairing mode.
 Fast flashing: Receiver has been reset.

Green: Receiver is on and paired/connected.

Trouble Shooting/Error Conditions

Problem	Possible cause	Corrective action
Winch is not operating	No power to HUB Receiver	<ul style="list-style-type: none"> • Turn vehicle on. • Confirm all wiring connections (<i>contactor, control pack, ground wire</i>) are correct and secure. • Confirm vehicle battery connections are correct and secure. • Confirm winch remote plug is connected (<i>if applicable</i>).
	No connection between HUB App and HUB Receiver	<ul style="list-style-type: none"> • Verify HUB Receiver's LED is green. <i>Refer to Quick Start Guide.</i>
Winch only operates in one direction	Winch overheated (AXON only)	<ul style="list-style-type: none"> • Stop winching and let winch cool.
	Winch overload (AXON only)	<ul style="list-style-type: none"> • Release/lighten load.
	Improper wiring (Universal only)	<ul style="list-style-type: none"> • Confirm wiring is correct and secure. See Step 3 Wiring HUB Receiver. <i>Refer to Quick Start Guide.</i>
Intermittent operation	Poor signal	<ul style="list-style-type: none"> • Get closer. • Relocate receiver away from any obstructions (<i>e.g., batteries, engines</i>). • Maintain line of sight to vehicle with receiver. • Avoid sources of radio interference (<i>e.g., power lines, other radios</i>).
	Low battery voltage	<ul style="list-style-type: none"> • Be sure to allow vehicle to charge before using. • Check battery connections.
	Receiver connected to winch with solenoid control pack	<ul style="list-style-type: none"> • The WARN HUB receiver is not designed for continuous use with some legacy solenoid control packs.
	HUB overheating	<ul style="list-style-type: none"> • Move HUB to a cooler location on vehicle.
LED indicator is not green	Receiver is not paired	<ul style="list-style-type: none"> • See Pair/Connect section in Quick Start Guide.

Problem	Possible cause	Corrective action
Receiver will not pair or connect	Smart device is out of range	<ul style="list-style-type: none"> • Move closer to the receiver.
	Interference with an other device	<ul style="list-style-type: none"> • Disconnect from other bluetooth devices.
	Bluetooth turned off on smart device	<ul style="list-style-type: none"> • Follow device owner's manual to turn on Bluetooth.
	Disrupted pairing	<ul style="list-style-type: none"> • Reset receiver. <i>See Tips and Features on page 2.</i> • Repair/connection.
	App is not open	<ul style="list-style-type: none"> • Open app.
	Someone else is connected	<ul style="list-style-type: none"> • Disconnect any other smart devices from receiver.
	Power is off	<ul style="list-style-type: none"> • Turn vehicle power on. • Plug HUB receiver into winch remote socket.

Maintenance

Check	Before first operation	After each use	Every 90 days
Take time to fully read the Instructions and/or Operations Guide, and/or Basic Guide to Winching Techniques, in order to understand your winch and its operations	X		
Check zip ties and make sure they are tight. Replace if damaged.	X		X
Verify wiring to all components is correct and be certain that all connections are tight.	X		X
Verify there is no exposed/bare wiring, terminals or cable insulation damage (chafing/cutting). Cover any exposures with terminal boots. Repair or replace damaged electrical cable.	X		X
Unplug winch remote plug (Truck/SUV only)		X	