



Winch Installation Guide

Every winching situation has the potential for personal injury. In order to minimize that risk, it is important to read this guide and The Basic Guide to Winching Techniques carefully. Please familiarize yourself with the operation of your winch before using it and be constantly safety oriented. In this guide we provide important safety information and instructions on how to install your winch. Please read the Basic Guide to Winching Techniques for information on how to properly use your winch and proper rigging techniques.

Please keep this manual and other product literature found in this kit for future reference. In this kit you will find the following pieces of literature: Winch Installation Guide, Basic Guide to Winching Techniques, Specification and Performance Data, Product Warranty, Replacement Parts List and other product literature specific to some products.

SYMBOL	EXPLANATION
	Read All Product Literature
	Always Wear Hearing and Eye Protection
	Never Use Winch as a Hoist
	Properly Seat Load in Throat of Hook
	Wind Rope on Bottom of Drum
	Finger/Fairlead Crushing Hazard
	Hand Piercing/Cutting Hazard
	Explosion/Bursting Hazard
	Never Route Electrical Cables through Sharp Edges Hazard
	Avoid Installing Electrical Cables around Pinch and Wear/Abrasion Points

SYMBOL	EXPLANATION
	Always Wear Leather Gloves
	Do Not Move People
	Always Use Supplied Hook Strap
	Never Apply Load to Hook Tip or Latch
	Never Wind Rope Over Top of Drum
	Fairlead Pinch Point
	Hot Surface Hazard
	Fire and Burn Hazard
	Never Route Electrical Cables through or near Moving Parts Hazard
	Exposed Wiring Hazard, Insulate Exposed Wiring and Terminals
	Never Hook Back on Rope

Warnings and Cautions



As you read these instructions, you will see WARNINGS, CAUTIONS, NOTICES and NOTES. Each message has a specific purpose. WARNINGS are safety messages that indicate a potentially hazardous situation, which, if not avoided could result in serious injury or death. CAUTIONS are safety messages that indicate a potentially hazardous situation which, if not avoided, could result in minor or moderate injury. A CAUTION may also be used to alert against unsafe practice. CAUTIONS and WARNINGS identify the hazard, indicate how to avoid the hazard, and advise of the probable consequence of not avoiding the hazard. NOTICES are messages to avoid property damage. NOTES are additional information to help you complete a procedure. **PLEASE WORK SAFELY!**

WARNING		
MOVING PARTS ENTANGLEMENT HAZARD Failure to observe these instructions could lead to serious injury or death.		
<ul style="list-style-type: none"> • Always ensure hook latch is closed and not supporting load. • Never apply load to hook tip or latch. Apply load only to the center of hook. • Never use a hook whose throat opening has increased, or whose tip is bent or twisted. • Always use a hook with a latch. • Always ensure the operator and bystanders are aware of the stability of the vehicle and/or load. • Always keep wired remote control lead and power cord clear of the drum, rope, and rigging. Inspect for cracks, pinches, frayed wires or loose connections. Damaged components must be replaced before operation. • Always pass remote lead thru window when used in vehicle. • Never hook back on rope. 		

WARNING	
MOVING PARTS ENTANGLEMENT HAZARD Failure to observe these instructions could lead to serious injury or death.	
General Safety: <ul style="list-style-type: none"> • Always Know Your Winch. Take time to fully read the Instructions and/or Operations Guide, and/or Basic Guide to Winching Techniques, in order to understand your winch and its operations. • Never exceed winch or winch rope rated capacity. Double line using a snatch block to reduce winch load. • Always wear heavy leather gloves when handling winch rope. • Never use winch or winch rope for towing. Shock loads can damage, overload and break rope. • Never use a winch to secure a load. • Never operate this winch when under the influence of drugs, alcohol or medication. • Never operate this winch if you are under 16 years of age. 	
Installation Safety: <ul style="list-style-type: none"> • Always choose a mounting location that is sufficiently strong to withstand the maximum pulling capacity of your winch. • Always use class 8.8 metric (grade 5) or better hardware. • Never weld mounting bolts. • Always use factory approved mounting hardware, components, and accessories. • Never use bolts that are too long. • Always complete the winch installation and hook attachment before installing the wiring. • Always keep hands clear of winch rope, hook loop, hook and fairlead opening during installation, operation, and when spooling in or out. • Always position fairlead with warning readily visible on top. • Always prestretch rope and respool under load before use. Tightly wound rope reduces chances of "binding", which can damage the rope. 	

WARNING	
MOVING PARTS ENTANGLEMENT HAZARD Failure to observe these instructions could lead to serious injury or death.	
Winching Safety: <ul style="list-style-type: none"> • Always inspect winch rope, hook, and slings before operating winch. Frayed, kinked or damaged winch rope must be replaced immediately. Damaged components must be replaced before operation. Protect parts from damage. • Always remove any element or obstacle that may interfere with safe operation of the winch. • Always be certain the anchor you select will withstand the load and the strap or chain will not slip. • Always use supplied hook strap whenever spooling winch rope in or out, during installation and during operation. • Always require operators and bystanders to be aware of vehicle and or load. • Always be aware of stability of vehicle and load during winching, keep others away. Alert all bystanders of an unstable condition. • Always unspool as much winch rope as possible when rigging. Double line or pick distant anchor point. • Always take time to use appropriate rigging techniques for a winch pull. • Never touch winch rope or hook while someone else is at the control switch or during winching operation. • Never engage or disengage clutch if winch is under load, winch rope is in tension or drum is moving. • Never touch winch rope or hook while under tension or under load. • Always stand clear of winch rope and load and keep others away while winching. • Never use vehicle to pull load on winch rope. Combined load or shock load can damage, overload and break rope. • Never wrap winch rope back onto itself. Use a choker chain or tree trunk protector on the anchor. 	

WARNING	
FALLING OR CRUSHING HAZARD Failure to observe these instructions could lead to serious injury or death.	
<ul style="list-style-type: none"> • Always stand clear, keep hands clear, keep others away. • Never operate winch with less than 5 wraps of rope around the drum. Rope could come loose from the drum, as the rope attachment to the drum is not designed to hold a load. • Never use winch as a hoist or to suspend a load. • Always be certain anchor will withstand load, use appropriate rigging and take time to rig correctly. • Never use winch to lift or move persons. • Never use excessive effort to freespool winch rope. • Always use proper posture/lifting technique or get lifting assistance while handling and installing product. • Always spool the rope onto the drum in the direction specified by the winch warning label on the winch and/or documentation. This is required for the automatic brake (if so equipped) to function properly. • Always spool the winch rope onto the drum as indicated by the drum rotation label. 	

WARNING	
CUT AND BURN HAZARD Failure to observe these instructions could lead to serious injury or death.	
To avoid injury to hands and fingers: <ul style="list-style-type: none"> • Always wear heavy leather gloves when handling winch rope. • Always be aware of possible hot surfaces at winch motor, drum or rope during or after winch use. 	

! WARNING



CHEMICAL AND FIRE HAZARD
 Failure to observe these instructions could lead to serious injury or death.

- Always remove jewelry and wear eye protection.
- Never route electrical cables across sharp edges.
- Never route electrical cables near parts that get hot.
- Never route electrical cables through or near moving parts.
- Always place the supplied terminal boots on wires and terminals as directed by the installation instructions.
- Never lean over battery while making connections.
- Never route electrical cables over battery terminals.
- Never short battery terminals with metal objects.
- Always verify area is clear of fuel lines, fuel tank, brake lines, electrical wires, etc., when drilling.
- Always consult operator's manual for proper wiring details.
- Always insulate and protect all exposed wiring and electrical terminals.

! CAUTION

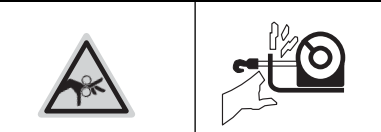

MOVING PARTS ENTANGLEMENT HAZARD
 Failure to observe these instructions could lead to minor or moderate injury.

To avoid injury to hands or fingers:

- Never leave remote control where it can be activated during free spooling, rigging, or when the winch is not being used.
- Never leave the winch remote control plugged in when installing, freespooling, rigging, servicing or when the winch is not being used.

NOTICE

AVOID WINCH AND EQUIPMENT DAMAGE

- Always avoid side pulls which can pile up winch rope at one end of the drum. This can damage winch rope or winch.
- Always ensure the clutch is fully engaged or disengaged.
- Always use care to not damage the vehicle frame when anchoring to a vehicle during a winching operation.
- Never submerge winch in water.
- Always store the remote control in a protected, clean, dry area.

! CAUTION



CUT AND BURN HAZARD
 Failure to observe these instructions could lead to minor or moderate injury.

- Never let winch rope slip through your hands.

Safety

When installing your ATV/UTV winch system, read and follow all mounting and safety instructions.

Always use caution when working with electricity and remember to verify that no exposed electrical connections exist before energizing your winch circuit.

For specifications and performance data, refer to the specification sheet supplied with your winch.

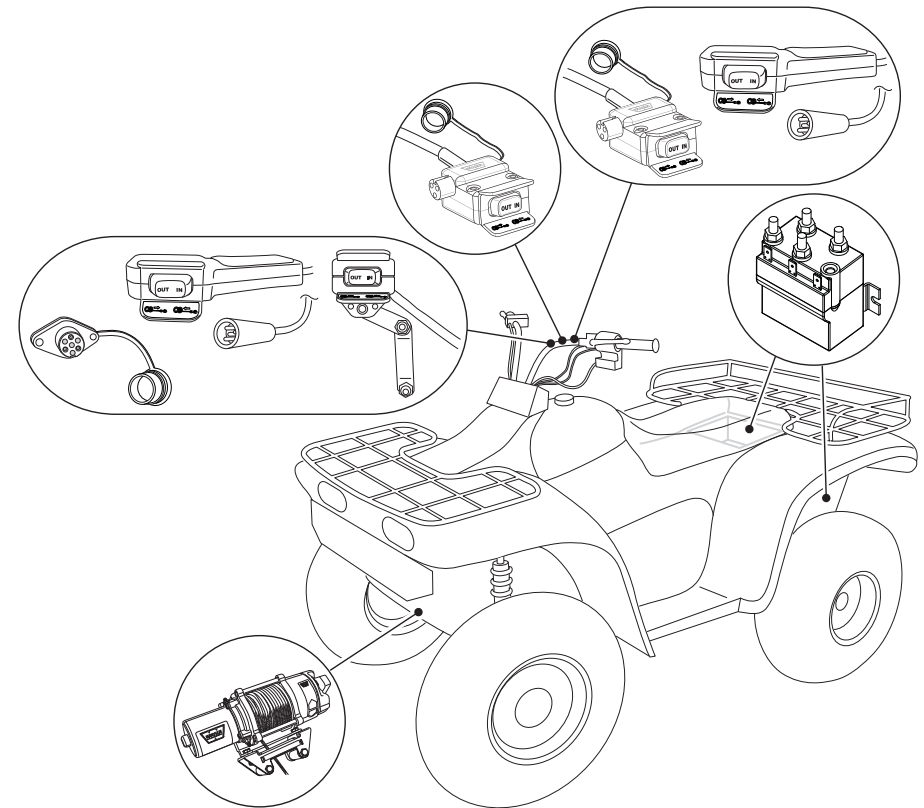

Figure 1: To install the complete kit, you will need to mount the winch, contactor handlebar mounted Mini-rocker switch and remote socket (optional on some models). Mounting locations may vary depending on make and model of the ATV/UTV. Read and understand the following instructions to choose the appropriate mounting locations.

MOUNTING

Step 1 - Mount the Winch

ATV/UTV winch mounting kits are available from your WARN Dealer to satisfy nearly all ATV/UTV applications. For information on available kits, contact your WARN product dealer.

NOTE: For optimal performance and the results you expect, WARN mounting plates are strongly recommended.

CAUTION To prevent accidental activation of the winch and serious injury, complete the winch installation and attach the hook before installing the wiring.

To secure the winch, always use:

- A flat, secure mounting location at least 4.8 mm (3/16 in.) thick.
- 8 mm (5/16 in.) Lock washers.
- M8-1.25 X 20 mm, class 8.8 hex head cap screws when using a one-piece winch mount plate.

NOTE: When using separate winch mount and fairlead plates use M8-1.25 X 25 mm class 8.8 hex head cap screws on the motor side of the base as shown in Figure 3.

1. Set winch in mounting location. Torque the mounting bolts to 16 N-m (12 lb-ft).
2. Remove bottom tie bolt. This bolt should be retained for winch service.

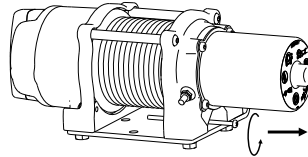

3. Remove elastic band retaining rope.
4. Put clutch in freespool position.
5. Manually feed cable loop through fairlead.
6. Attach hook to cable loop and re-engage clutch.

WARNING Always use supplied hook strap.

7. Install hook strap on hook.

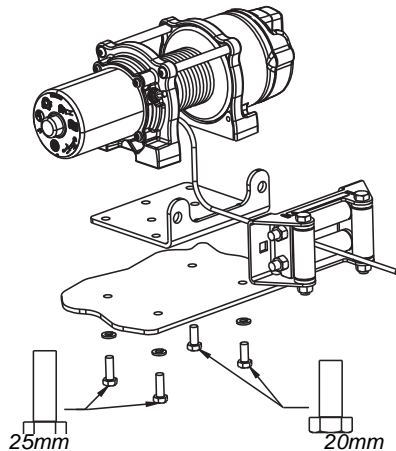
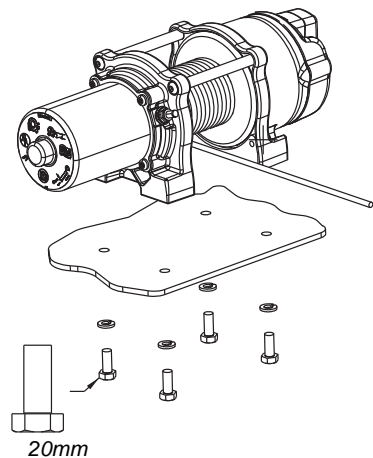

Figure 2 and 3: Orientation of winch to mounting plate and bolt lengths.

MOUNTING

Step 2 - Mount the Contactor

- Your new WARN winch can do a lot of work! This work is the conversion of electrical power into mechanical power. The contactor is the electromagnetic switch that controls the electrical power to your winch. The contactor must be correctly installed for it and the winch to work properly. The following instructions will assist you in the installation of your WARN contactor.

1. Disconnect the vehicle battery cables, negative terminal first. All work with electrical wires and cables must be completed with the battery completely disconnected from the vehicle wiring.

WARNING To prevent severe injury or death. Never lean over battery while making connections.

WARNING To prevent severe injury or death. Never route electrical cables over battery terminals.

WARNING To prevent severe injury or death. Never short battery terminals with metal objects.

2. It is recommended that the contactor be mounted close to the battery and in a location that is as clean and dry as possible.

WARNING! Do not mount on or near a heat source such as engine or exhaust. Ensure the selected location does not collect or retain water and the mounting of the contactor does not block drain holes. Exact location will vary depending on the ATV/UTV. Typical locations include inside, on top or on the side of rear storage box, under the seat or, on a few models, in front near battery.

3. Ensure the contactor mounting location selected provides sufficient clearance from all metal structures such as frame tubes. Do NOT place tools or other items in a position that might come in contact with the contactor posts.

WARNING To prevent severe injury or death. Always verify area is clear of fuel lines, fuel tank, brake lines, electrical wires, etc., when drilling.

4. Drill the mounting holes for the contactor and proceed to step three. Do NOT mount the contactor at this time.

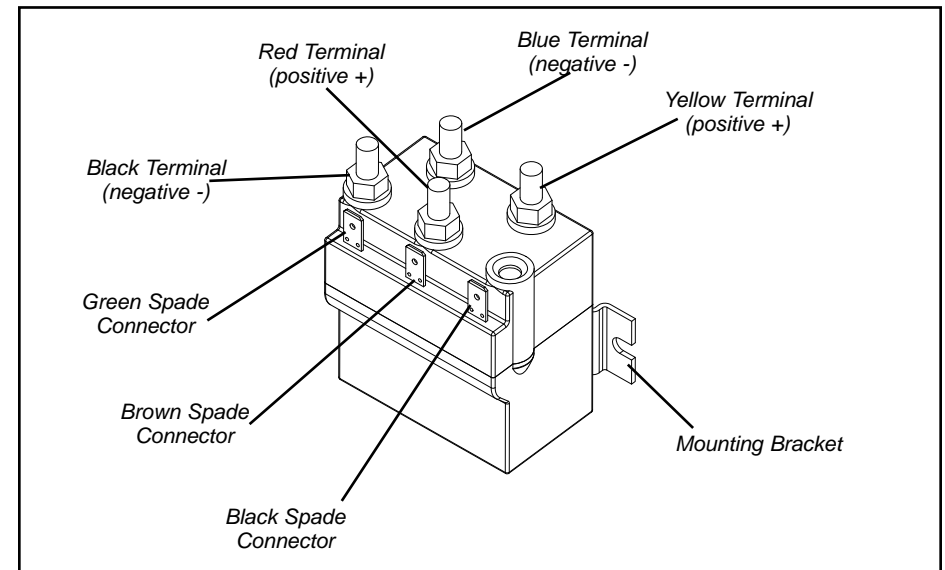





Figure 4. Contactor for the WARN ATV/UTV winch

MOUNTING

Step 3- Mount the Handlebar Switch

⚠ WARNING To prevent serious injury or death from electrical fire:

-  Never route electrical cables across sharp edges.
-  Never route electrical cables near parts that get hot.
-  Never route electrical cables through or near moving parts.
-  Avoid pinch and wear/abrasion points when installing all electrical cables.

⚠ WARNING To avoid injury and property damage: Use caution if moving or repositioning the ATV/UTV controls so as to not compromise the safe operation of the ATV/UTV. Select a mounting position that will provide clearance for all vehicle controls.

Before securing the switch cable with tie wraps, make sure that the handlebars have full range of motion.

1. Switch should be installed on the left handlebar. A piece of electrical tape around the handlebar will help prevent rotation of mount on the handle bar.
2. Do NOT tighten over any hoses or cables.

3. Once the handlebar switch is mounted, route the wire harness to where the contactor will be mounted.
4. Using the provided wire splice, splice the end of the red 20ga wire to a key controlled, fused, accessory circuit (power-point) of the ATV/UTV. The wire should only have power when the key is in the "ON" position.

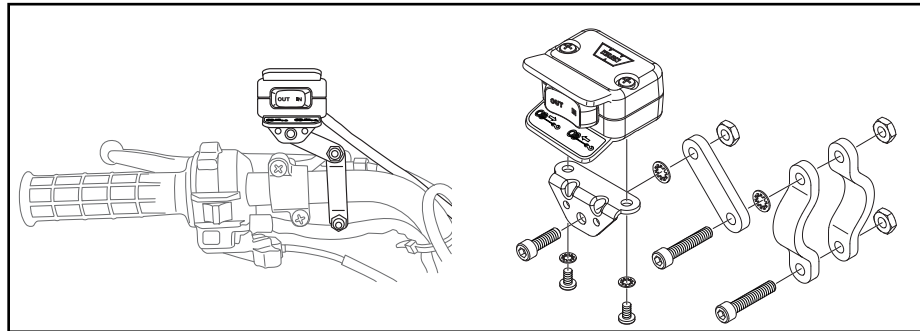
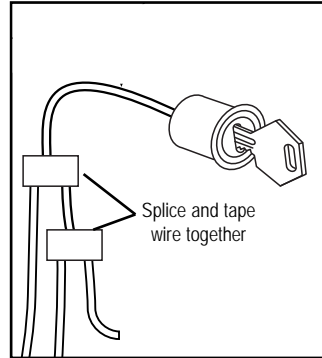

Figure 5: Handlebar Mount. Exact positioning may vary depending on the ATV/UTV make and model.





Figure 6: Mini-rocker switch assembly.

MOUNTING

Step 4 - Mount the Remote Socket (optional on some models)

⚠ WARNING To prevent severe injury or death. Always verify area is clear of fuel lines, fuel tank, brake lines, electrical wires, etc., when drilling.

⚠ WARNING To prevent serious injury or death from electrical fire:

-  Never route electrical cables across sharp edges.
-  Never route electrical cables near parts that get hot.
-  Never route electrical cables through or near moving parts.
-  Avoid pinch and wear/abrasion points when installing all electrical cables.

1. Determine the mounting location for the remote socket, drill three holes and install (see Figures 7 and 8).
2. Route the wire harness to where the contactor will be mounted.

3. Using the provided wire splice, splice the end of the red 20ga wire to a key controlled, fused, accessory circuit (power-point) of the ATV/UTV. The wire should only have power when the key is in the "ON" position.

NOTE: If installing both switches, both 20 gage red wires MUST be spliced to a key controlled accessory circuit of the ATV/UTV as described in step 4, page 9.

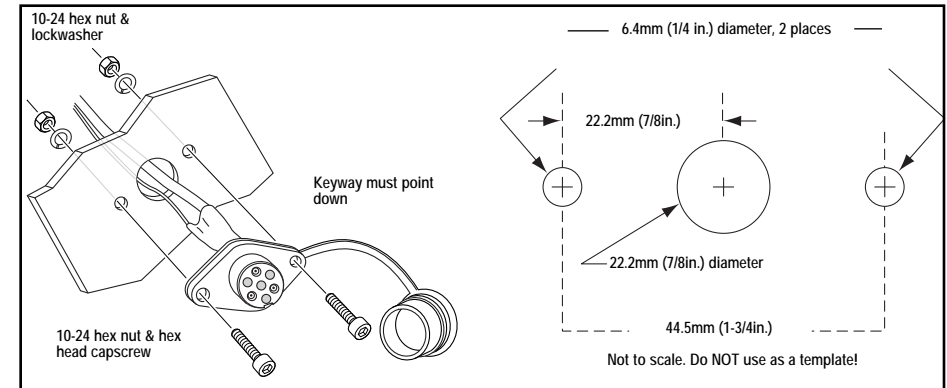





Figure 7 and 8. Remote socket installation

Step 5 - Mount the Dash Switch (optional on UTV models)

⚠ WARNING To prevent severe injury or death. Always verify area is clear of fuel lines, fuel tank, brake lines, electrical wires, etc., when drilling.

⚠ WARNING To prevent serious injury or death from electrical fire:

-  Never route electrical cables across sharp edges.
-  Never route electrical cables near parts that get hot.
-  Never route electrical cables through or near moving parts.
-  Avoid pinch and wear/abrasion points when installing all electrical cables.

1. Determine the dash mounting location for the dash switch (location is pre-determined on some specific models). Mount switch using bracket and supplied fasteners or cut rectangle slot as shown in Figure 10.
2. Route the wire harness to where the contactor will be mounted.

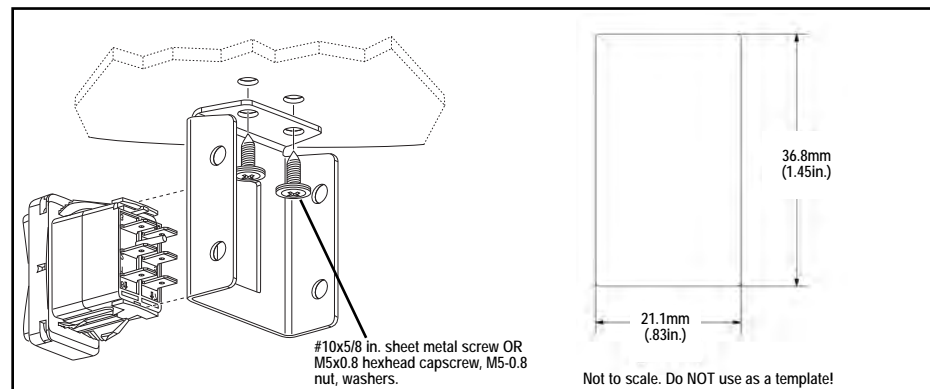

Figure 9 and 10 Dash Mount Installation





3. See wiring diagram provide, with contactor, for switch wiring detail.

NOTE: If installing both switches, both 20 gage red wires MUST be spliced to a key controlled accessory circuit of the ATV/UTV as described in step 4, page 9.

Step 6 - Install the Wiring

⚠ WARNING To prevent serious injury or death. Always place the supplied terminal boots on wires and terminals as directed by the installation instructions. All wires must be attached to the contactor before mounting the contactor to the ATV/UTV.

⚠ WARNING To prevent serious injury or death from electrical fire:

-  Never route electrical cables across sharp edges.
-  Never route electrical cables near parts that get hot.
-  Never route electrical cables through or near moving parts.
-  Avoid pinch and wear/abrasion points when installing all electrical cables.

⚠ WARNING Always insulate and protect all exposed wiring and electrical terminals.

1. Slip terminal boots on yellow and blue cable ends. See Figure 11 on following page.
2. Attach the yellow and blue electrical cables to the motor terminals on the winch. Yellow is marked #1 and blue is marked #2 on the motor. Torque the terminal nuts on the motor to 5.7 N-m (50 lb-in). Seat boots over terminal.
3. Route the yellow and blue electrical cables back to the contactor. Place boots over ring terminals. Place ring terminals on color coded contactor posts (yellow cable to yellow post, blue cable to blue post). Install and finger tighten nuts to retain ring terminals on contactor posts. Do NOT tighten nuts or seat boots at this time.
6. Install boots on ring terminal ends of red and black cables. Place ring terminals on color coded contactor posts (red cable to red post, black cable to black post). Install and finger tighten nuts to retain ring terminals on contactor posts. Do NOT tighten nuts or seat boots at this time. Route red and black cables to battery. Do NOT connect cables to battery at this time.
7. Mount the contactor to the location planned in Step 3. Tighten contactor mounting fasteners to 5.7 N-m or 50 lb-in.

8. Adjust cables to facilitate orderly and straight routing of the cables from the contactor. Avoid kinks or sharp bends in cables. Avoid crossing cables over each other for at least the first 6" (152mm) of cable starting from the contactor post. Torque the contactor terminal nuts to 4.5 N-m or 45 lb-in. Seat boots over ring terminals and posts.

9. Carefully inspect battery and winch electrical cable routing. Is it neat and tidy? **WARNING! Always route and secure electrical cables away from sharp edges, away from moving parts and away from sources of heat.** Zip tie and secure electrical cables and wiring harness. Zip ties should be snug, but not cutting into wire insulation. Use electrical tape, pieces of rubber hose or electrical conduit to protect electrical cables and wire harness where needed to avoid electrical cable insulation wear or abrasion.

10. Attach battery cables, red (positive) cables FIRST, black (negative) second. Install boots as appropriate to protect connection. Torque battery terminal fastener as directed by vehicle service manual.

ELECTRICAL CONNECTIONS

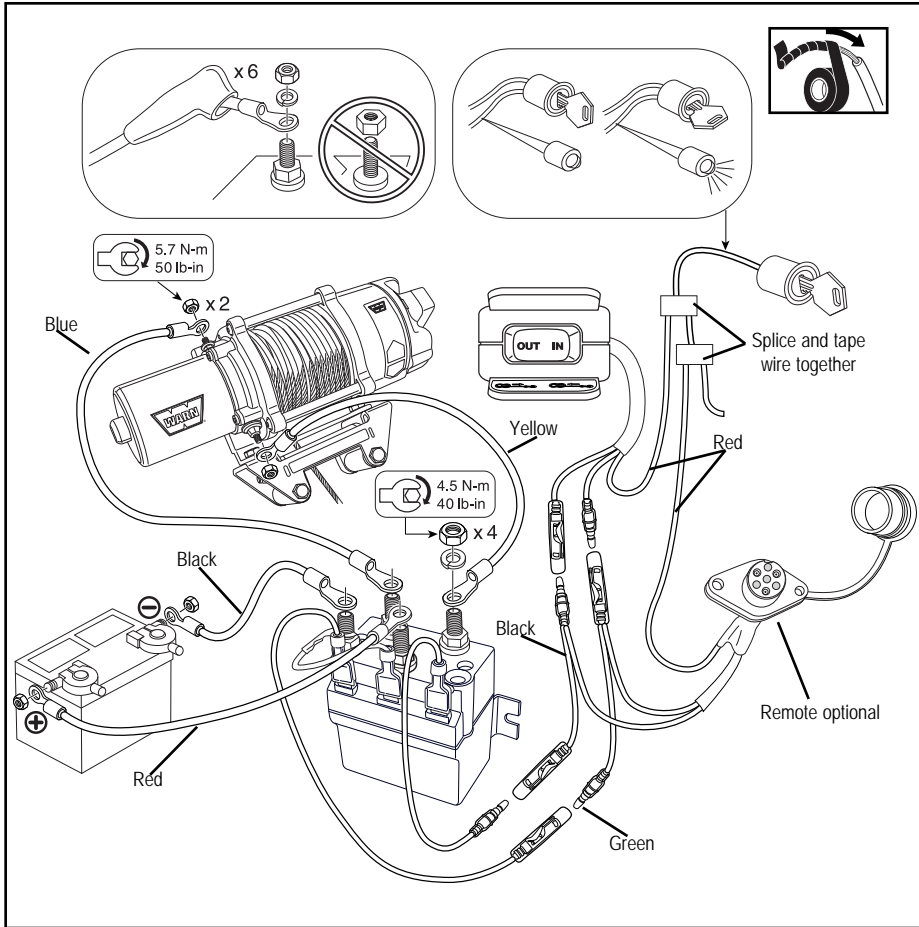

Figure 11. Wiring Installation diagram

SYSTEM CHECK

Check	Before first operation	After each use	Every 90 days
Take time to fully read the Instructions and/or Operations Guide, and/or Basic Guide to Winching Techniques, in order to understand your winch and its operations	X		
Check fasteners and make sure they are tight and to proper torque. Replace damaged fasteners.	X	X	X
Verify wiring to all components is correct and be certain that all connections are tight.	X		X
Verify there is no exposed/bare wiring or terminals. Cover any exposures with terminal boots, heat shrink tubing or electricians tape.	X		X
Inspect rope for damage. Replace rope immediately if damaged.	X	X	X
Keep winch, rope and switch control free from contaminants. Use a clean rag or towel to remove any dirt and debris.		X	

WARNING To prevent serious injury or death:



Always spool the winch rope onto the drum as indicated by the drum rotation label.



Always Wind Rope on Bottom of Drum.
Never Wind Rope Over Top of Drum.

Once you have performed system check. Turn key switch to ON position and check winch for proper operation. The rope should spool in and out in the direction indicated on the switch.

