

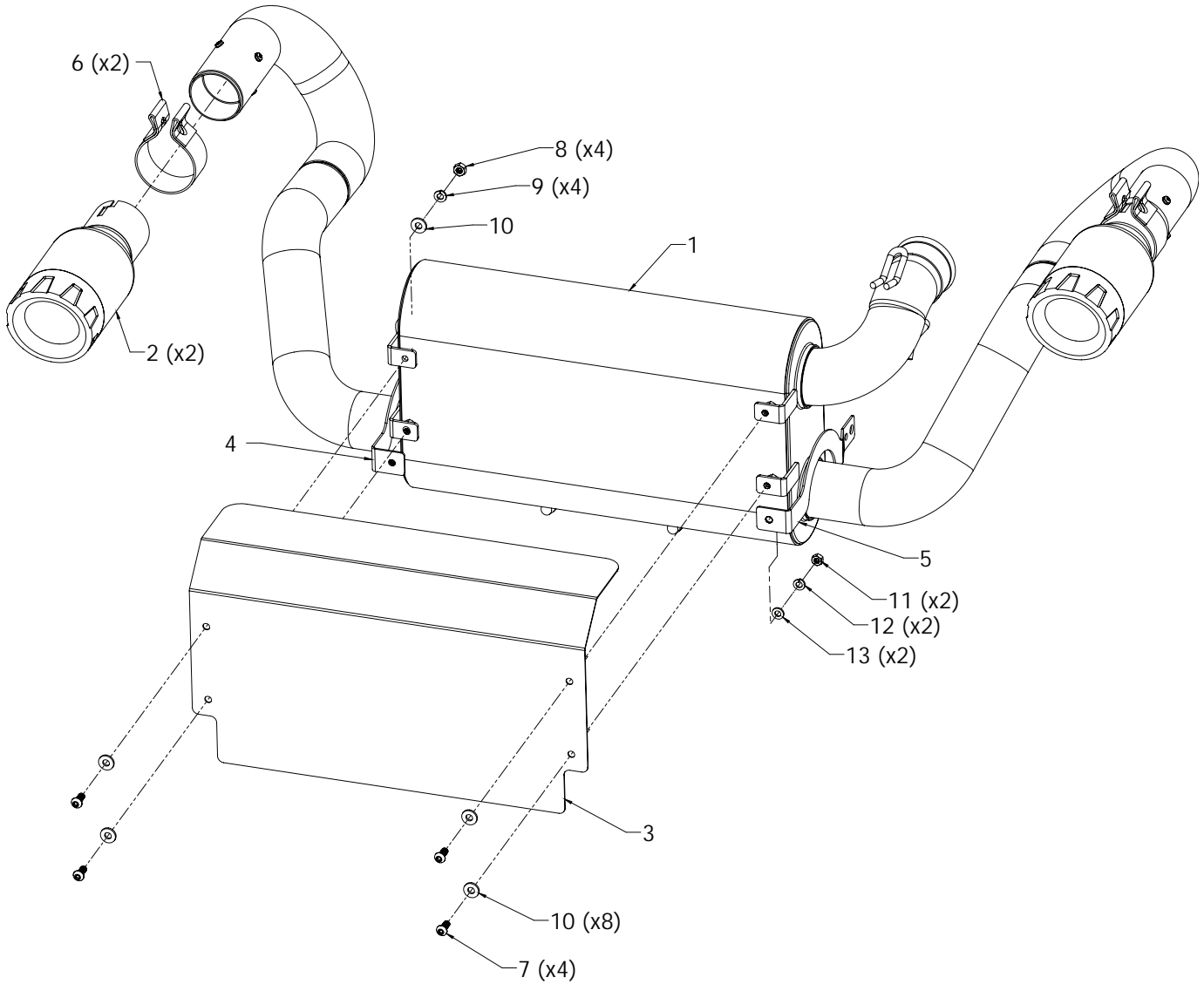

Installation Instructions for
7509
DUAL OUT XDR EXHAUST
2015-2018 POLARIS RZR S 900



ITEM	PART NO.	DESCRIPTION	QTY.
1	842583-529	Axle Back Muffler	1
2	ST473	Black End 3½" x 2¼" Exhaust Tip	2
3	HS128	Heatshield	1
N/A	PK982	Hardware Pack includes:	1
4	HA1825	Right Heatshield Standoff	1
5	HA1826	Left Heatshield Standoff	1
6	MC225BS	2¼" Stainless Band Clamp	2

ITEM	PART NO.	DESCRIPTION	QTY.
7	HW269	¼"-20 x ⅝" BTNHD Screw	4
8	HW124	¼" Hex Nut	4
9	HW332	¼" Split Lock Washer	4
10	HW333	¼" Flat Washer	8
11	HW127	M6 x 1 Hex Nut	2
12	HW337	M6 Split Lock Washer	2
13	HW338	M6 Flat Washer	2

OVERVIEW:

REQUIRED MATERIALS

- Penetrating oil (WD-40 or similar)
- Anti-seize compound (Permatex Nickel or similar)



1. Please take a moment to read and understand these instructions before installing your purchased performance kit. Use the parts drawing and list to verify kit contents.

WARNING:

Avoid serious burns! Allow vehicle time to cool completely before handling any of the stock engine components.

REMOVE STOCK EXHAUST COMPONENTS:



2. Remove factory screws (x12) securing rear fascia to UTV. Retain them for later use.



3. Slowly pull back rear fascia and unplug rear taillight harness.

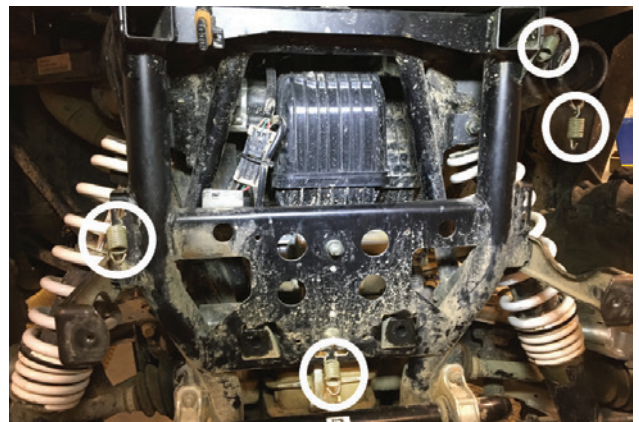

NOTE: We recommend using safety glasses and a spring removal tool to complete this step.

4. Remove tension springs (x4) securing muffler to vehicle. Retain springs for later use.



5. Remove muffler from vehicle.

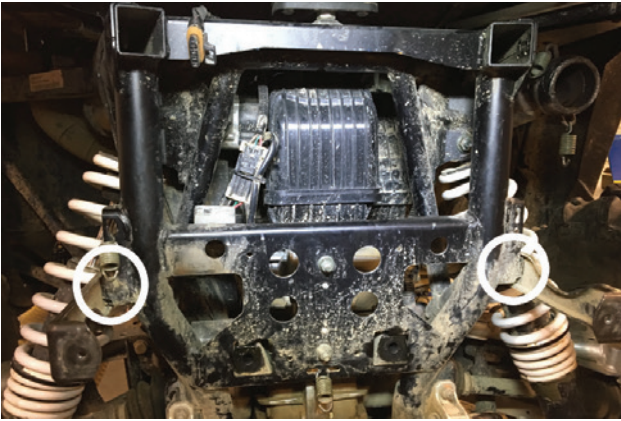

6. Unbolt factory rear panel support brackets and set aside bolts (x2) for later use.

Install your dual out XDR exhaust kit:

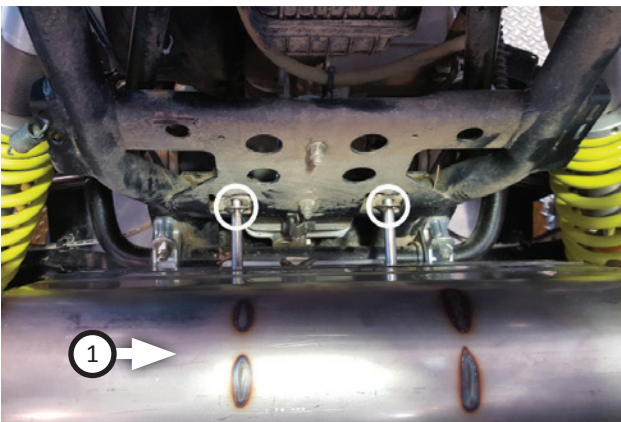

7. Set **muffler (1)** hanger rods into UTV muffler body then push muffler fully on.

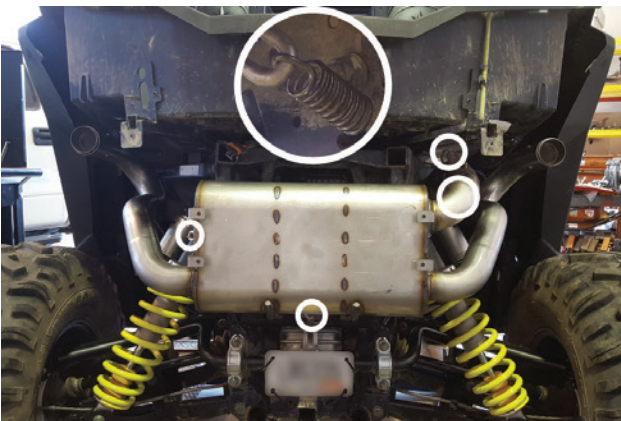

8. Secure muffler to frame by attaching tension springs (x4) (removed step 4).

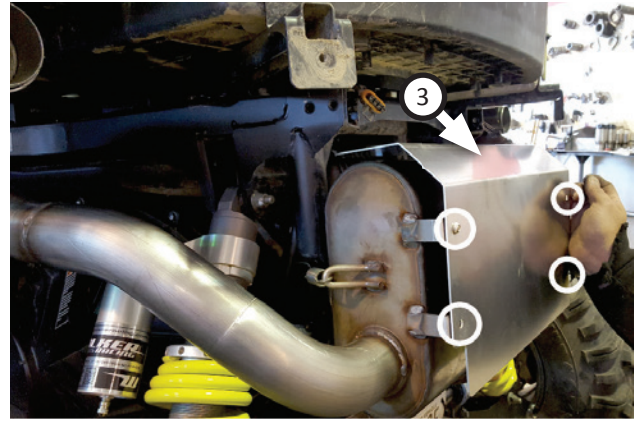

9. Attach **heatshield (3)** to muffler brackets using (x4 ea.) **screws (7)** through **flat washers (10)**, heatshield, brackets, **flat washers (10)**, **split lock washers (9)** and **hex nuts (8)**.

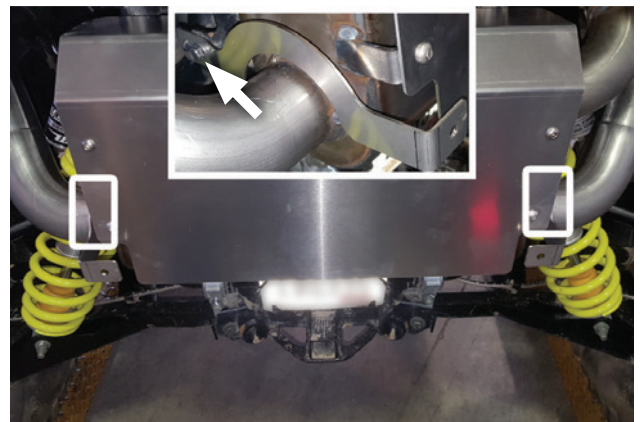

10. Install **right and left heatshield standoffs (4,5)** onto vehicle frame using bolts (x2) (removed step 6).



11. Install rear fascia using (x2 ea.) screws (removed step 2) through standoffs, **flat washers (13)**, **split lock washers (12)** and **hex nut (11)**.



12. Re-connect rear taillight harness as shown.



Congratulations, the installation of your XDR performance exhaust kit is now complete!

SHOP MORE XDR PRODUCTS:



13. Place (x2 ea.) clamps (6) onto exhaust tips (2) then connect them to tailpipes. Tighten clamps to secure connection.



XDR is a Powersports division resulting from a joint effort by B&M Racing and Flowmaster to provide customers with the ultimate in off-road performance. To access a full range of XDR SXS/UTV products (like those pictured below) visit the website listed at the bottom of the page.



14. Install remaining screws (x10) (removed step 2) to complete fascia install.

NOTE: XDR Offroad Group maintains a highly trained technical service department to answer your technical questions, provide additional product information and offer various recommendations.

